

CUSTOMER DRAWING

REV.	DESCRIPTION	APPROVED BY	DATE	ECN NO.
B	新增料號		17/10/14"	
C	新增料號		14/01/15"	
D	MODIFY DIM.	Yeh Chou	04/03/20"	

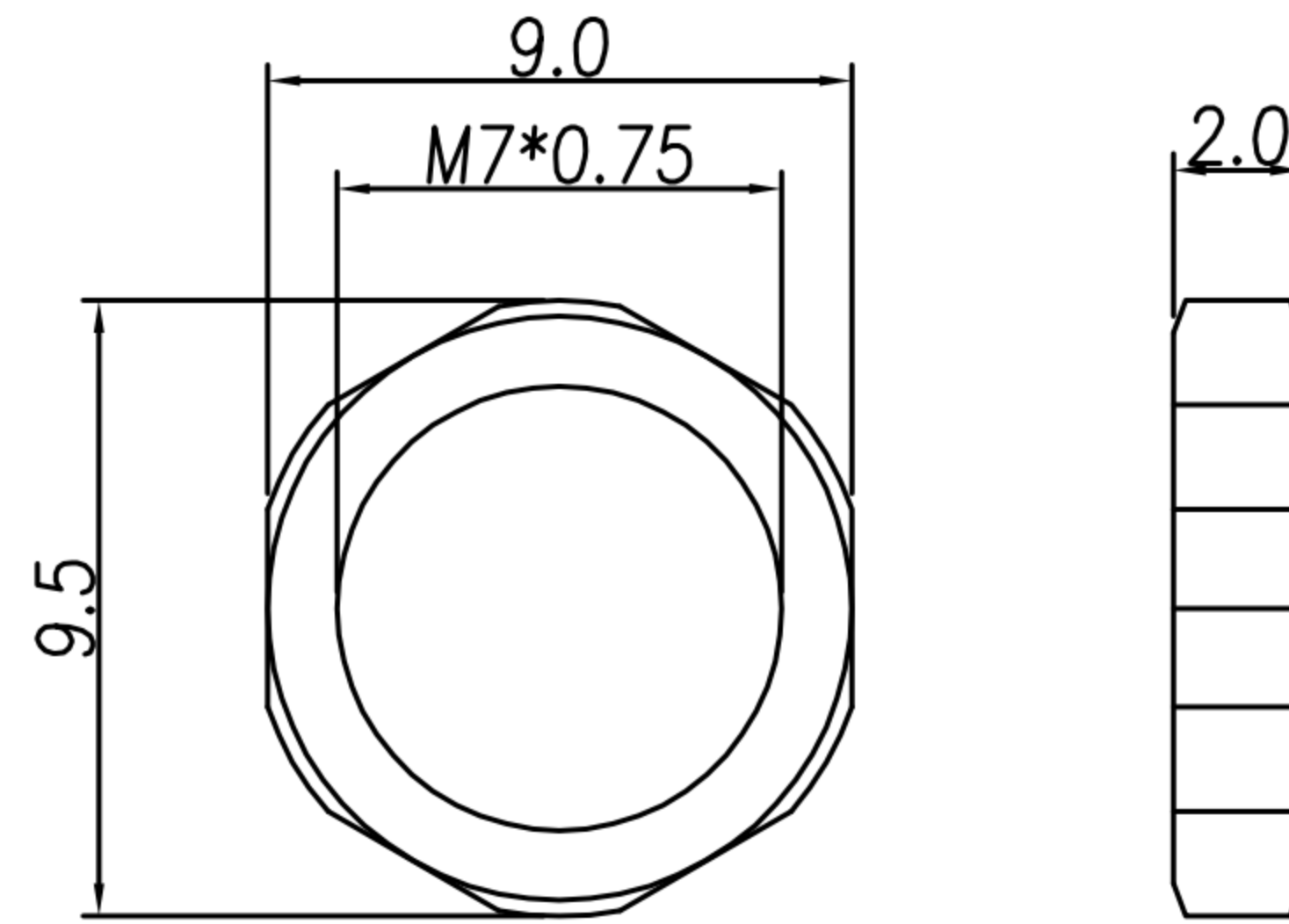

NUT

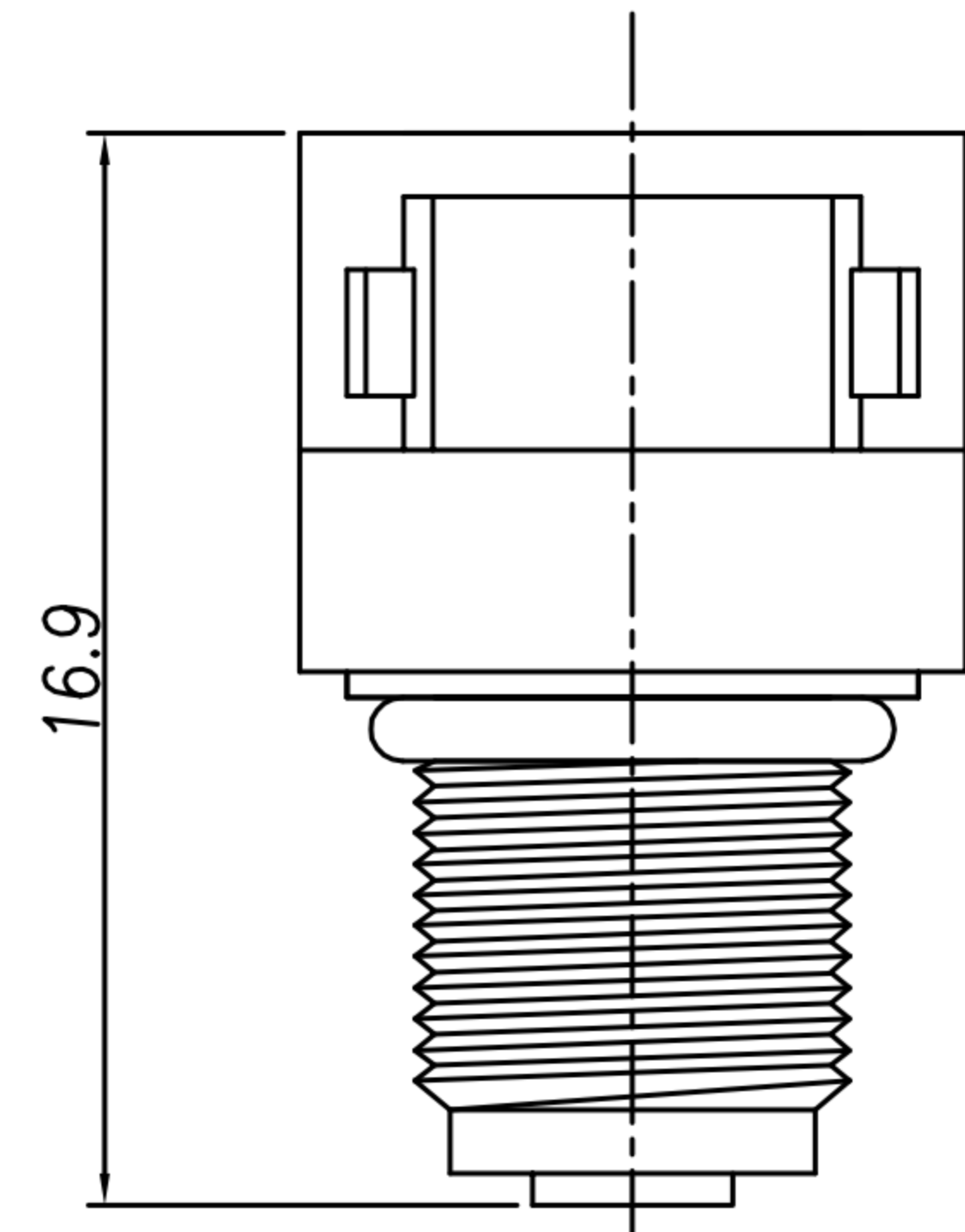
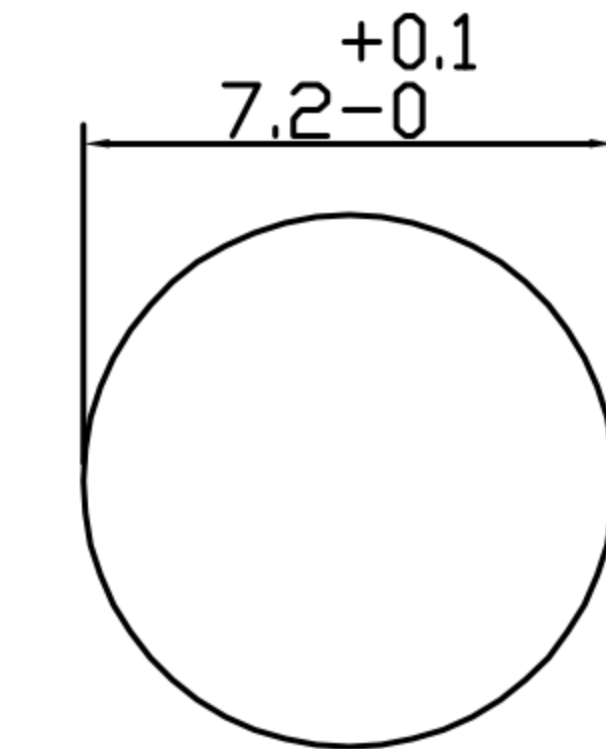
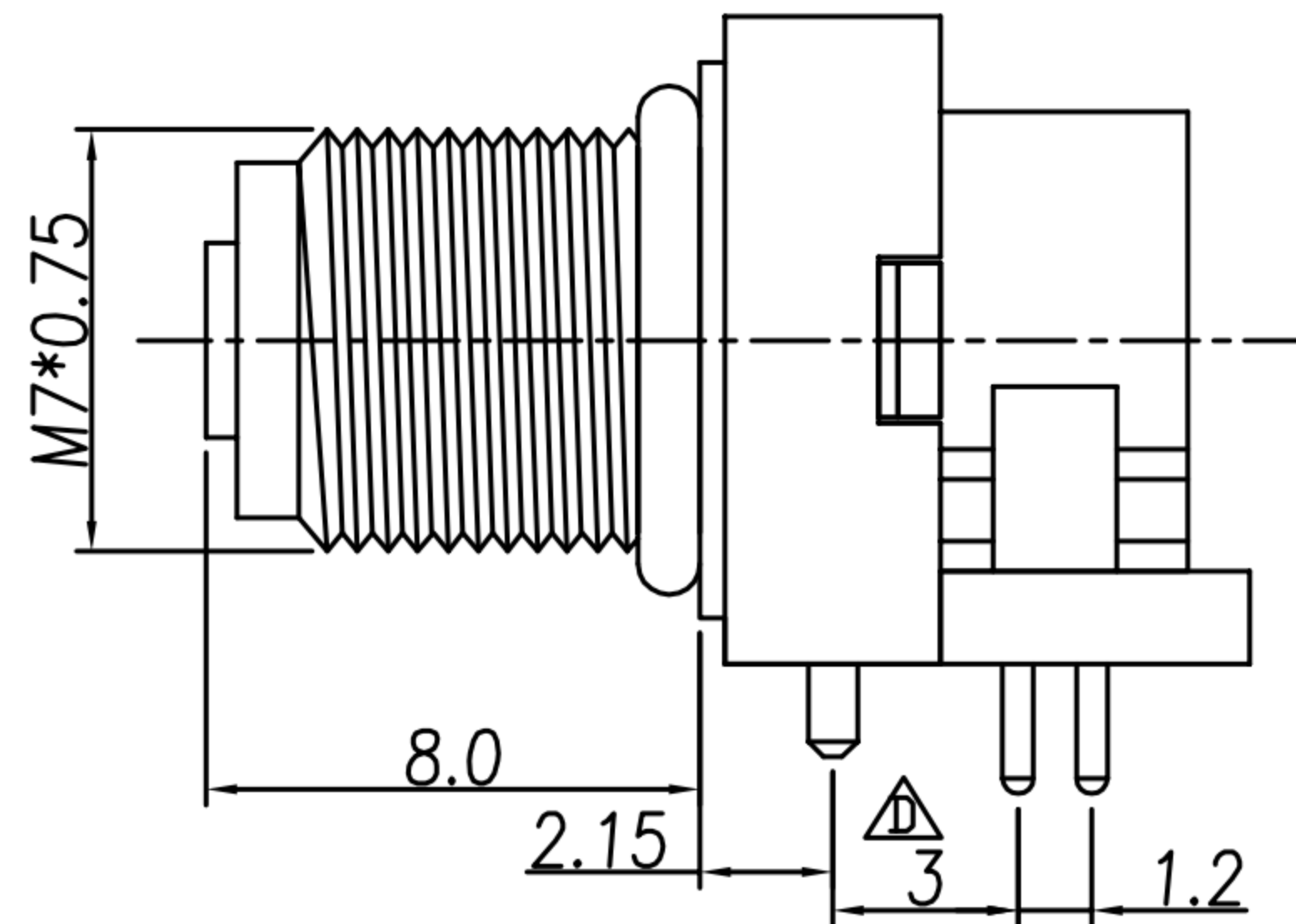
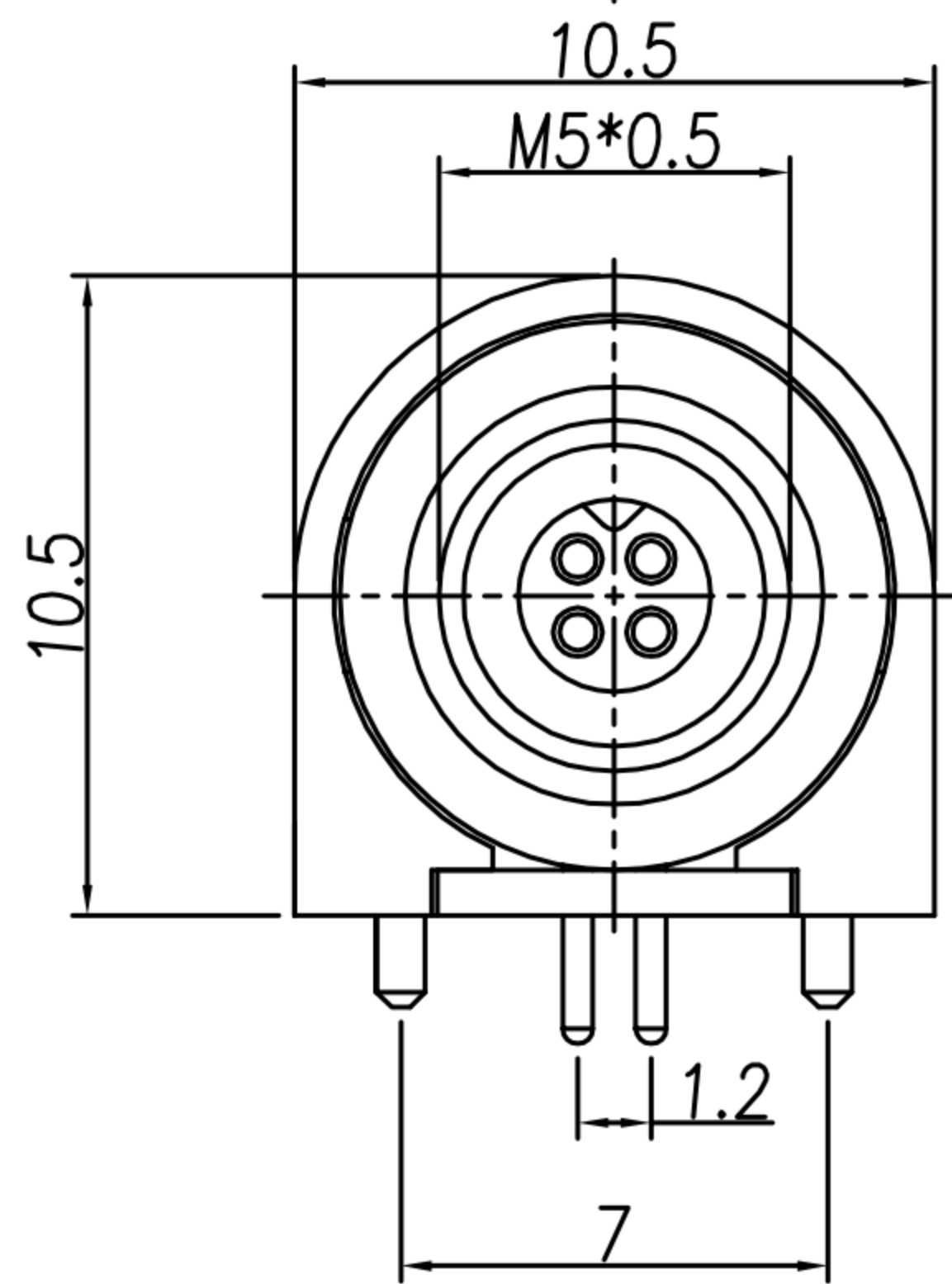

PANEL CUT-OUT

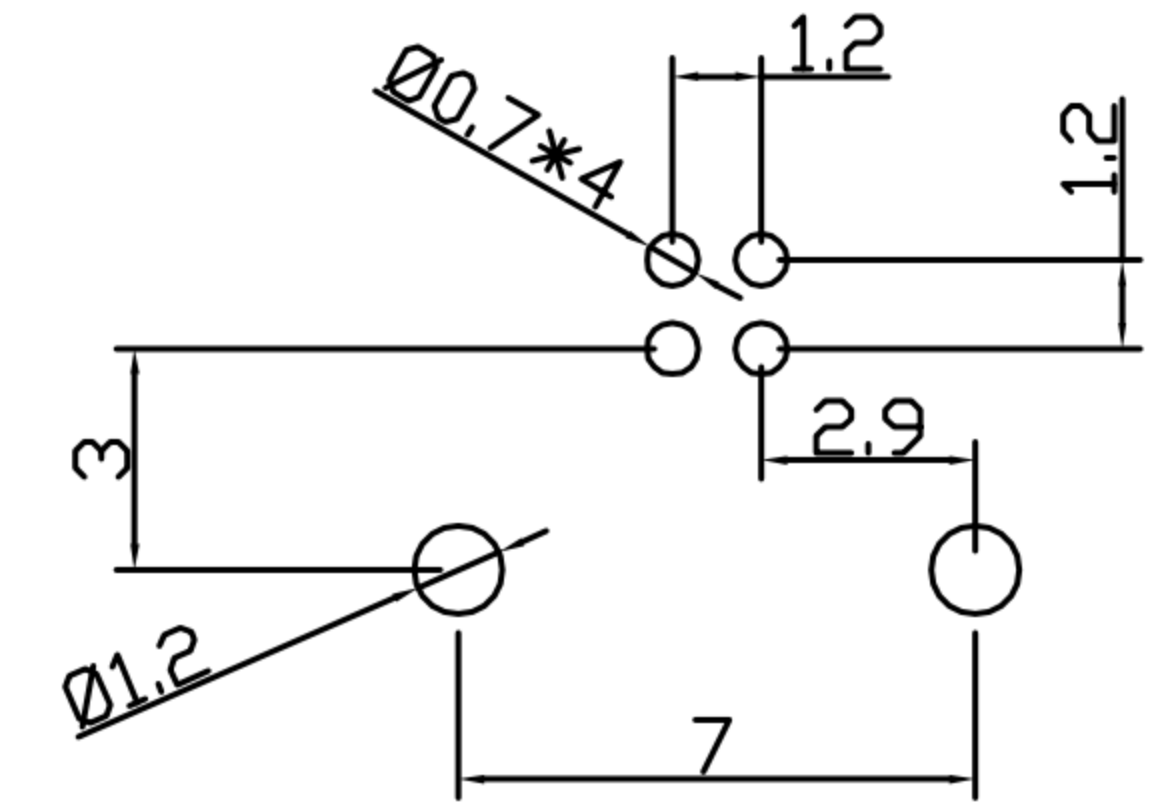

P.C.B LAYOUT

NOTE:

- MATERIAL :
  - 1-1. HOUSING : PBT UL94V-0 ; COLOR : BLACK
  - 1-2. CONTACT : BRASS
  - 1-3. NUT : BRASS
  - 1-4. SHELL : BRASS
  - 1-5. O-RING : NBR ; COLOR : BLACK
  - 1-6. BACK HOUSING : PBT UL94V-0 ; COLOR : BLACK
  - 1-7. DOWN HOUSING : PBT UL94V-0 ; COLOR : BLACK
- FINISH :
  - 2-1. CONTACT : SEE TABLE A
  - 2-2. NUT : SEE TABLE A" ON OVER ALL
  - 2-3. SHELL : SATIN NICKEL PLATED
- ELECTRICAL SPECIFICATION :
  - 3-1. Rated current : 1A
  - 3-2. Rated voltage : 60V
  - 3-3. Water proof: IP67
- Environmental :
  - 4-1. Operation Temperature : -20℃~85℃

TABLE A

WP-04F2-147-11	SATIN NICKEL 80u"~100u"	GOLD 10u"
WP-03F2-68-11	SATIN NICKEL 80u"~100u"	GOLD 10u"
WP-02F2-44-11	SATIN NICKEL 80u"~100u"	GOLD 10u"
WP-04F2-63	SATIN NICKEL 80u"~100u"	GOLD FLASH
WP-03F2-51-11	SATIN NICKEL 80u"~100u"	GOLD FLASH
WP-02F2-34-11	SATIN NICKEL 80u"~100u"	GOLD FLASH
WP-04F2-119-11	BLACK Cr	GOLD FLASH
PART NO	NUT	FINISH

TABLE A

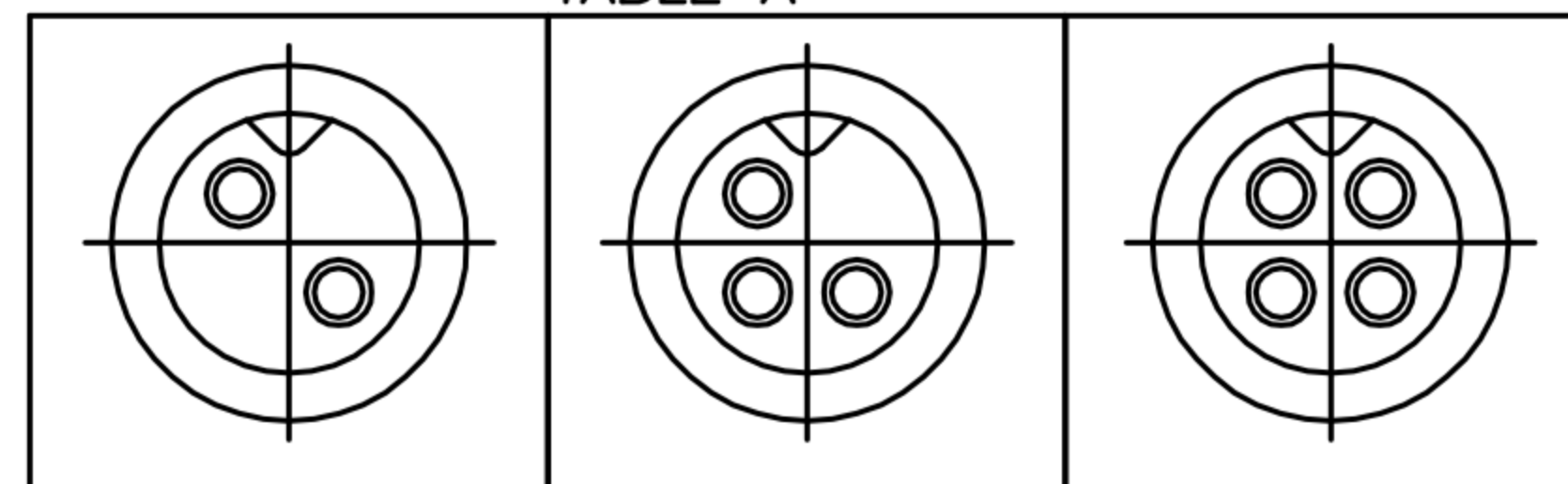

DRAWN	Yeh Chou	APPEND	Ku Chou	UNIT	mm	TOLERANCE			广东科斯达电子科技有限公司 GUANG DONG KE SI DA ELECTRONIC TECHNOLOGY CO., LTD.	TITLE	M5*0.5 (F) 90度板端			SHEET	1
CHK'D	Emily Suen			SCALE	1:1					PART NO.	SEE TABLE A	DWG NO.	QC5220	VERSION	D