

CUSTOMER DRAWING

REV.	DESCRIPTION	APPROVED BY	DATE	ECN NO.
A				
B				
C				

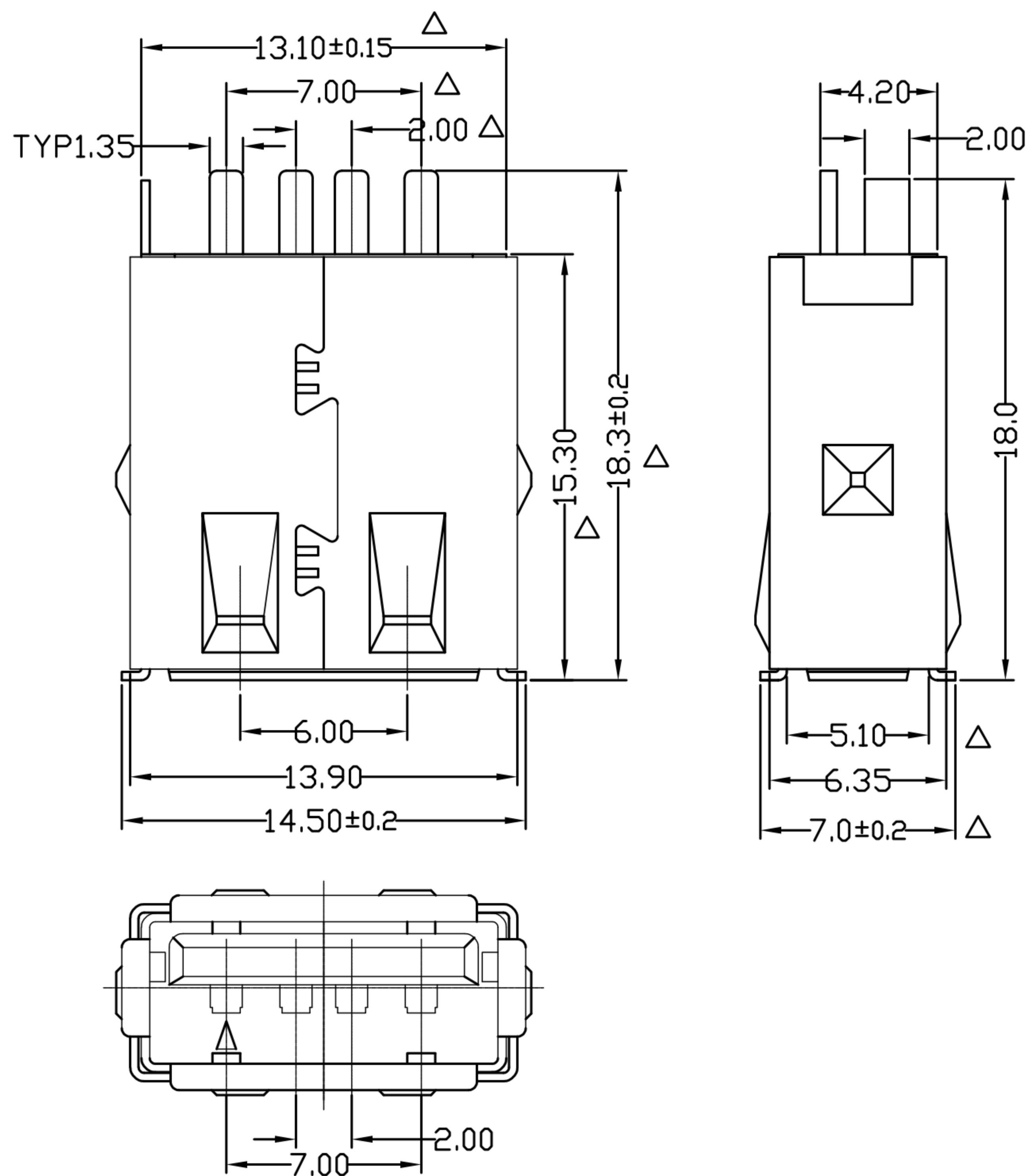

Note:

1. Material:

- 1.1 Insulator: PBT UL94-V0 ; COLOR : WHITE
- 1.2 Contact: PHOSPHOR BRONZR
- 1.3 Shell: SPCC

2. Specification:

- 2.1 Contact resistance: 30 mΩ Max
- 2.2 Insulation resistance: 1000 MΩ Min
- 2.3 Dielectnic voltage: 500V AC one sec level
- 2.4 Operating temperature: -55°C ~ -105°C
- 2.5 Total mating force: 3.5 Kgf Max.
- 2.6 Total unmating force: 1.0 Kgf Min.
- 2.7 Major DIM: Δ

3. Finishes:

- 3.1 Contacts: SELECT Gold flashed
- 3.2 Shell: Nickel plated.

DRAWN	Mark Kao	APP'D	Ku Chou	UNIT	MM	TOLERANCE		广东科斯达电子科技有限公司 GUANG DONG KE SI DA ELECTRONIC TECHNOLOGY CO., LTD.	TITLE	USB A TYPE SOLDER 4PIN(F)+馬口鐵外套			SHEET
CHK'D	Emily Suen			SCALE	3:1	.x ±0.20 .xx ±0.10 .xxx ±0.05 .xxxx ±0.03 ANGULA ±1°			PART NO.	US-04F1-08	DWG NO.	QC3102	VERSION