

CUSTOMER DRAWING

REV.	DESCRIPTION	APPROVED BY	DATE	ECN NO.
△A	RELEASE	Emily Suen	30/12/11'	
△B	CHANGE CONTACT FINISH	Ku Chou	30/05/19'	ECN-19006
△C	CHANGE MATERIAL	Ku Chou	16/09/22'	

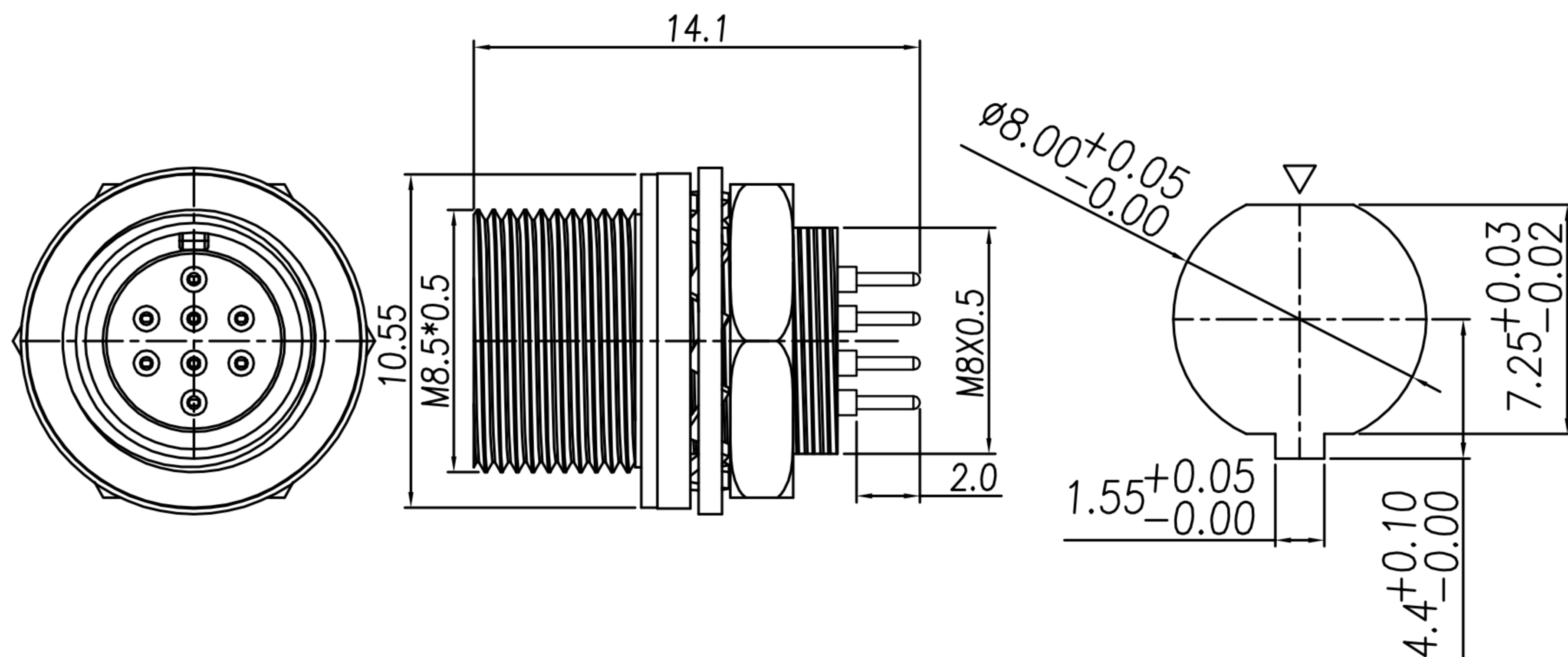

- MATERIAL :**
 - △C 1-1. HOUSING : NYLON 66 ; COLOR : BLACK
 - 1-2. CONTACT : BRASS
 - 1-3. SHELL : Zinc Alloy
 - 1-4. O-RING : EPDM; COLOR : BLACK
 - 1-5. NUT : BRASS
 - 1-6. WASHER : BRASS
- FINISH :**
 - 2-1. CONTACT : 10u" MIN. GOLD PLATED △B
 - UNDER PLATE : NICKEL
 - 2-2. SHELL : NICKEL PLATED .
 - 2-3. NUT : NICKEL PLATED.
- ELECTRICAL SPECIFICATION :**
 - 3-1. Rated current : 1A
 - 3-2. Rated voltage : 30V AC , 42V DC
- Environmental :**
 - 4-1. Operation Temperature : -25℃~85℃

RECOMMEND PANEL CUT-OUT

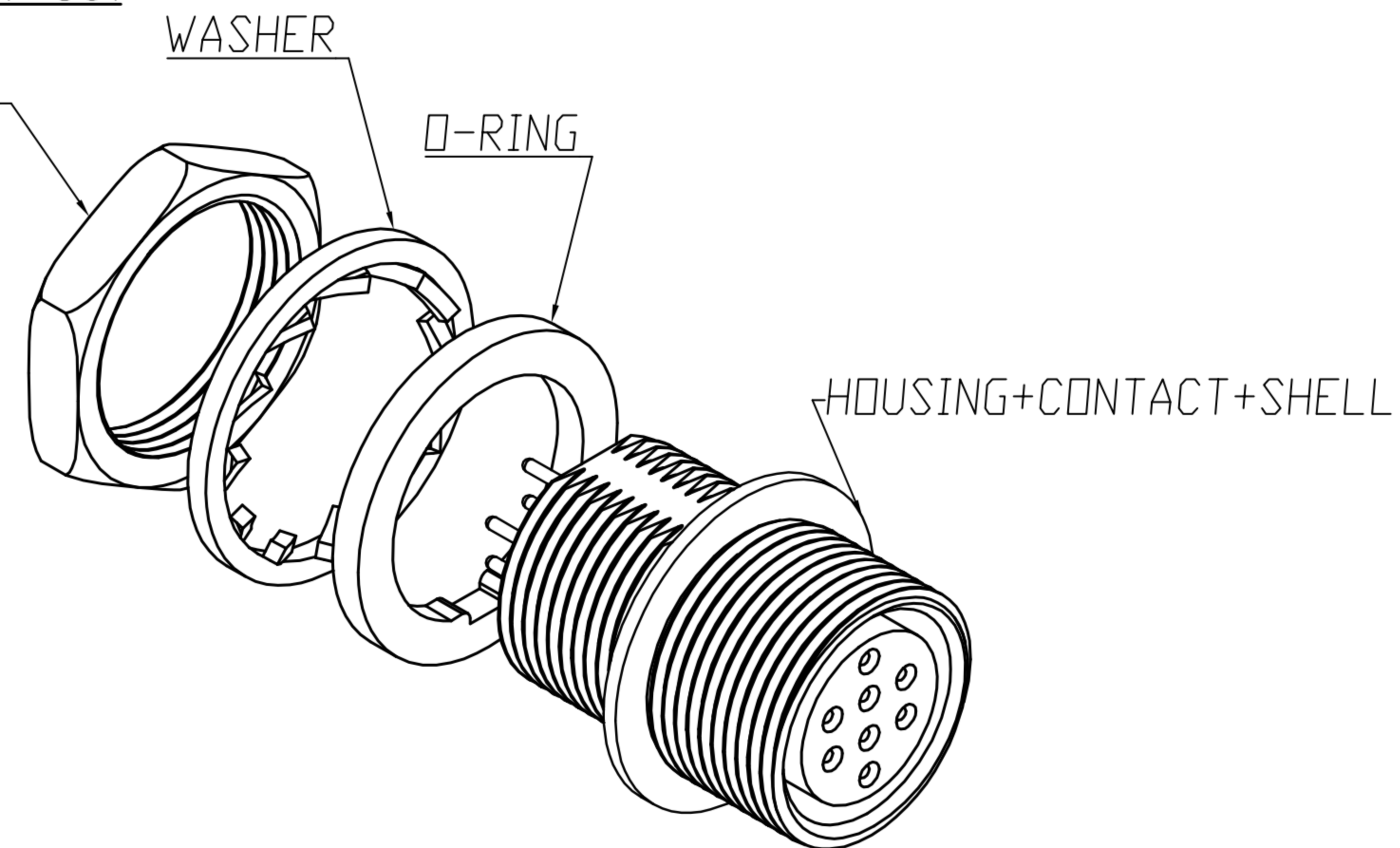
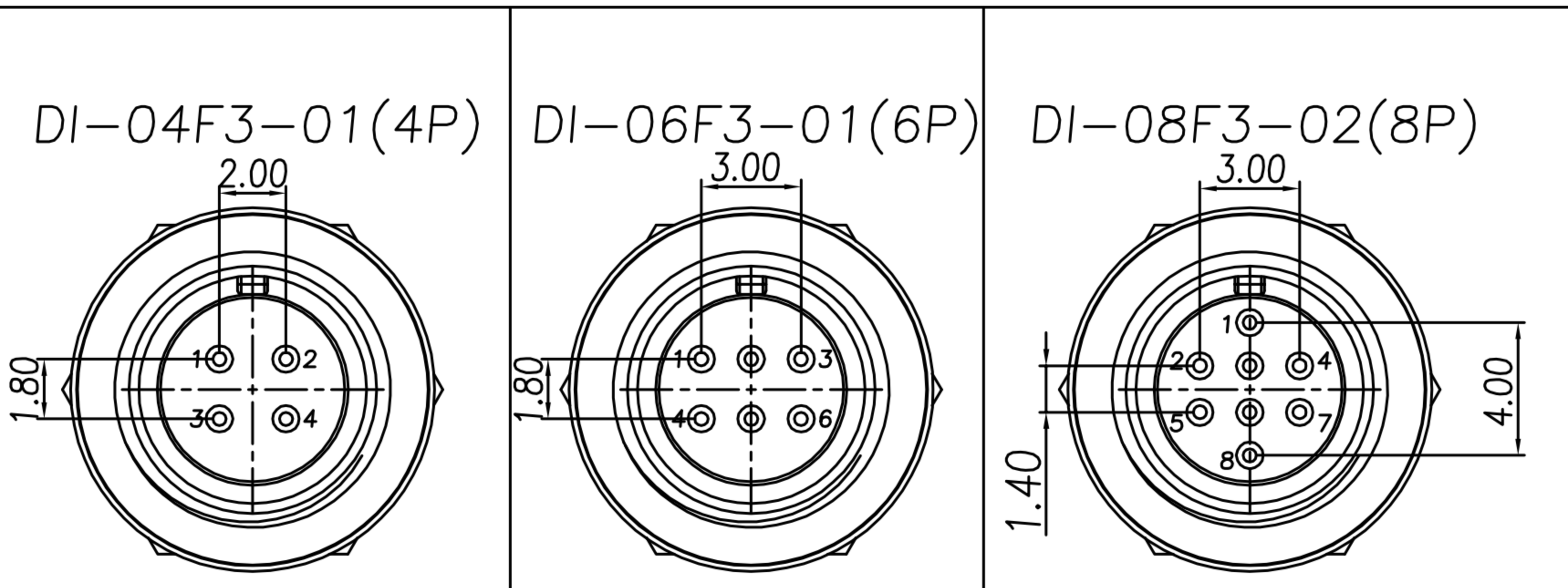

DRAWN	Mark Kao	APPEND	Ku Chou	UNIT	mm	TOLERANCE			TITLE	DIN M8*0.5 (F) 连接器(SHELL:RECEPTACLE)			SHEET	1/2
CHKED	Emily Suen			SCALE	1:1	ANGULA			±1°	PART NO.	SEE TABLE	DWG NO.	QC5638	VERSION

广东科斯达电子科技有限公司
GUANG DONG KE SI DA ELECTRONIC TECHNOLOGY CO., LTD.