

CUSTOMER DRAWING

REV.	DESCRIPTION	APPROVED BY	DATE	ECN NO.
A	RELEASE	Fido Weng	22/12/08'	
B	CHANGE FINISH SPEC.	Fido Weng	18/05/09'	ECN09079
C				

步驟一:

1. 將成品一一放入包裝盤內, 依同一方向置入.
2. 包裝方式, 如圖所示.
3. 一個包裝盤內放 1200 pcs.

步驟二:

1. 一個紙箱可以裝 6 個包裝盤.
2. 每盤 1200 pcs, 每箱 7200 pcs.
3. 將包裝盤放入防水袋中, 包裝完後再封箱.

步驟三:

1. 用膠帶將紙箱封實.
2. 將標籤貼於紙箱上.

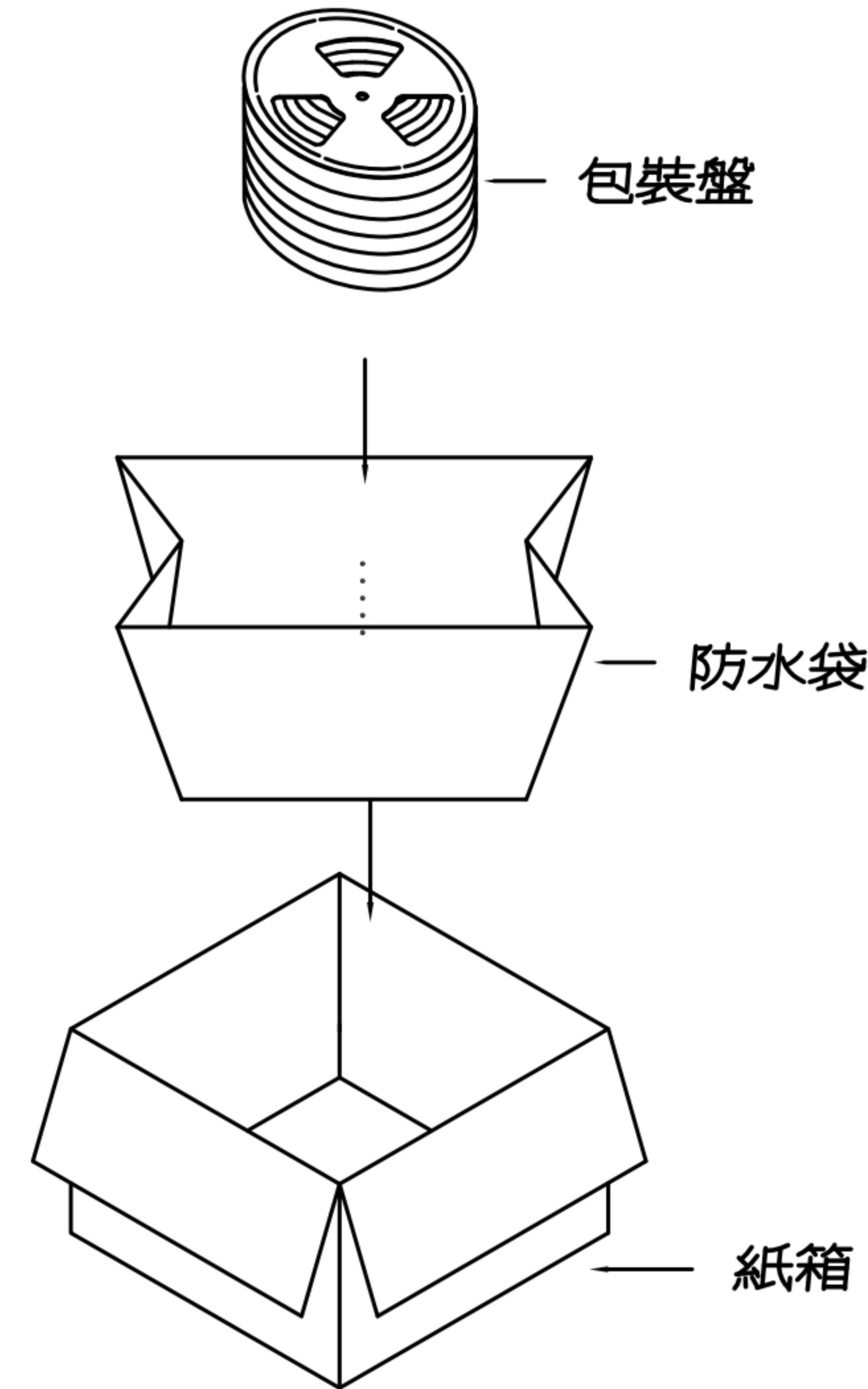
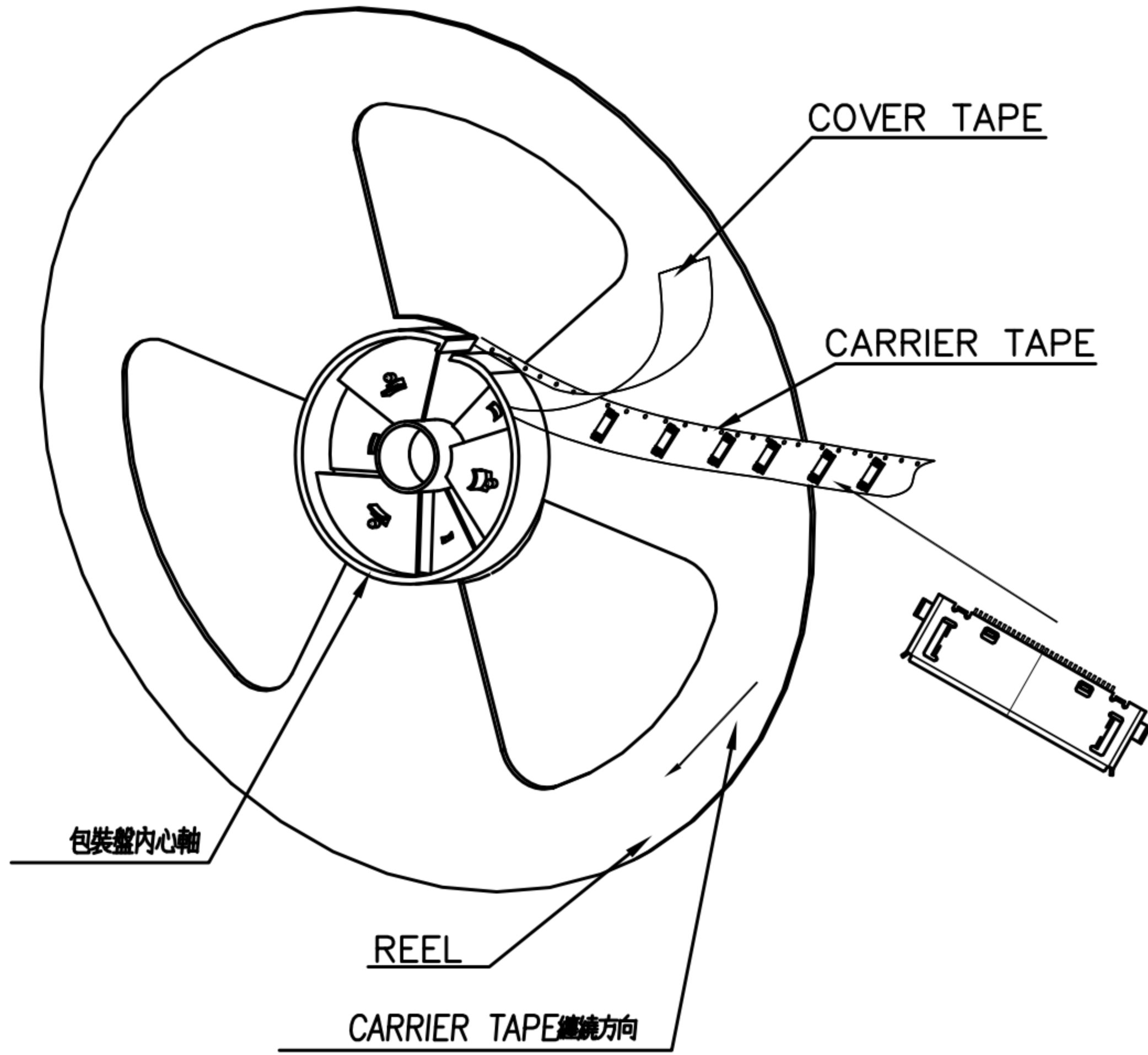

ITEM NO:
 QTY: PGS
 N. W. : KG
 G. W. : KG
 MEAS:

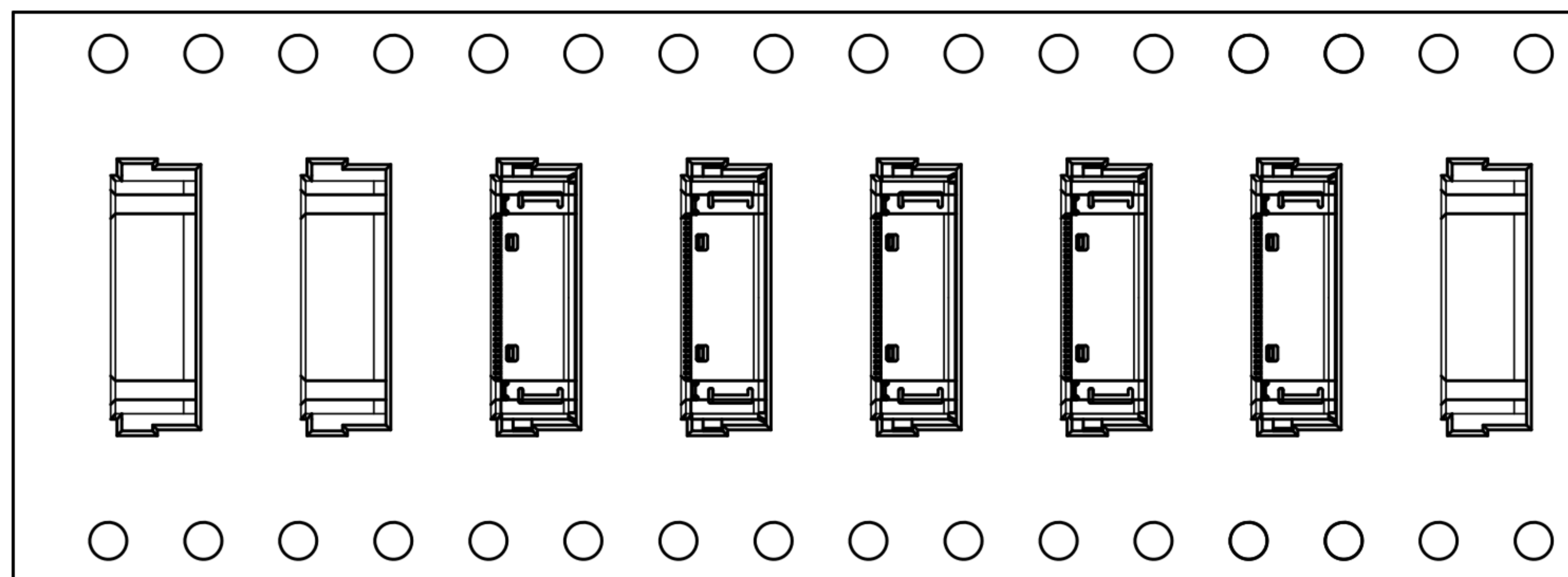
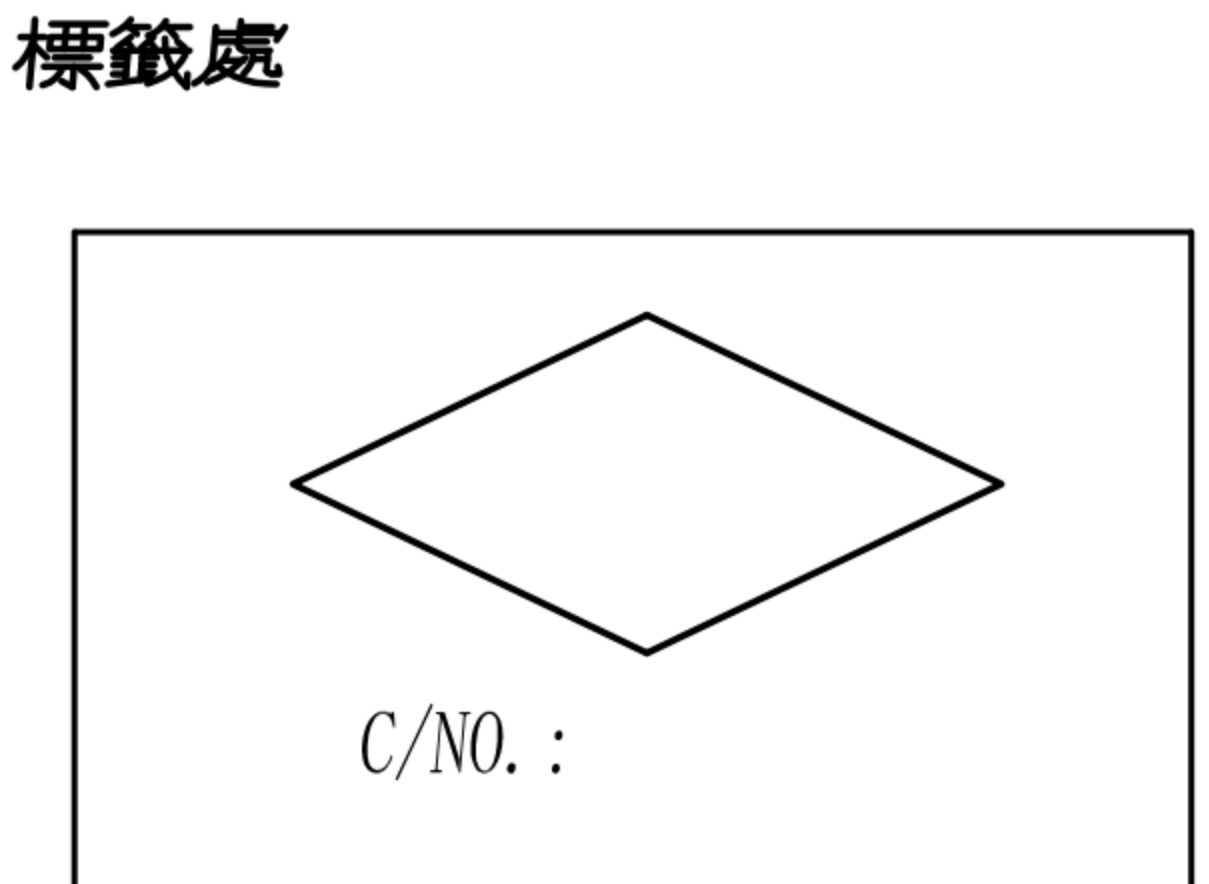

NOTE:

1. 若有未裝滿之零數箱, 必須以緩衝材塞滿.
2. 在搬運過程中要輕拿輕放.
3. 載運輸中不可堆放過多, 不可有重壓現象.
4. 在裝滿後, 必須空留帶前和帶後 15 格以上, 然後用紙膠布貼上.
5. 上帶在貼下帶時必須平整, 且黏貼處不要出現氣泡.

DRAWN	Yeh Chou	APP'D	Fido Weng	UNIT	mm	TOLERANCE		广东科斯达电子科技有限公司 GUANG DONG KE SI DA ELECTRONIC TECHNOLOGY CO., LTD.	TITLE	IPOD 30PIN (F) CONN			SHEET	2/2
CHK'D	Emily Suen			SCALE	1:1	.x ±0.20 .xx ±0.10 .xxx ±0.05 .xxxx ±0.03 ANGULA ±1°			PART NO.	TABLE A	DWG NO.	QC2157	VERSION	B

CUSTOMER DRAWING

REV.	DESCRIPTION	APPROVED BY	DATE	ECN NO.
△A	RELEASE	Fido Weng	22/12/08'	
△B	CHANGE FINISH SPEC.	Fido Weng	18/05/09'	ECN09079
△C				

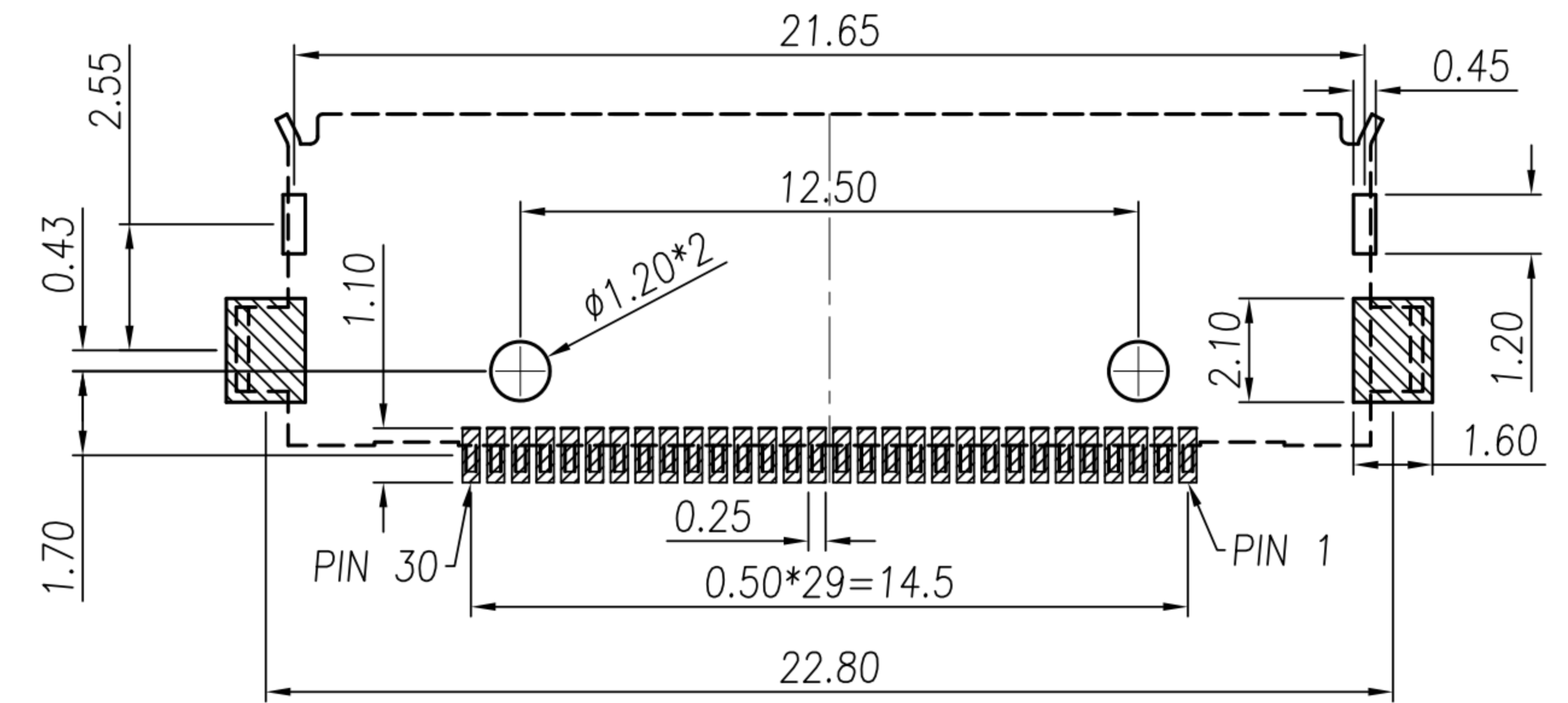
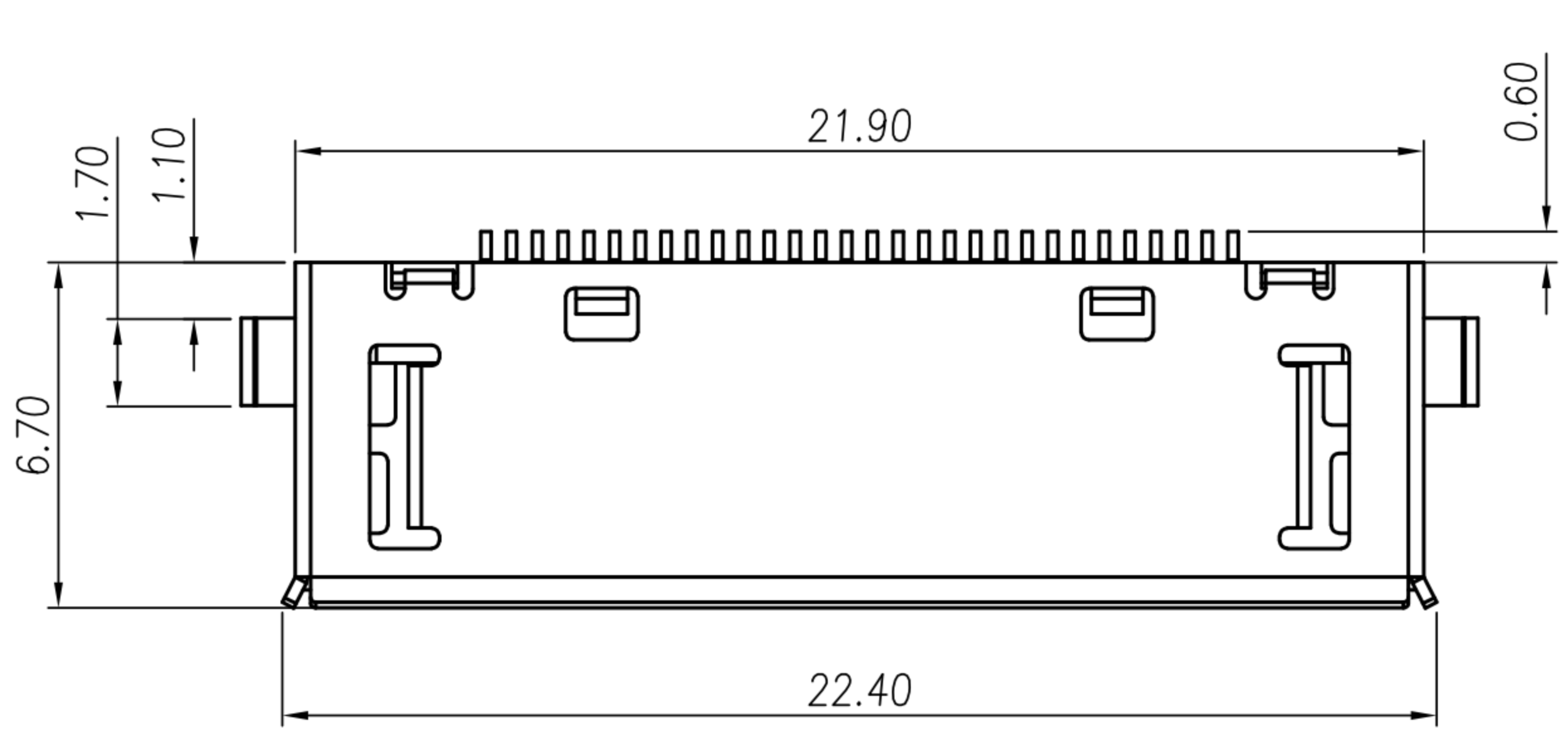

Recommend P.C.B Layout.

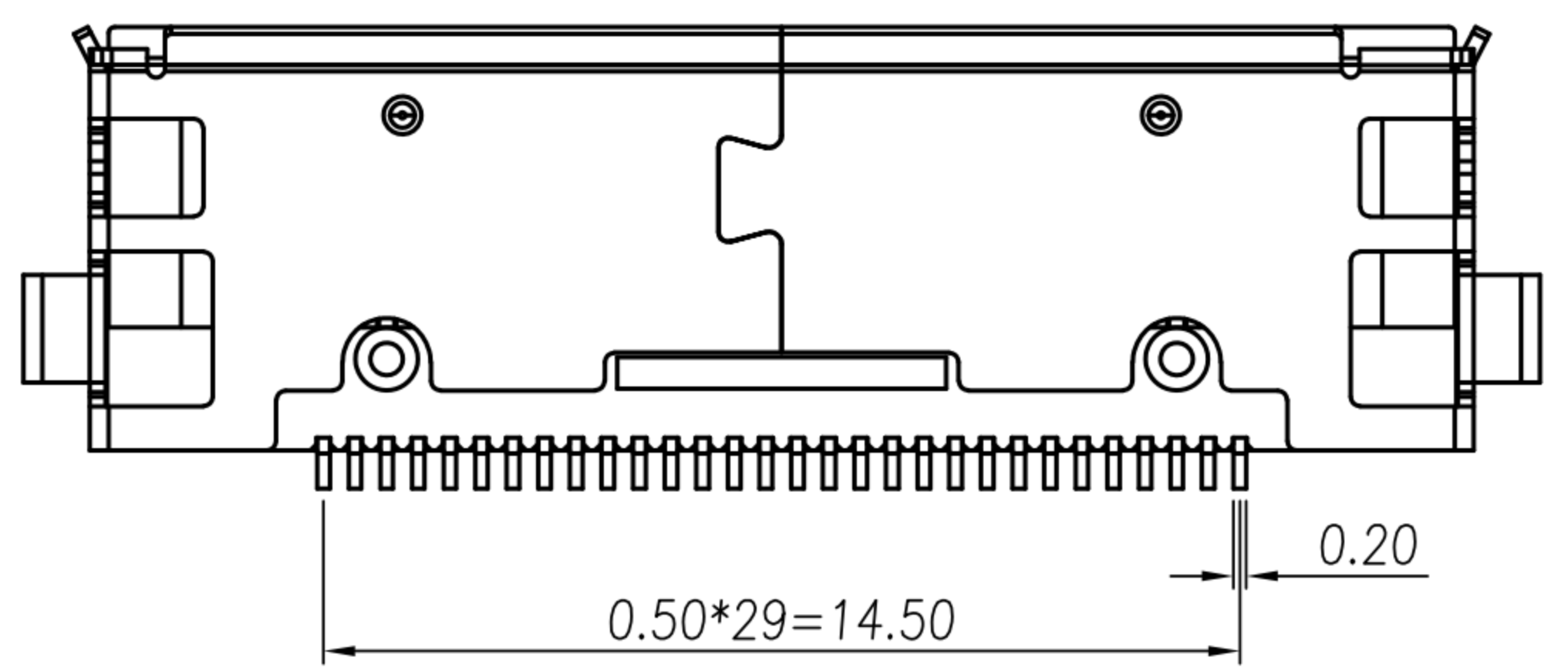
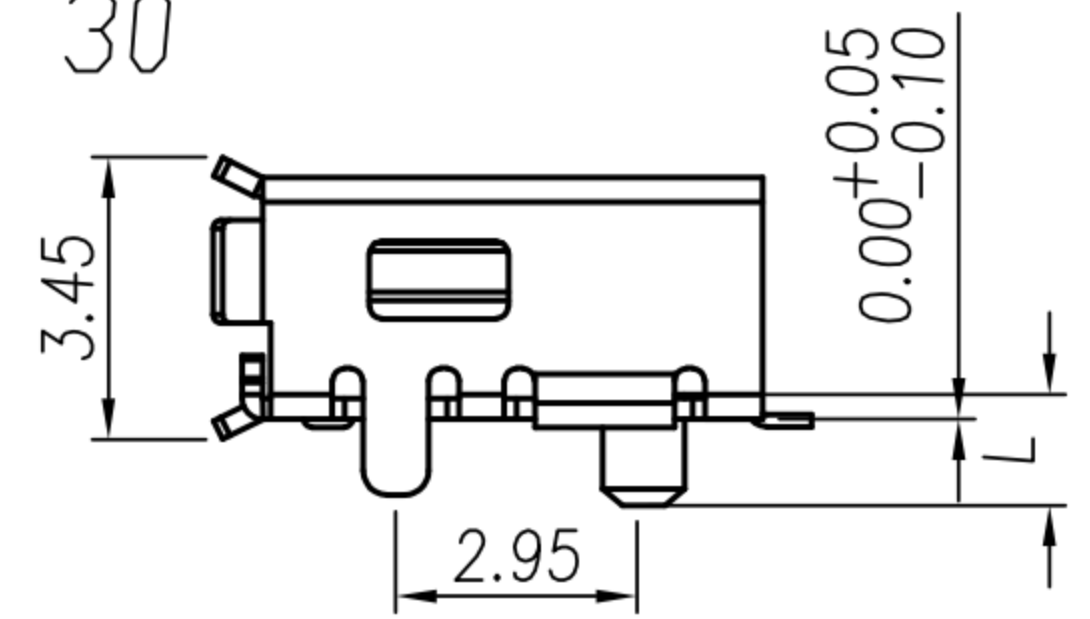
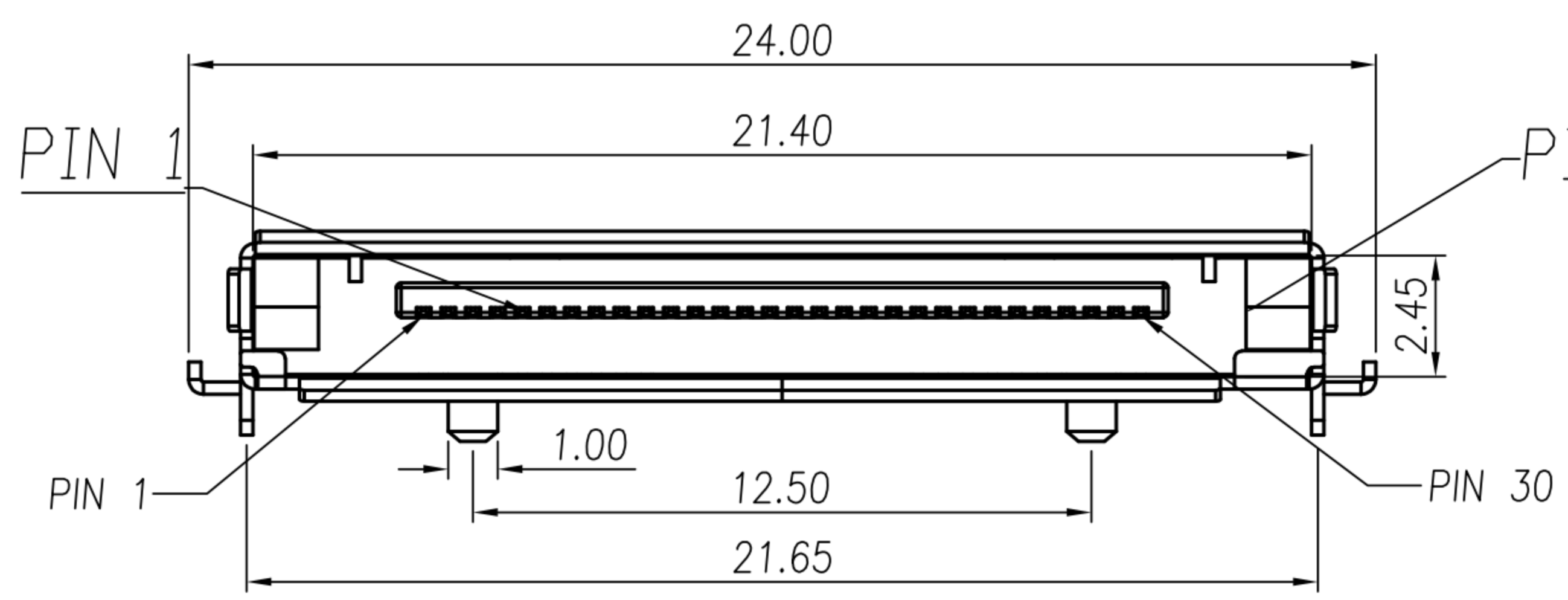

TABLE A

PC-30F4-04	iPOD 30PIN (F) 短POST 白色	WHITE	0.95
PC-30F4-03	iPOD 30PIN (F) 短POST 黑色	BLACK	0.95
PC-30F4-02	iPOD 30PIN (F) 白色	WHITE	1.35
PC-30F4-01	iPOD 30PIN (F) 黑色	BLACK	1.35
P/N	DESCRIPTION	HOUSING	L

- MATERIAL :
 - 1-1. HOUSING : LCP UL94V-0 ; COLOR : BLACK
 - 1-2. CONTACT : BRONZE
 - 1-3. SHELL : STAINLESS STEEL
- FINISH :
 - 2-1. CONTACT :
 - CONTACT AREA : 5 MICRO INCHES MIN. GOLD PLATED
 - SOLDER AREA : MATTE TIN 80u"
 - UNDER PLATE : NICKEL
 - 2-2. SHELL : MATTE TIN 25u" OVER ALL

DRAWN	Yeh Chou	APP'D	Fido Weng	UNIT	mm	TOLERANCE		广东科斯达电子科技有限公司 GUANG DONG KE SI DA ELECTRONIC TECHNOLOGY CO., LTD.	TITLE	iPOD 30PIN (F) CONN			SHEET	1/2
CHK'D	Emily Suen			SCALE	1:1	.x ±0.20 .xx ±0.10 .xxx ±0.05 .xxxx ±0.03 ANGULA ±1°			PART NO.	TABLE A	DWG NO.	QC2157	VERSION	B