

# CUSTOMER DRAWING

REV.	DESCRIPTION	APPROVED BY	DATE	ECN NO.
A	RELEASE	Fido Weng	04/03/10'	
B	CHANGE CONTACT PLATED	Ku Chou	10/06/19	ECN-19006
C				

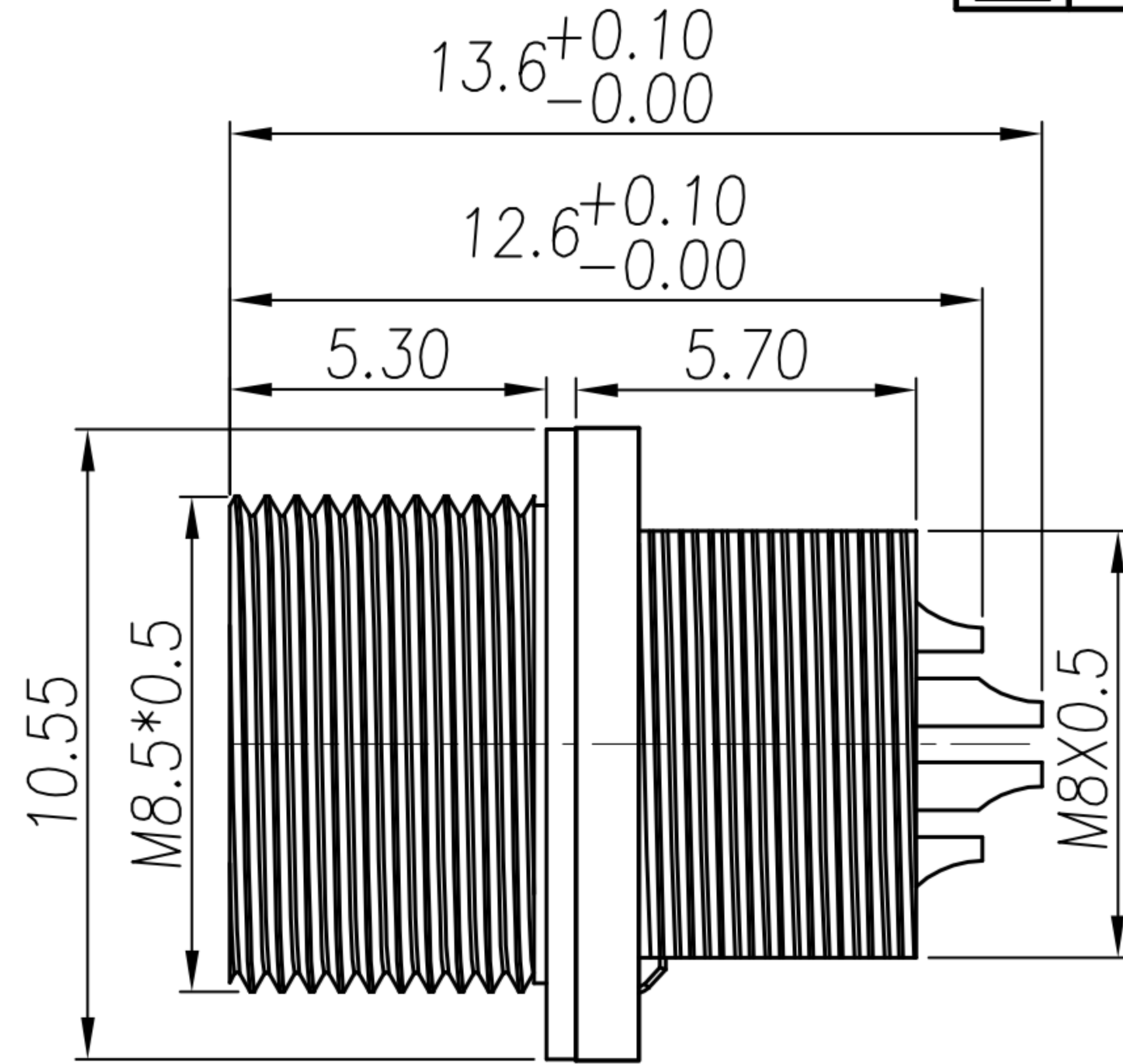

HOUSING+CONTACT+SHELL+O-RING

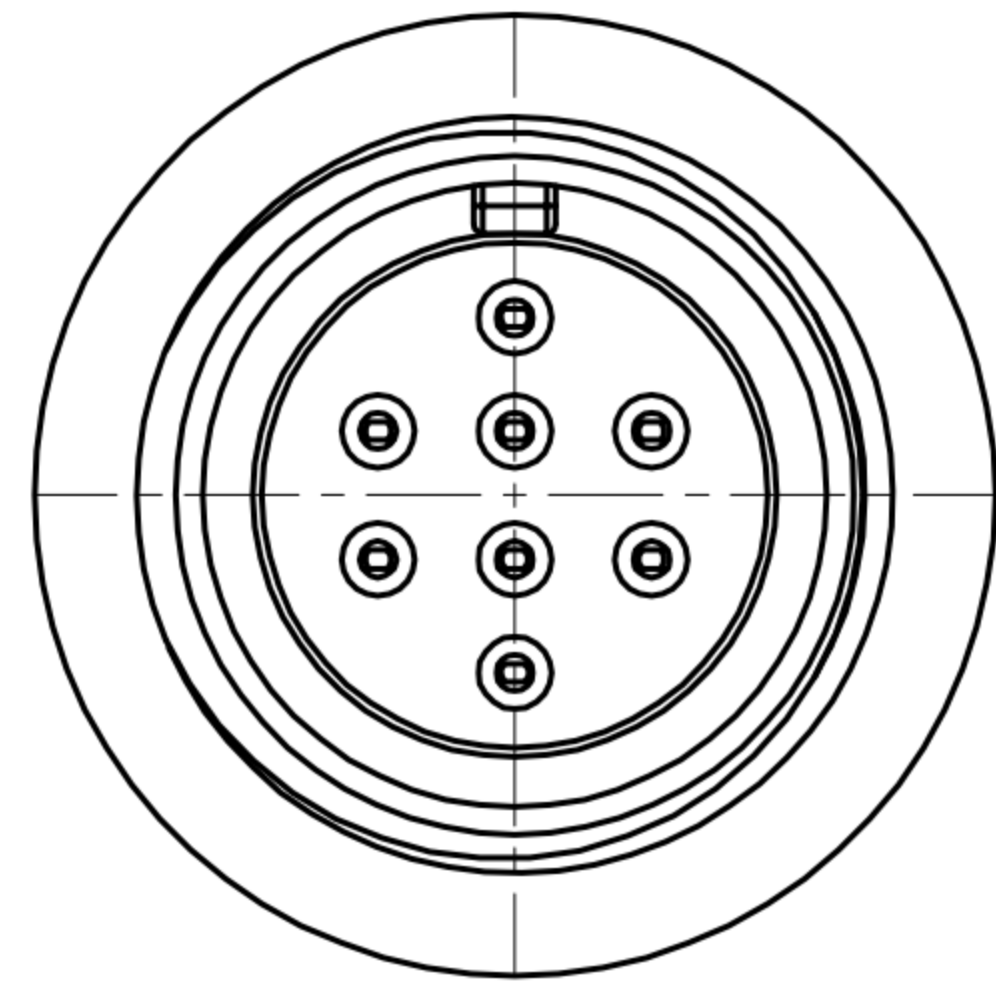
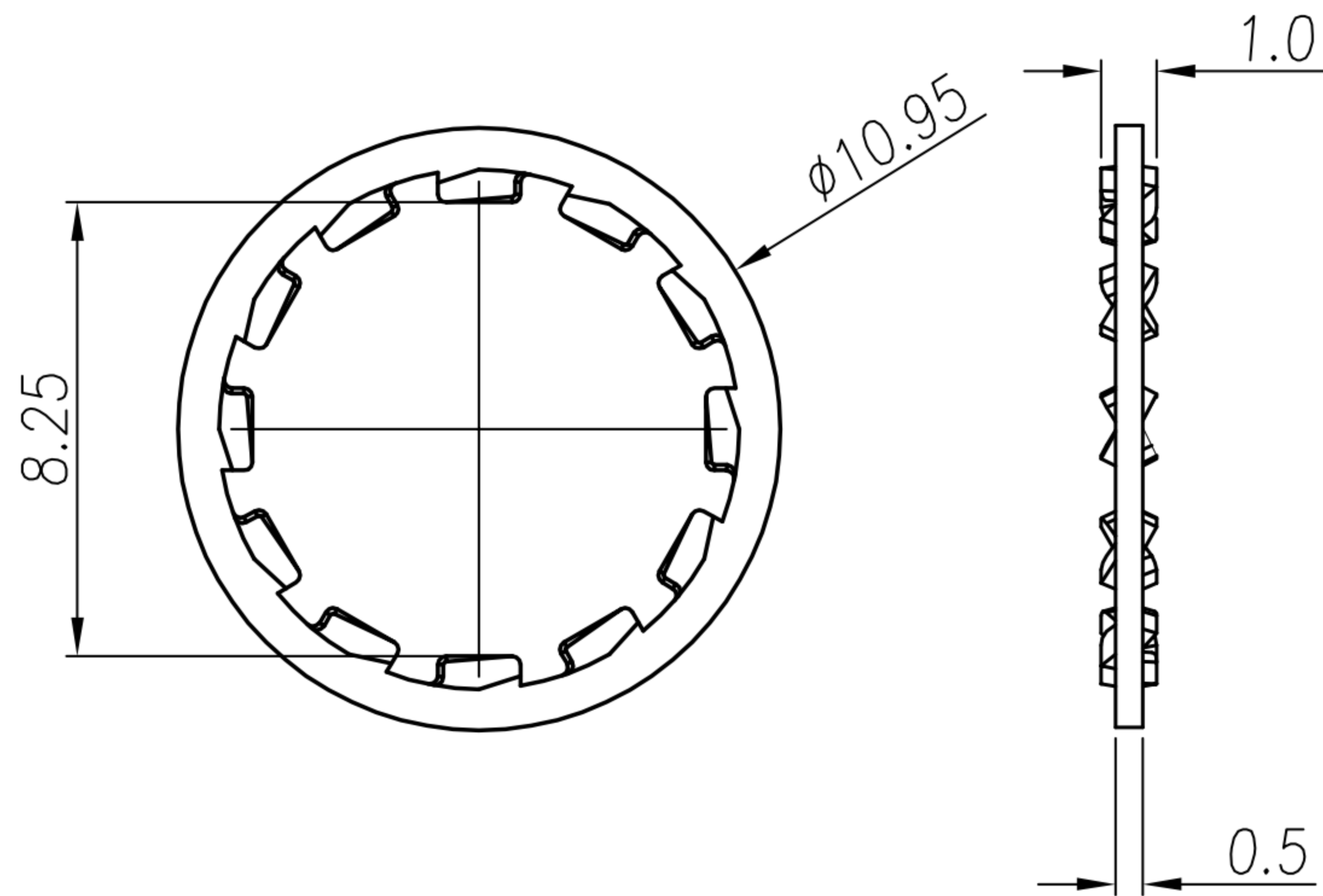

WASHER

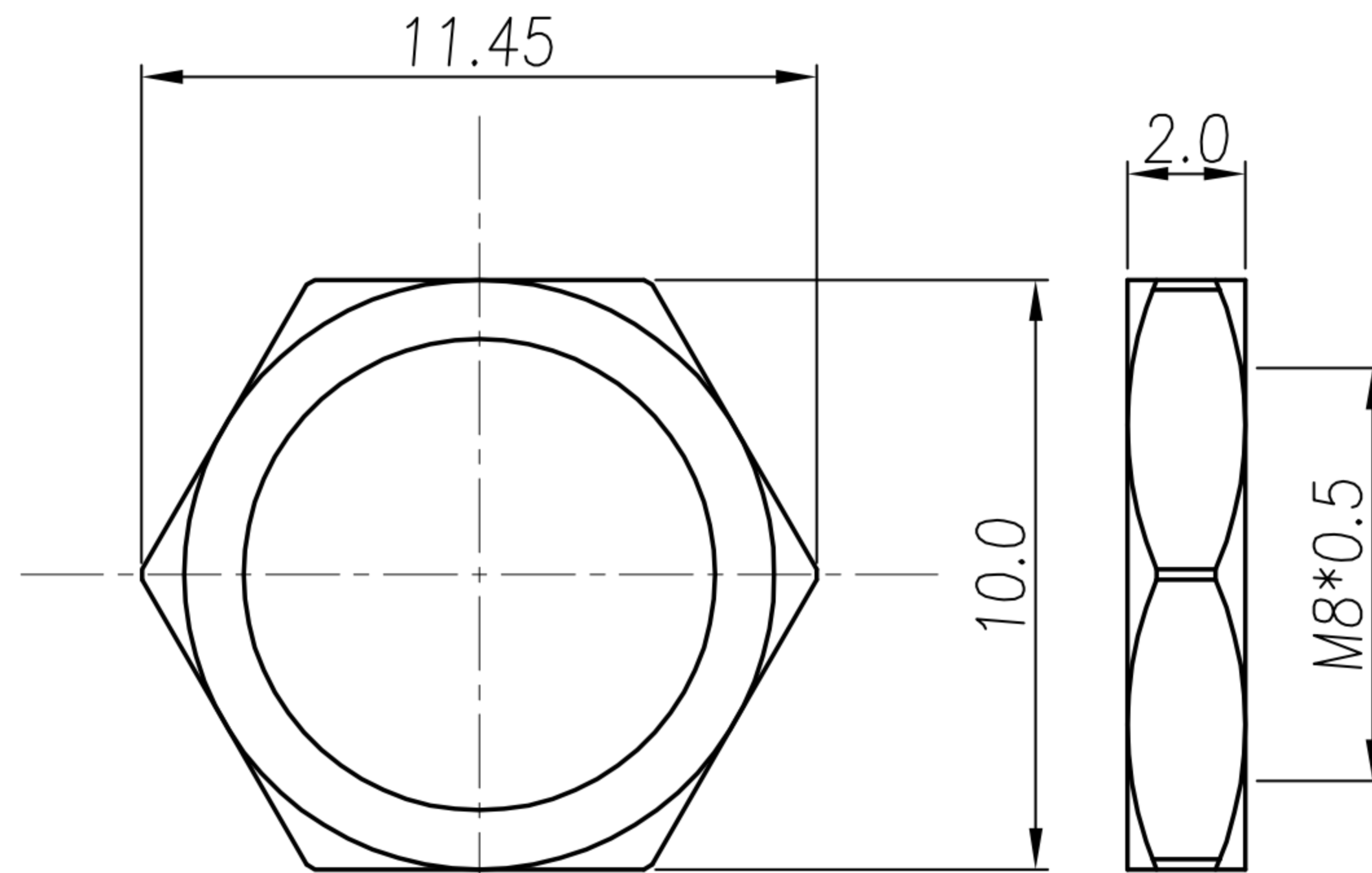

NUT

DRAWN	Jen Xie	APPEND	Emily Suen	UNIT	mm	TOLERANCE		广东科斯达电子科技有限公司 GUANG DONG KE SI DA ELECTRONIC TECHNOLOGY CO., LTD.	TITLE	防水頭 M8*0.5 (F) 銅板			SHEET	2
CHKD	Emily Suen			SCALE	1:1	.x ±0.20 .xx ±0.10 .xxx ±0.05 .xxxx ±0.03 ANGULA ±1°			PART NO.	SEE TABLE A	DWG NO.	QC5174	VERSION	B

# CUSTOMER DRAWING

REV.	DESCRIPTION	APPROVED BY	DATE	ECN NO.
△A	RELEASE	Fido Weng	04/03/10'	
△B	CHANGE CONTACT PLATED	Ku Chou	10/06/19	ECN-19006
△C	CHANGE MATERIAL	Ku Chou	16/09/22'	

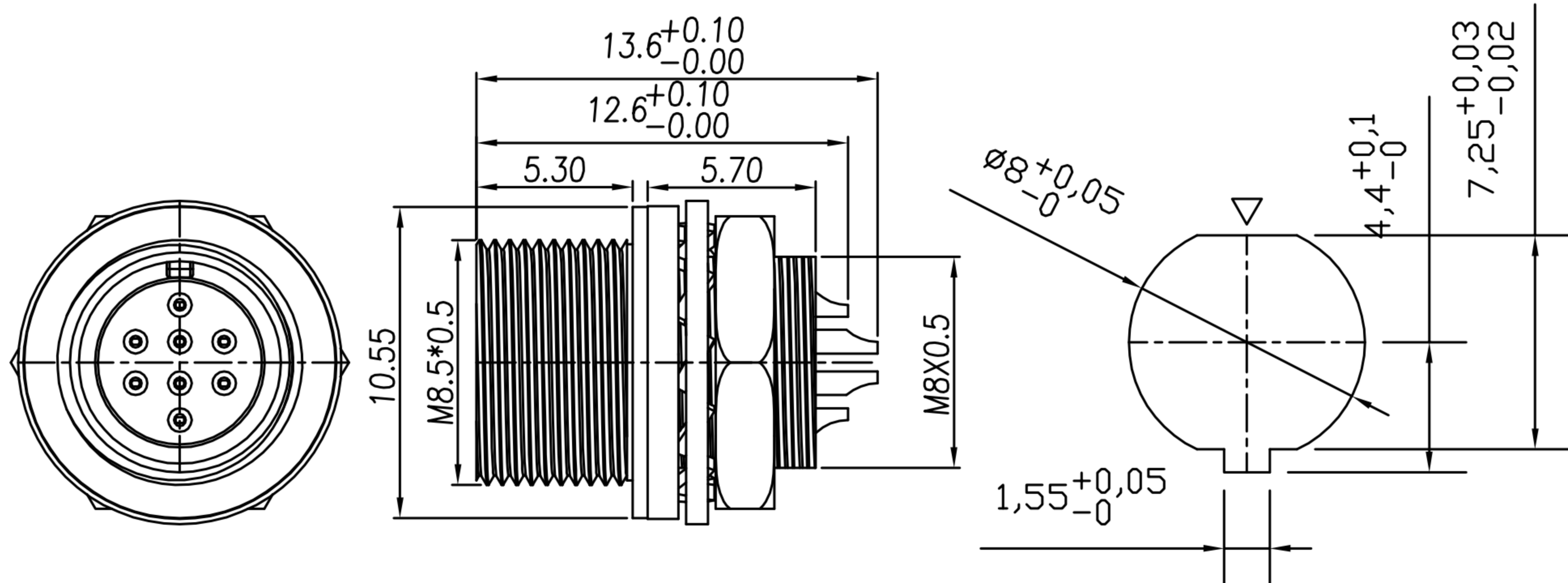

RECOMMEND PANEL CUT-OUT

- MATERIAL :
  - △ 1-1. HOUSING : NYLON 66 ; COLOR : BLACK
  - 1-2. CONTACT : PHOSPHOR BRONZE
  - 1-3. SHELL : Zinc Alloy
  - 1-4. NUT : BRASS
  - 1-5. O-RING : EPDM; COLOR : BLACK
  - 1-6. WASHER : BRASS
- FINISH :
  - 2-1. CONTACT : GOLD 10u" △
  - UNDER PLATE : NICKEL
  - 2-2. SHELL : NICKEL PLATED .
  - 2-3. NUT : NICKEL PLATED.
- ELECTRICAL SPECIFICATION :
  - 3-1. Rated current : 1A
  - 3-2. Rated voltage : 30V AC , 42V DC
- Environmental :
  - 4-1. Operation Temperature : -25℃~85℃

TABLE A

DI-04F2-02(4P)	DI-06F2-03(6P)	DI-08F2-02(8P)

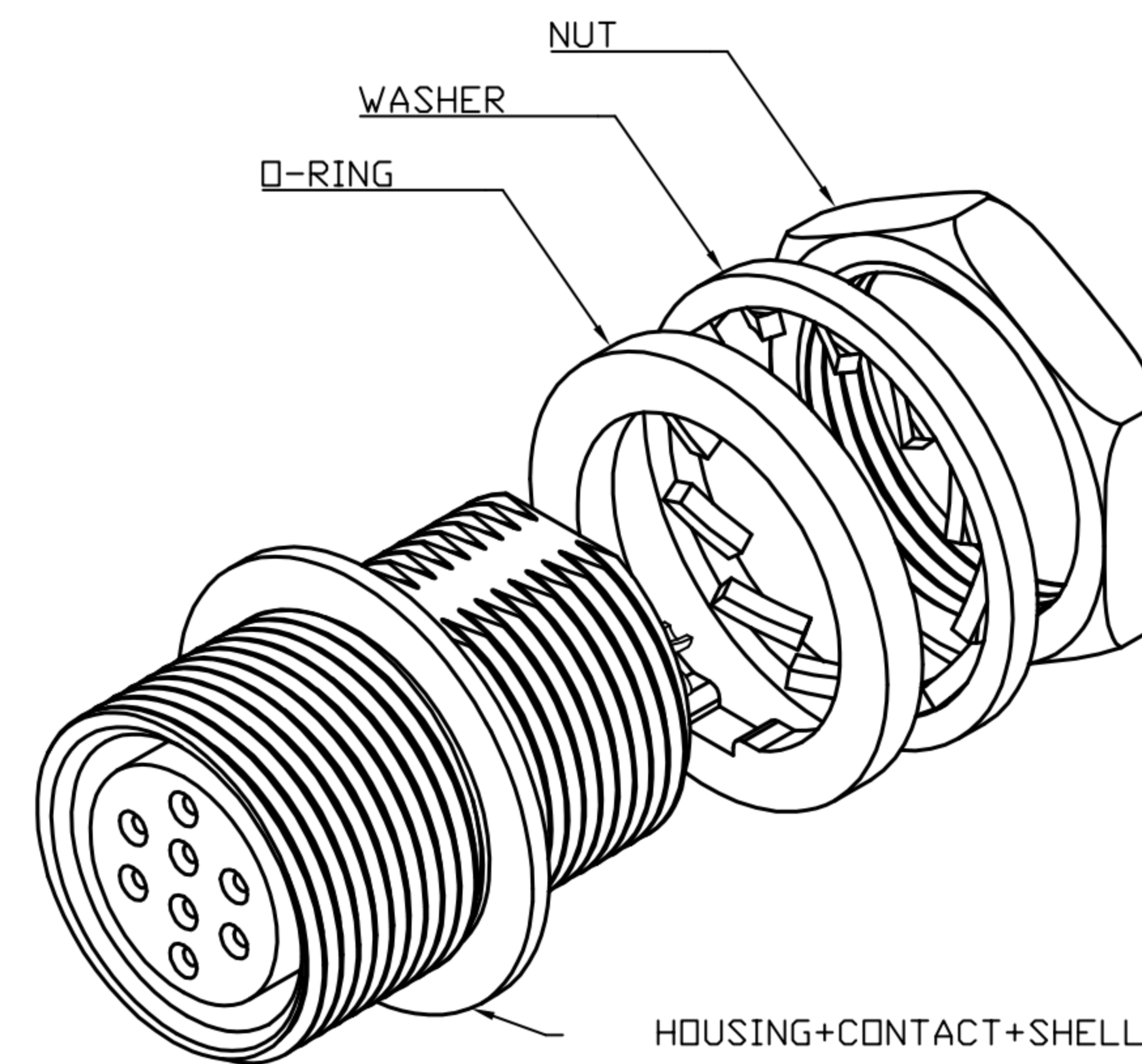

DRAWN	Jen Xie	APPEND	Emily Suen	UNIT	mm	TOLERANCE		广东科斯达电子科技有限公司 GUANG DONG KE SI DA ELECTRONIC TECHNOLOGY CO., LTD.	TITLE	防水头 M8*0.5 (F) 鐵板			SHEET	1/2
CHKED	Emily Suen			SCALE	1:1	.x ±0.20 .xx ±0.10 .xxx ±0.05 .xxxx ±0.03 ANGULA ±1°			PART NO.	SEE TABLE A	DWG NO.	QC5174	VERSION	C