

CUSTOMER DRAWING

REV.	DESCRIPTION	APPROVED BY	DATE	ECN NO.
A	RELEASE	Emily Suen	22/11/11'	
B				
C				
D				

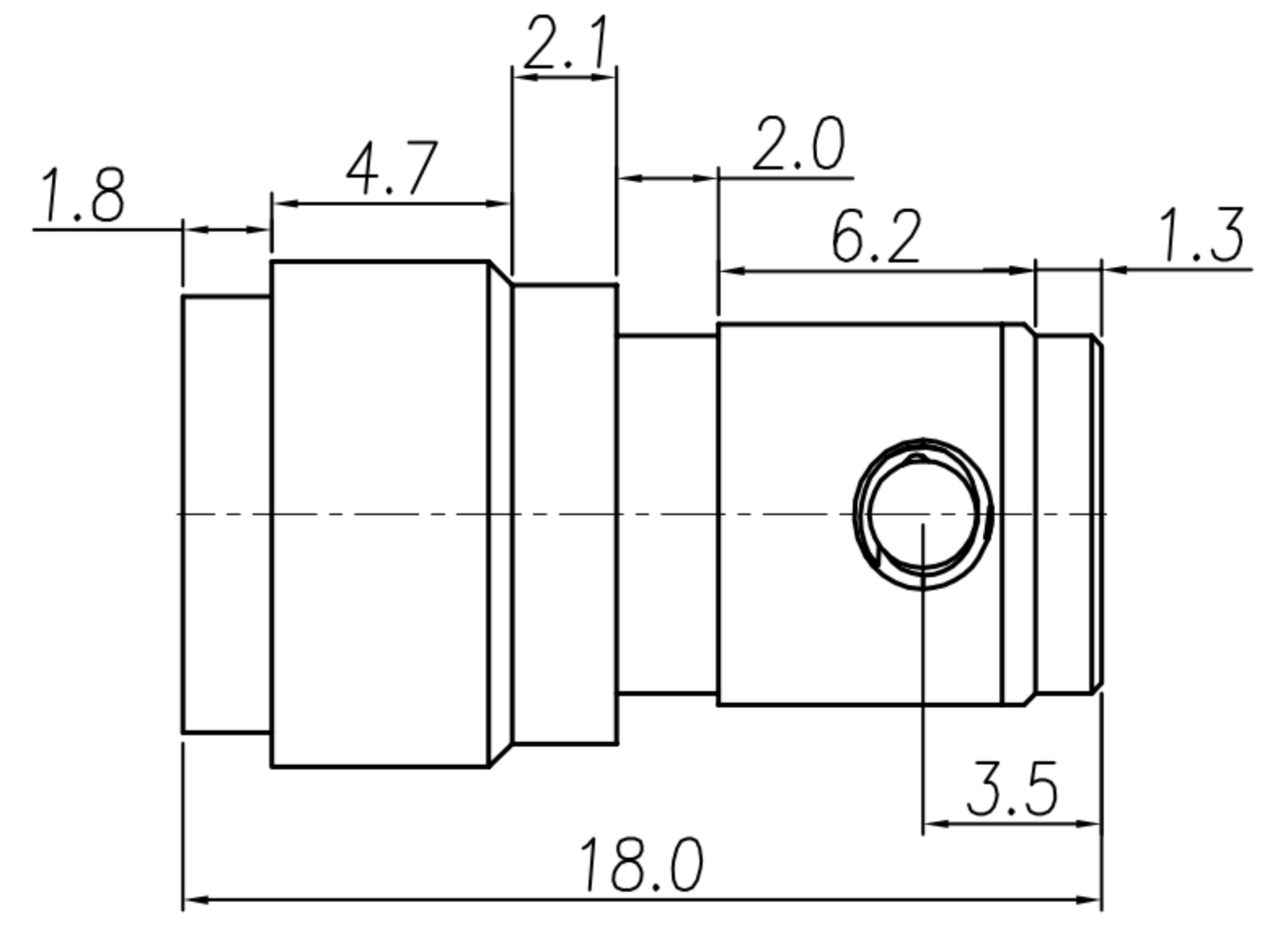
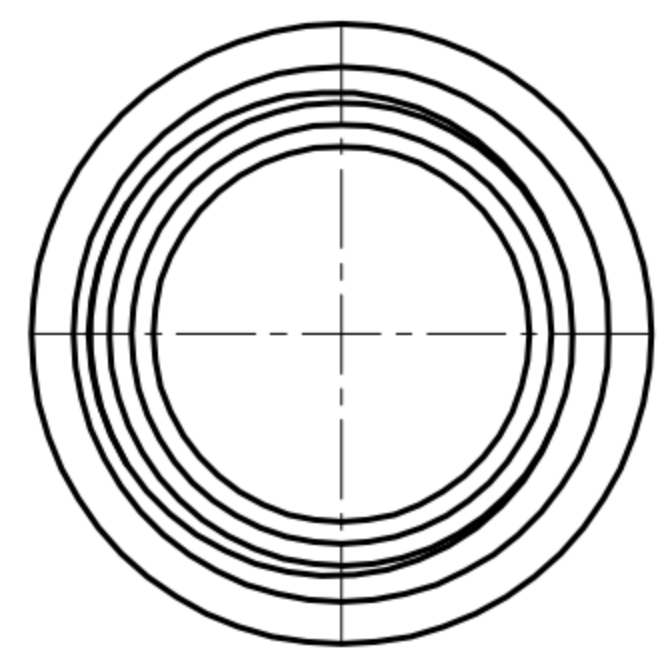
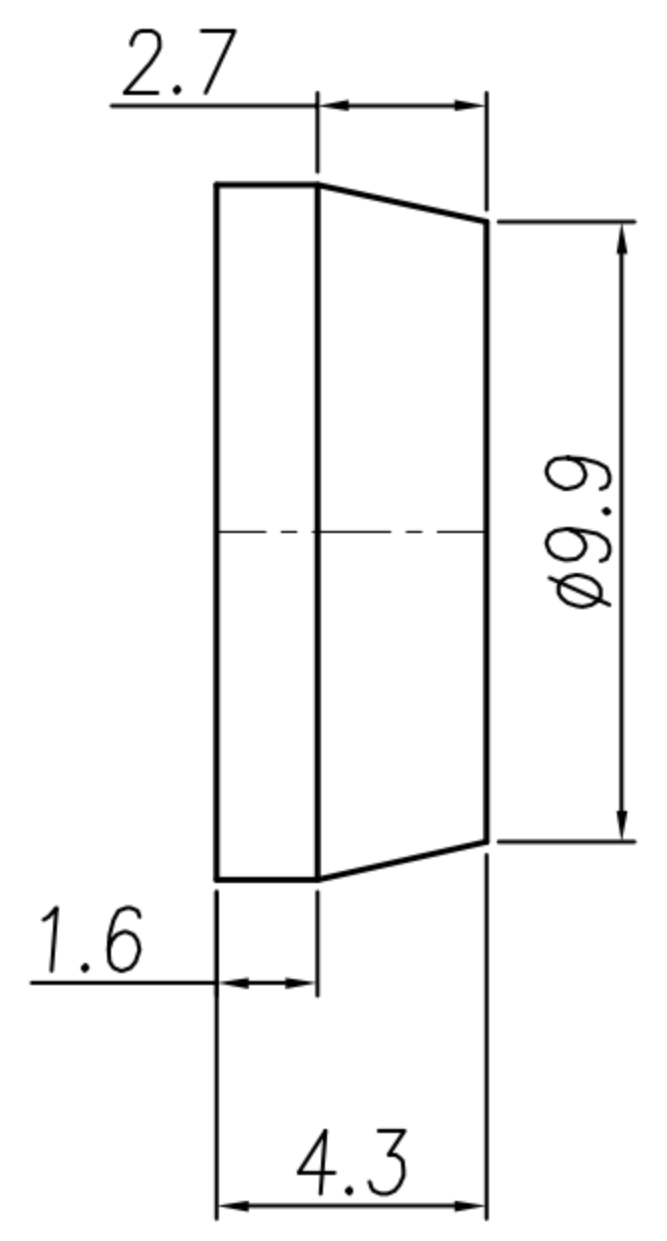
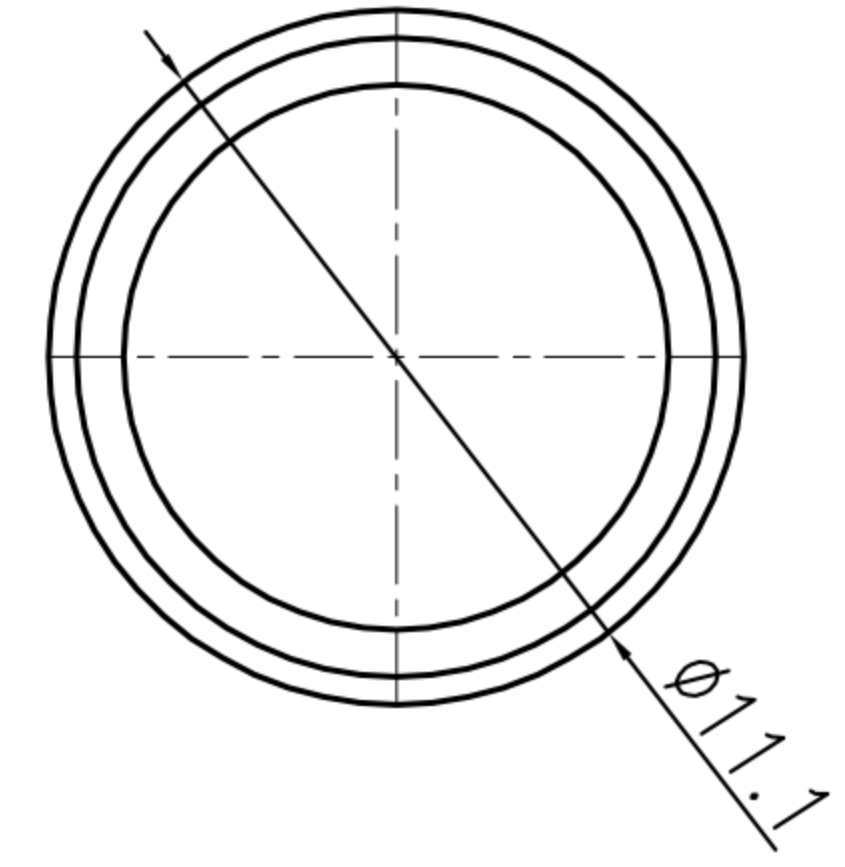
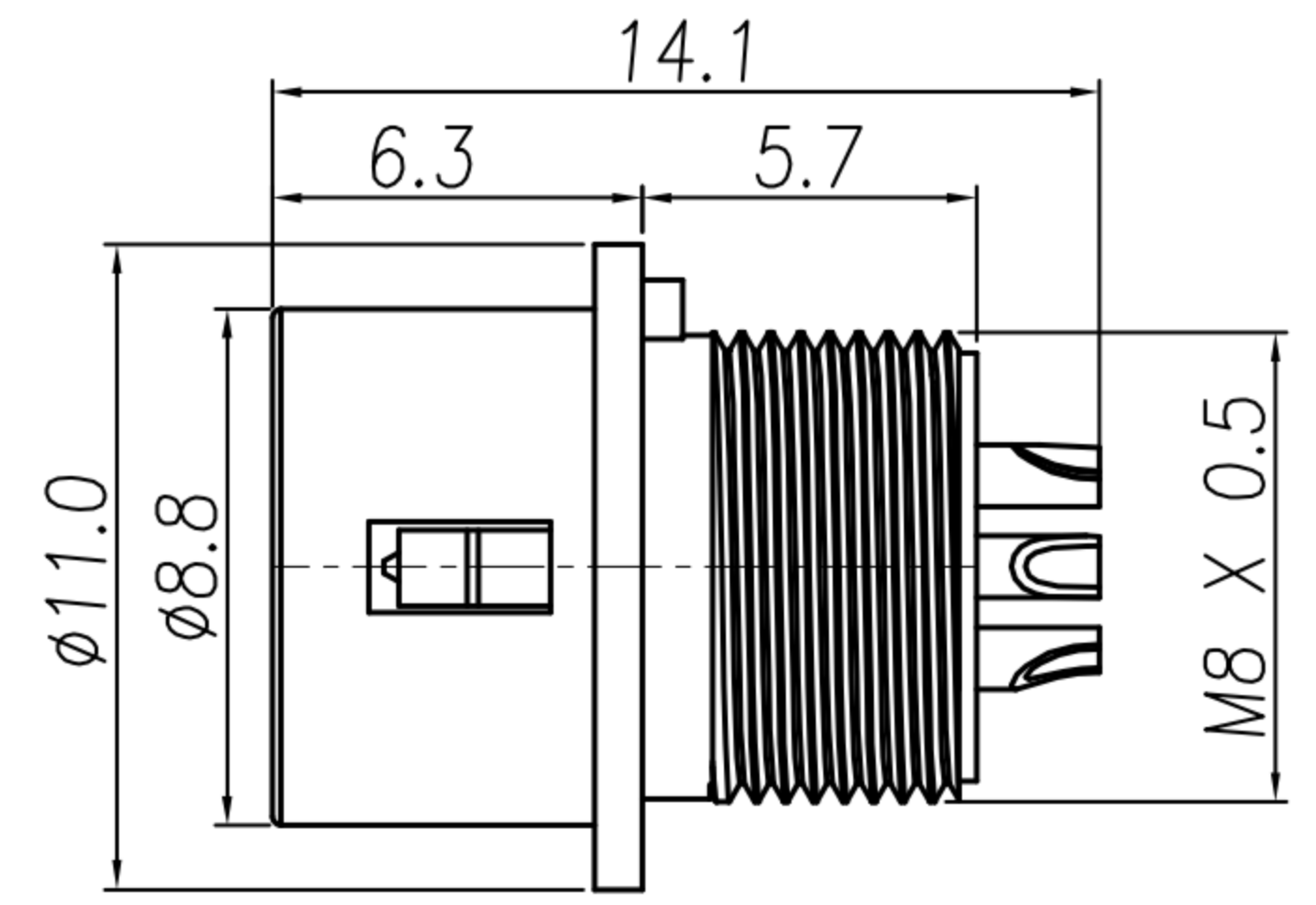

HOUSING + CONTACT + SHELL A

SHELL B

SHELL C

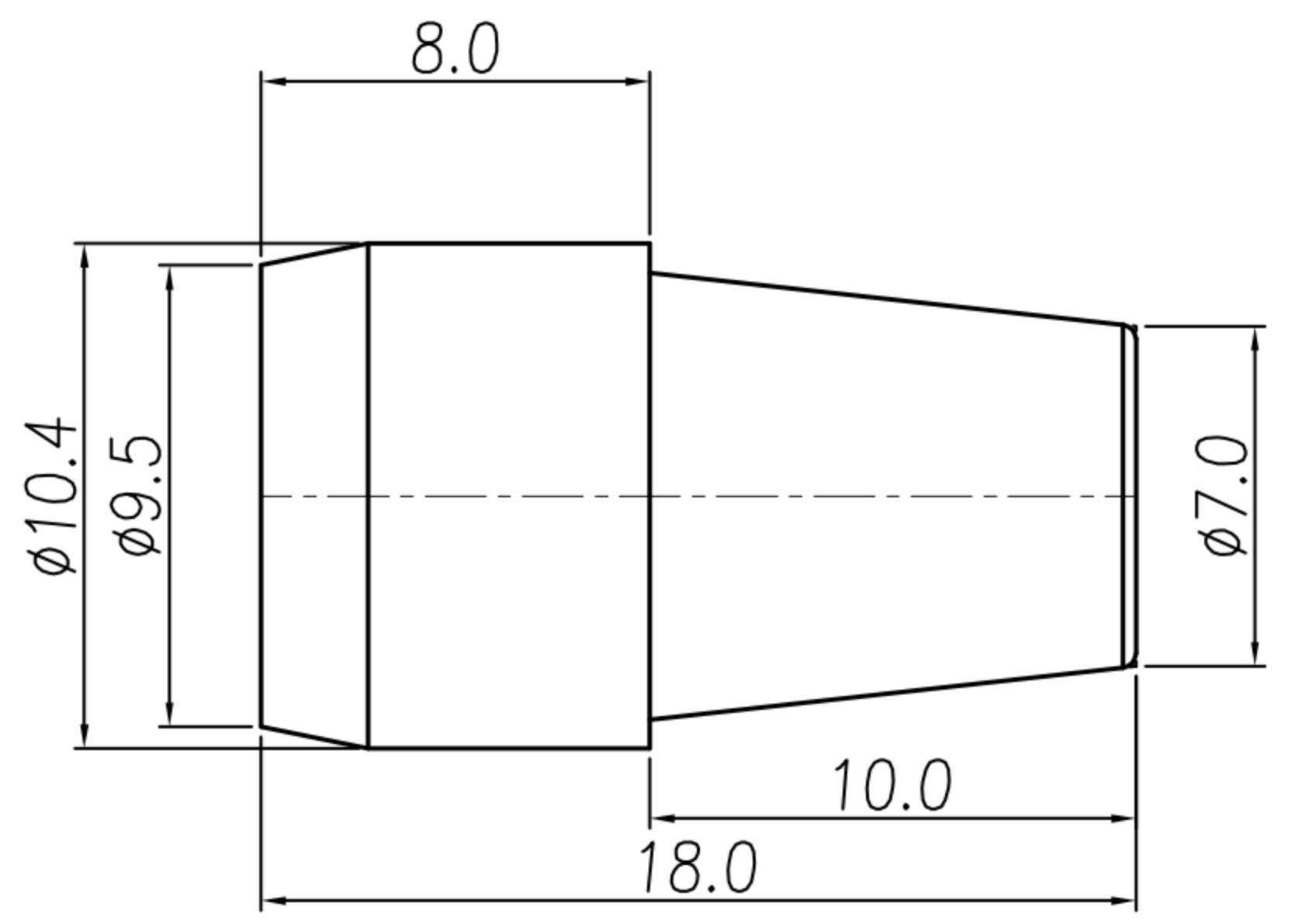
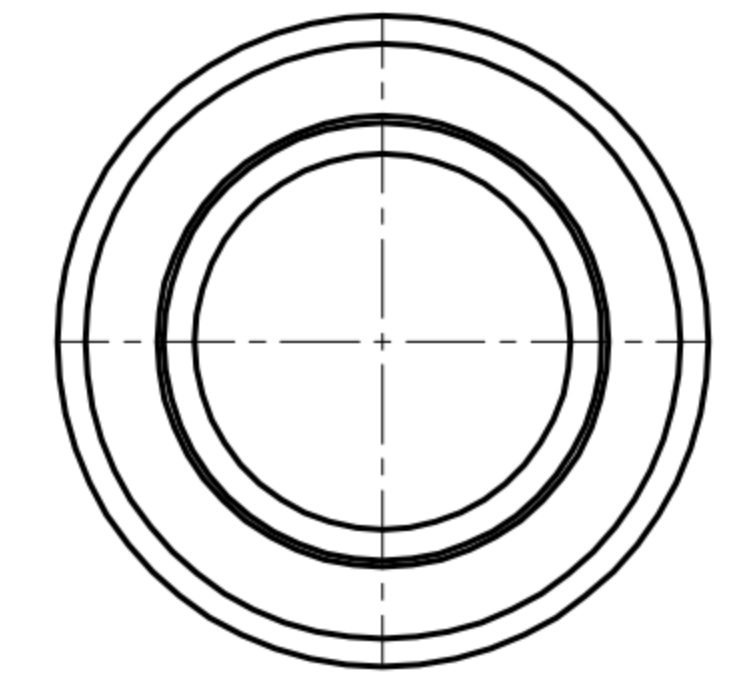
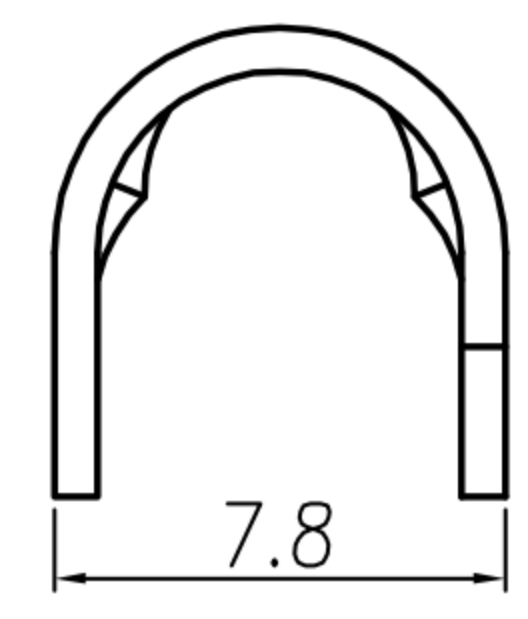
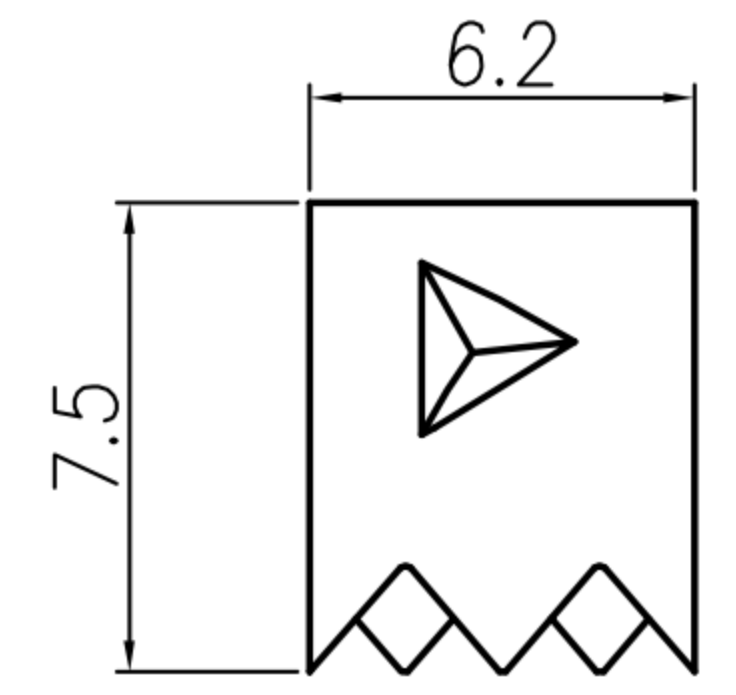
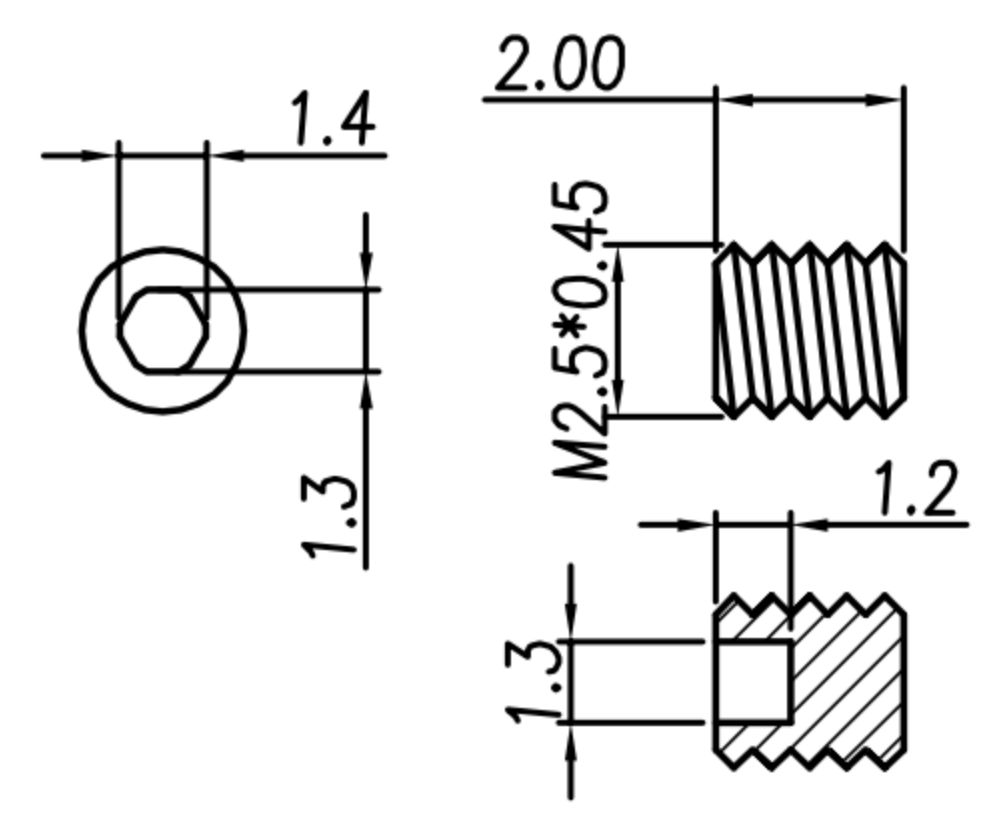

SCREW

CRAMP





SR

DRAWN	Mark Kao	APPV'L	Ku Chou	UNIT	mm	TOLERANCE .x ±0.20 .xx ±0.10 .xxx ±0.05 .xxxx ±0.03 ANGULA ±1°		广东科斯达电子科技有限公司 GUANG DONG KE SI DA ELECTRONIC TECHNOLOGY CO., LTD.	TITLE	DIN (M) JACK 连接器 (SHELL SIZE 7mm)			SHEET	2
CHK'D	Emily Suen			SCALE	1:1				PART NO.	SEE TABLE A	DWG NO.	QC5666	VERSION	A

CUSTOMER DRAWING

REV.	DESCRIPTION	APPROVED BY	DATE	ECN NO.
△A	RELEASE	Emily Suen	22/11/11'	
△B	CHANGE MATERIAL	Emily Suen	19/09/22'	
△C				
△D				

TABLE A

CONTACT ARRANGEMENT(FRONT VIEW)			
			
DI-04M2-07	DI-05M2-05	DI-06M2-06	DI-07M2-03

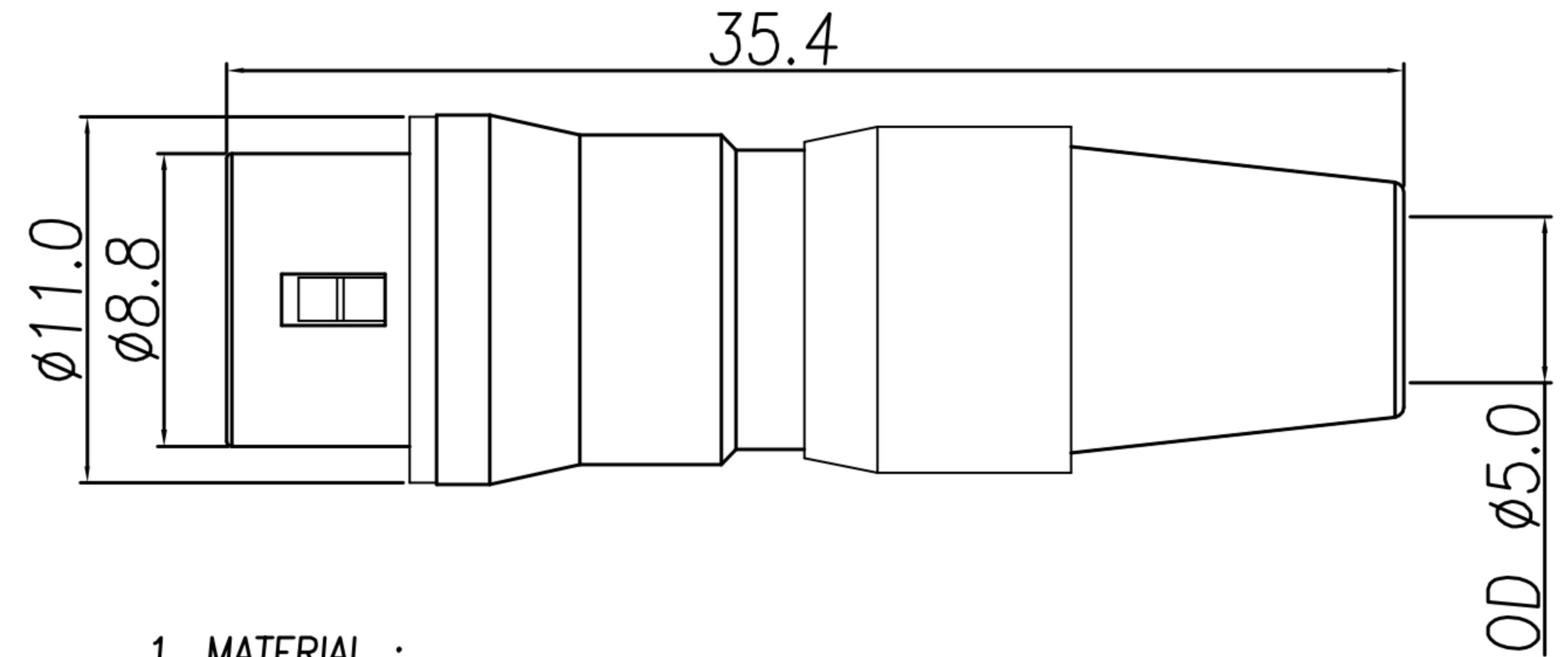

1. MATERIAL :

- △B 1-1. HOUSING : NYLON46 UL94V-0 ; COLOR : BLACK
- 1-2. CONTACT : BRASS
- 1-3. SHELL A : ZINC ALLOY
- 1-4. SHELL B : BRASS
- 1-5. SHELL C : BRASS
- 1-6. SCREW : ALLOY STEEL
- 1-7. CLAMP : BRASS
- 1-8. SR : NBR ; COLOR : BLACK

2. FINISH :

- 2-1. CONTACT : GOLD FLASH
- 2-2. SHELL A : NICKEL
- 2-3. SHELL B : NICKEL
- 2-4. SHELL C : NICKEL
- 2-5. SCREW : NICKEL

3. ELECTRICAL SPECIFICATION :

- 3-1. Rated current : 2A
- 3-2. Rated voltage : 4PIN 150V AC / 200V DC ;  
5~7PIN 100V AC / 140V DC

4. Environmental :

- 4-1. Operation Temperature : -25℃~85℃

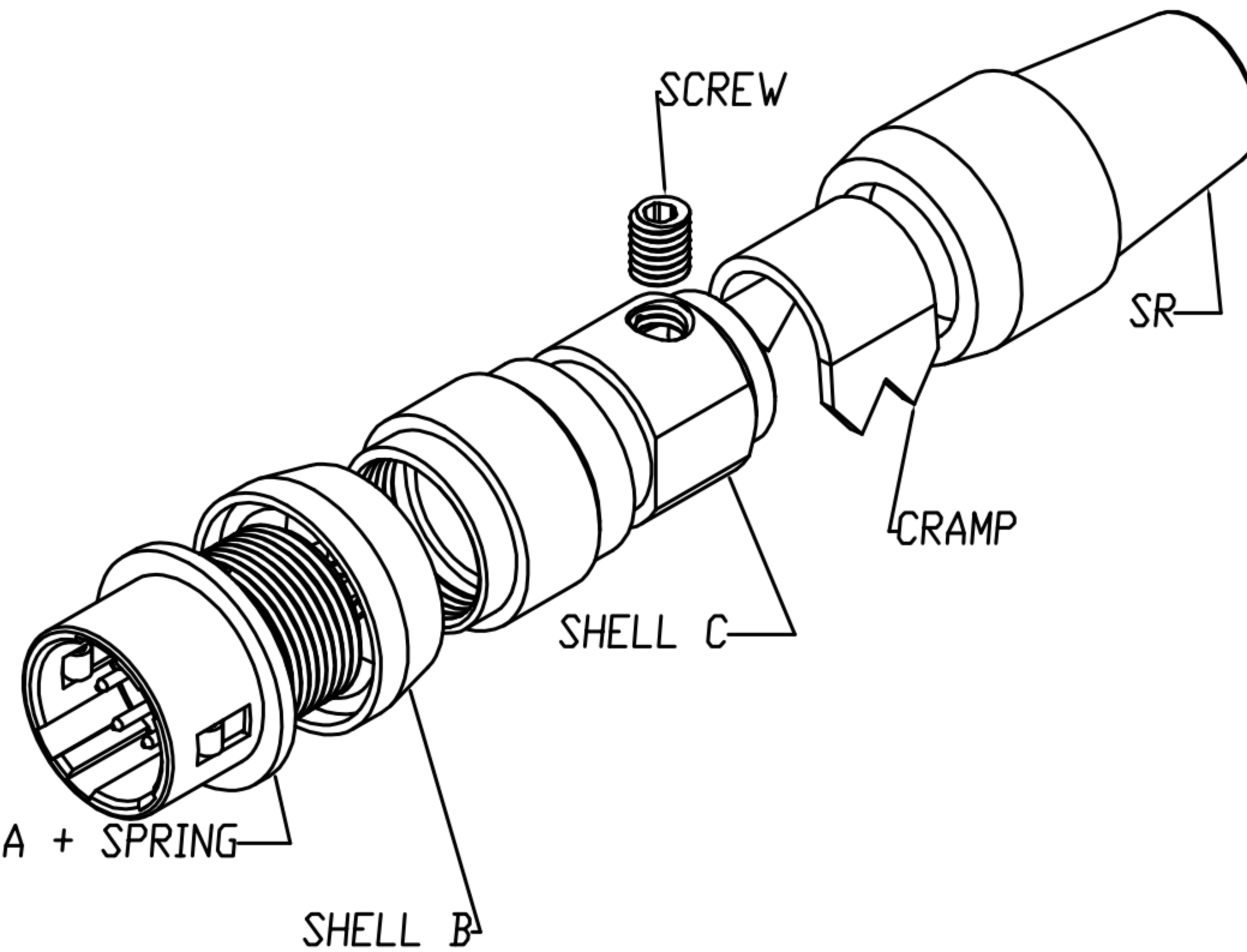

DRAWN	Mark Kao	APPVL	Ku Chou	UNIT	mm	TOLERANCE			 广东科斯达电子科技有限公司 GUANG DONG KE SI DA ELECTRONIC TECHNOLOGY CO., LTD.	TITLE	DIN (M) JACK 连接器 (SHELL SIZE 7mm)			SHEET	1/2
CHK'D	Emily Suen			SCALE	1:1	PART NO.				SEE TABLE A	DWG NO.	QC5666	VERSION	B	