

CUSTOMER DRAWING

REV.	DESCRIPTION	APPROVED BY	DATE	ECN NO.
A	RELEASE	Emily Suen	25/10/11'	
B	ADD TABLE A	KU	02/05/18'	
C				

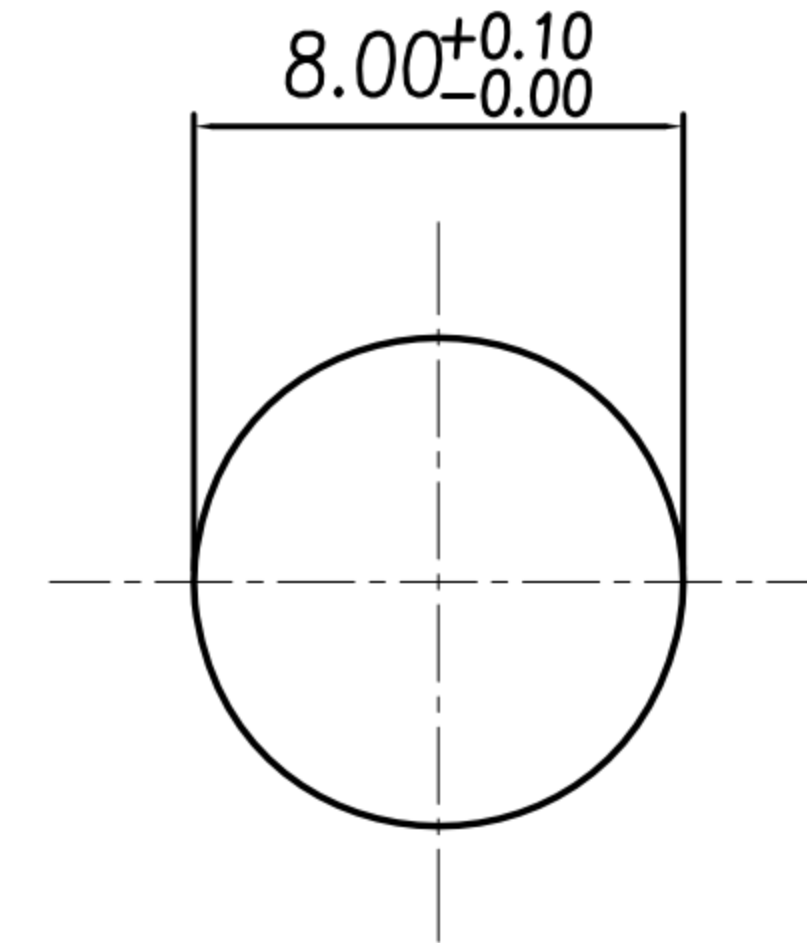

RECOMMEND PANEL CUT-OUT

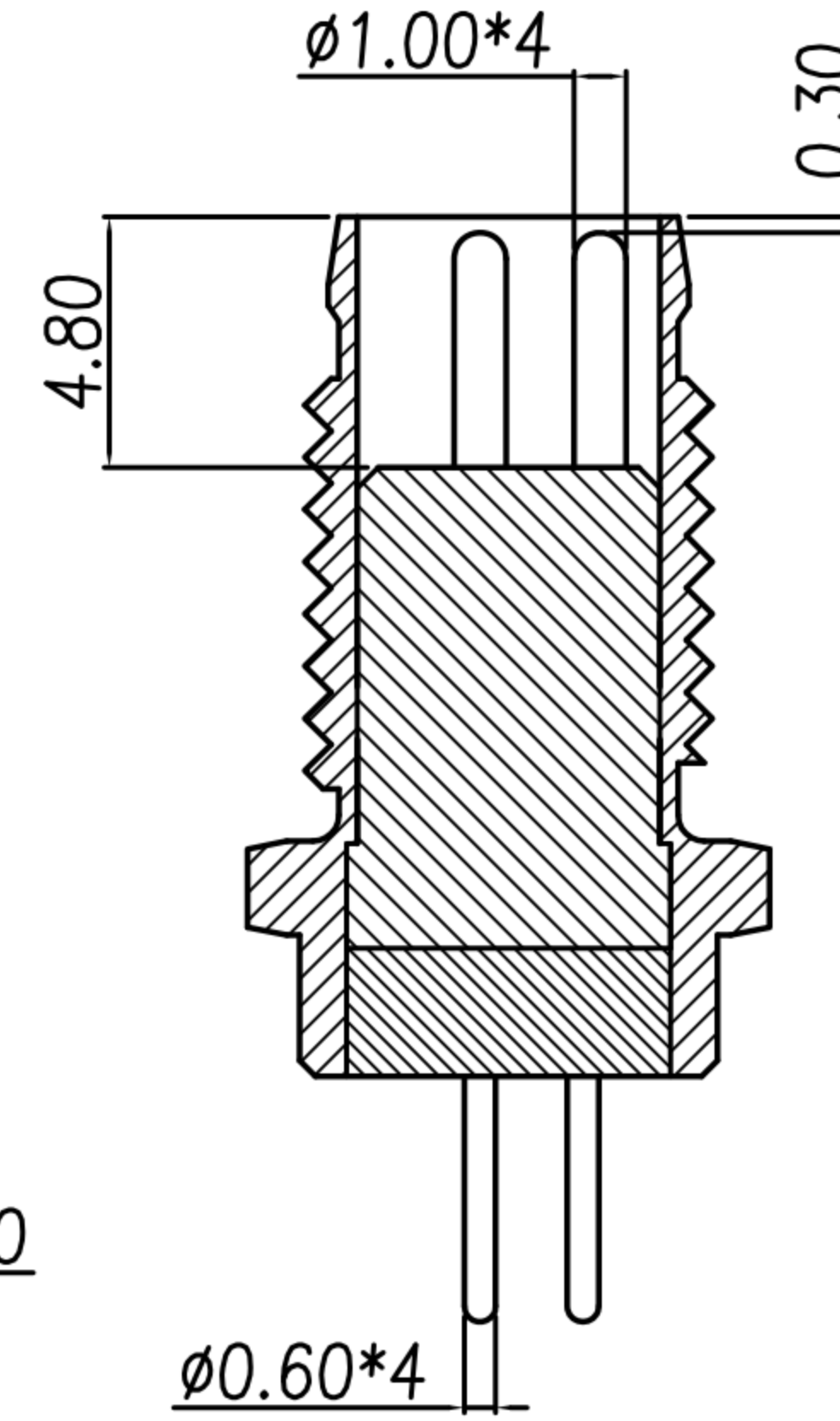
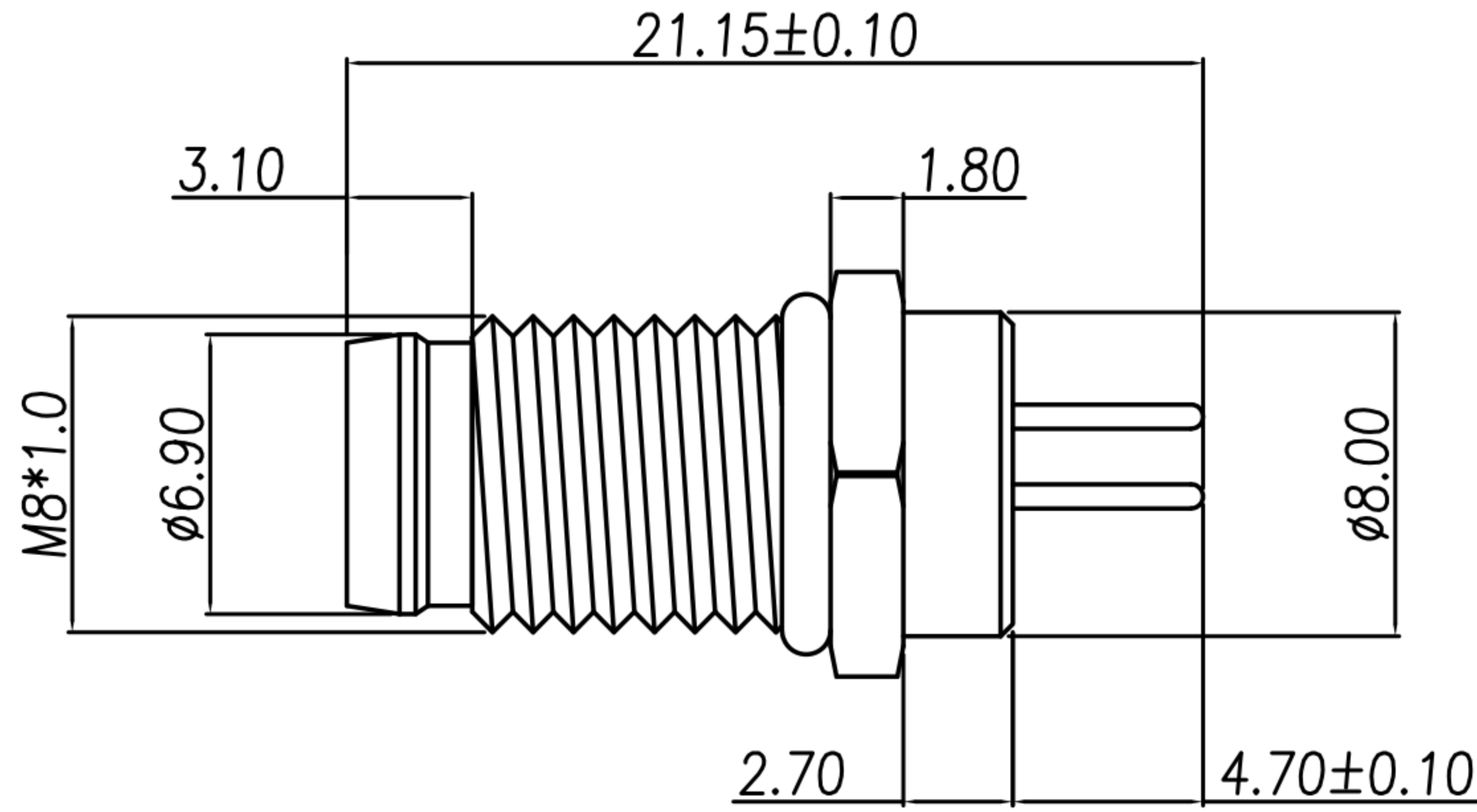
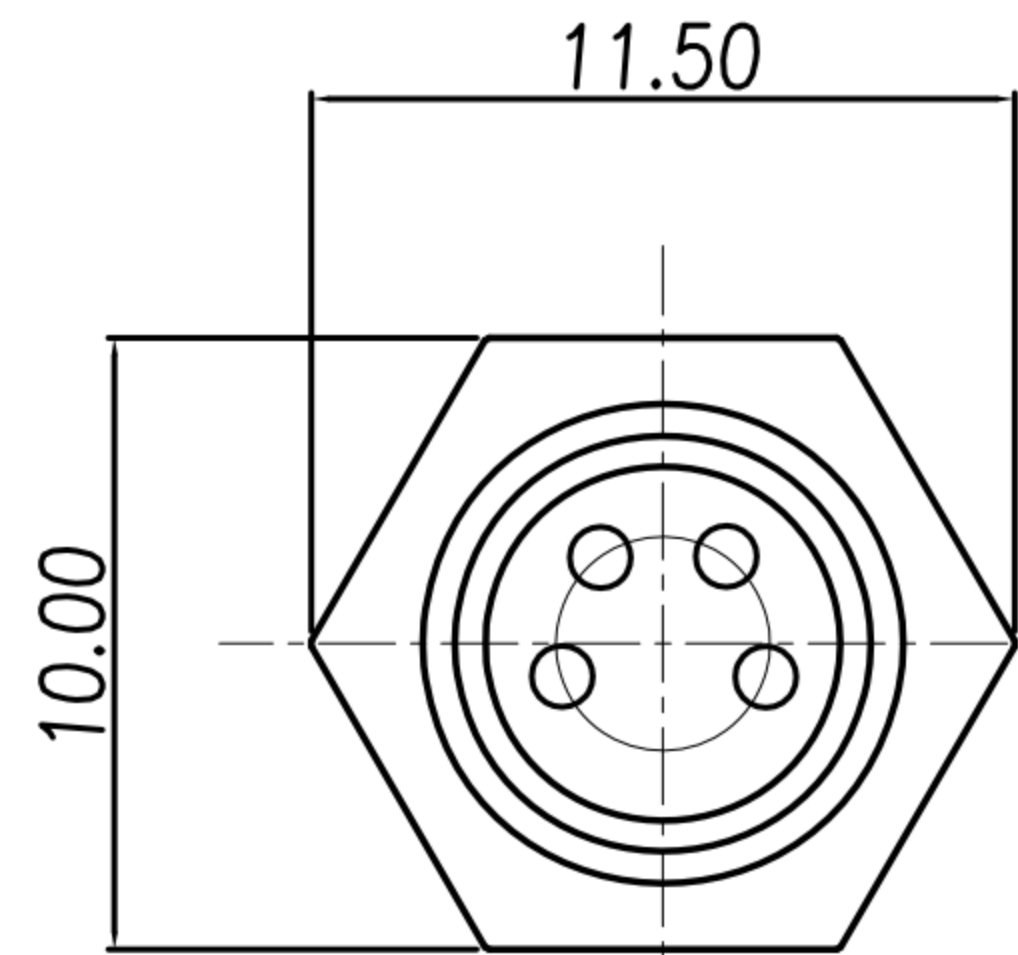
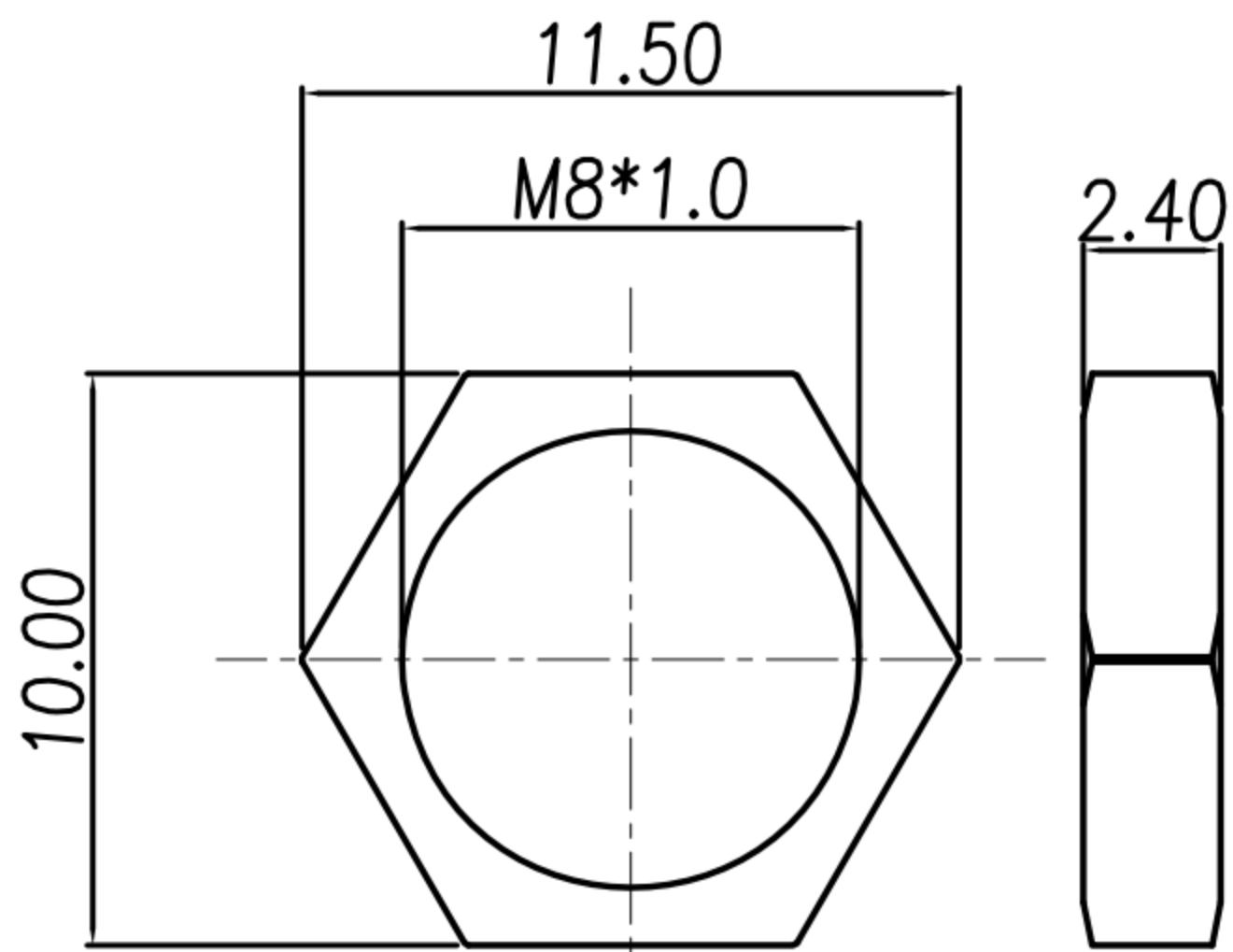

NUT

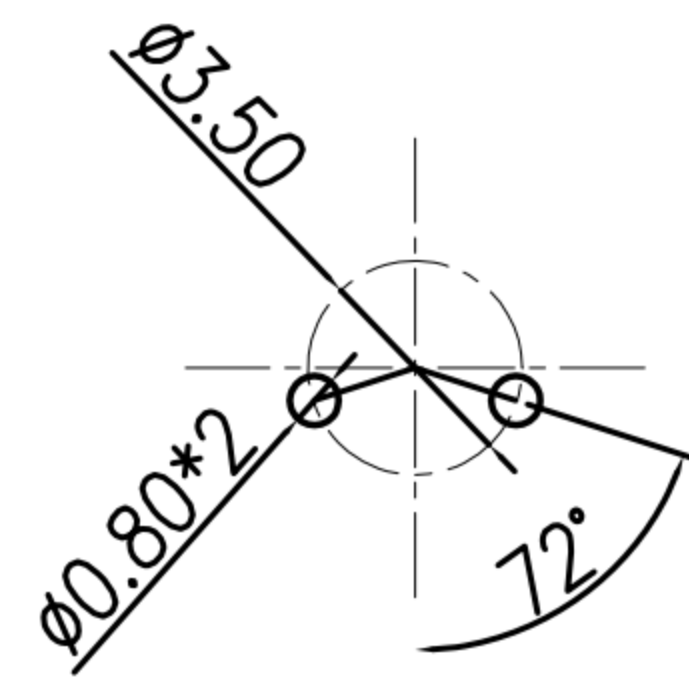

2 PIN

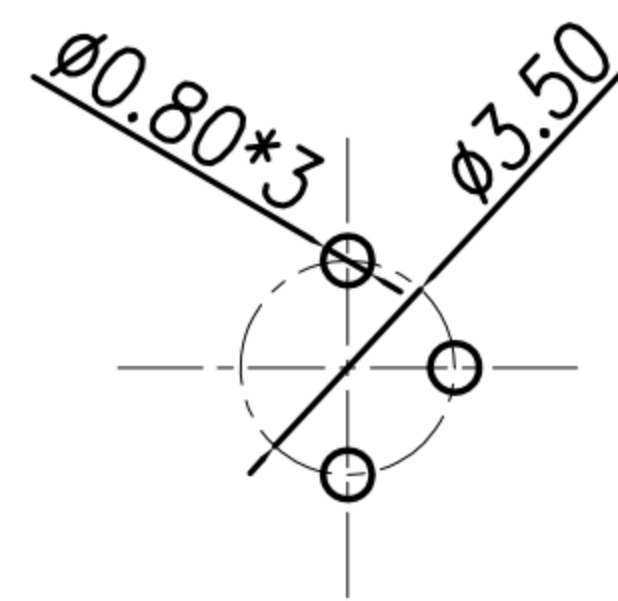

3 PIN

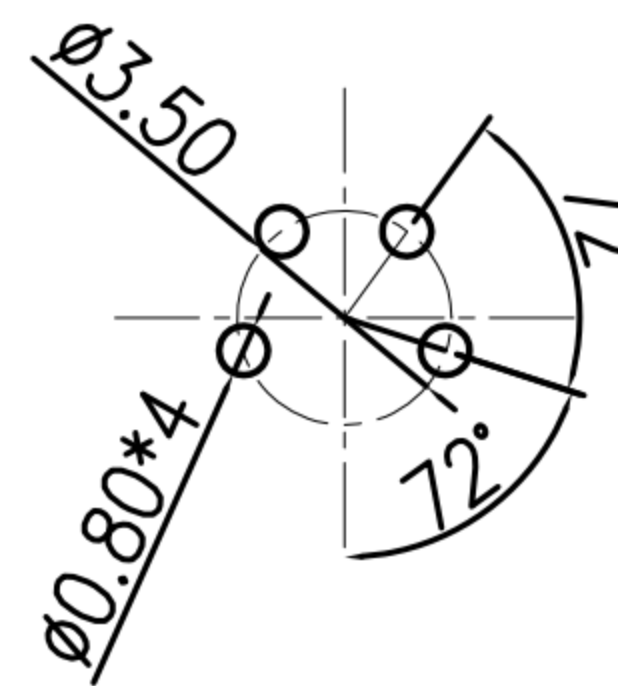

4 PIN

RECOMMEND PCB LAYOUT

TABLE A

2PIN	3PIN	4PIN	
WP-02M3-01-11 WP-02M3-07-11	WP-03M2-26 WP-03M3-09-11	WP-04M2-65 WP-04M2-209-11	
WP-04M2-65	GOLD FLASH	WP-04M2-209-11	GOLD 10u"
WP-03M2-26	GOLD FLASH	WP-03M3-09-11	GOLD 10u"
WP-02M3-01-11	GOLD FLASH	WP-02M3-07-11	GOLD 10u"
PART NO	FINISH	PART NO	FINISH

- MATERIAL :
 - 1-1. HOUSING : PBT ; COLOR : BLACK
 - 1-2. CONTACT : BRASS
 - 1-3. SHELL : BRASS
 - 1-4. O-RING : NBR ; COLOR : BLACK
 - 1-5. NUT : BRASS
- FINISH :
 - 2-1. CONTACT : SEE TABLE A
 - 2-2. SHELL : NICKEL PLATED.
 - 2-3. NUT : NICKEL PLATED.
- ELECTRICAL SPECIFICATION :
 - 3-1. Rated current : 4A
 - 3-2. Rated voltage : 60V
 - 3-3. Water proof : IP67
- Environmental :
 - 4-1. Operation Temperature : -20℃~85℃

DRAWN	Ku Chou	APPEND	Emily Suen	UNIT	mm	TOLERANCE			TITLE	防水頭 (M) 前鎖板M8*1.0 插板式			SHEET	1
CHKED	Ku Chou			SCALE	1:1	.x ±0.20 .xx ±0.10 .xxx ±0.05 .xxxx ±0.03 ANGULA ±1°			PART NO.	SEE TABLE A	DWG NO.	QC5562	VERSION	B