

CUSTOMER DRAWING

REV.	DESCRIPTION	APPROVED BY	DATE	ECN NO.
A	RELEASE	Emily Suen	30/12/11'	
B	CHANGE CONTACT PLATED	Ku Chou	10/06/19	ECN-19006
C				

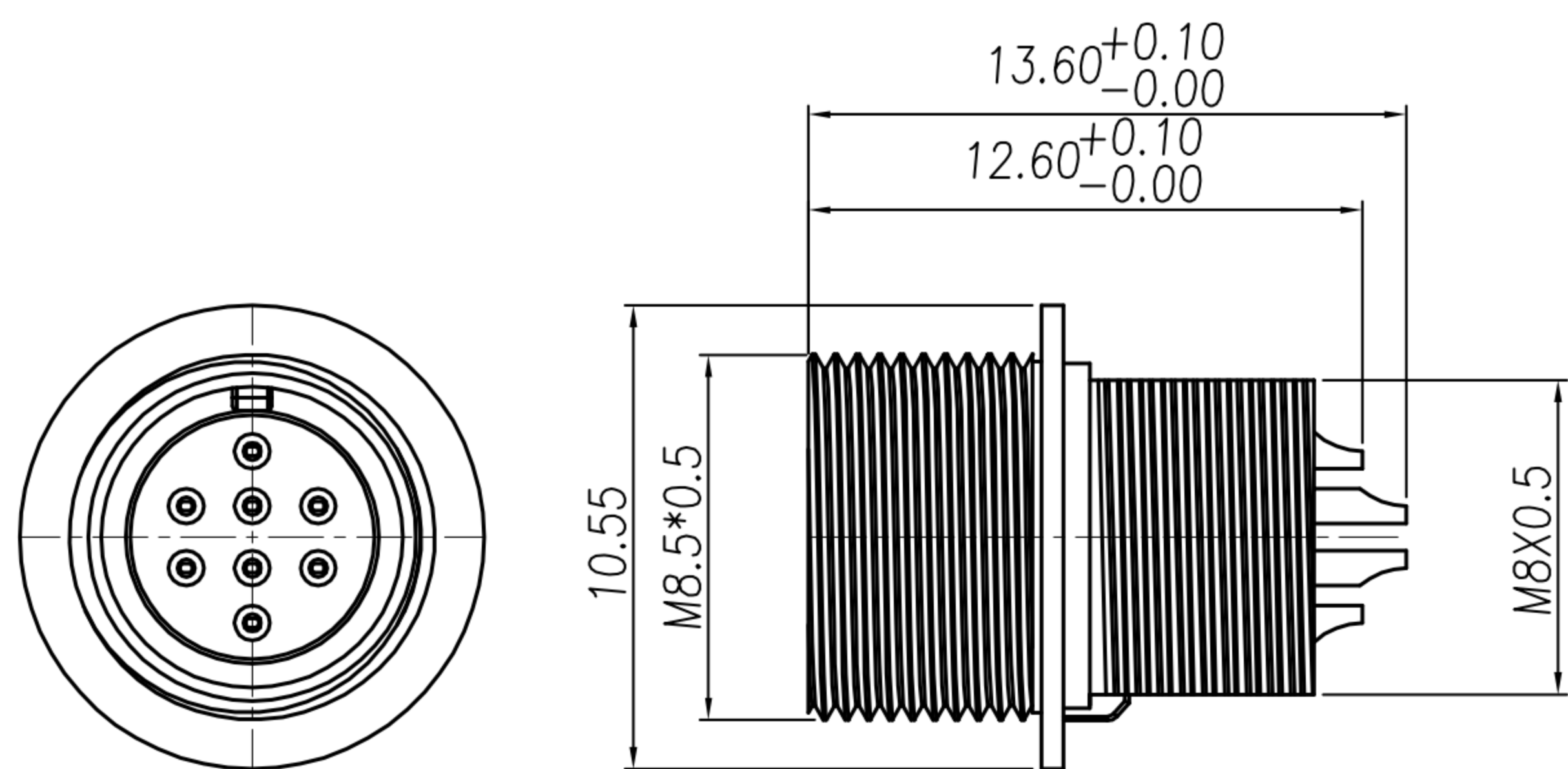

HOUSING+CONTACT+SHELL A

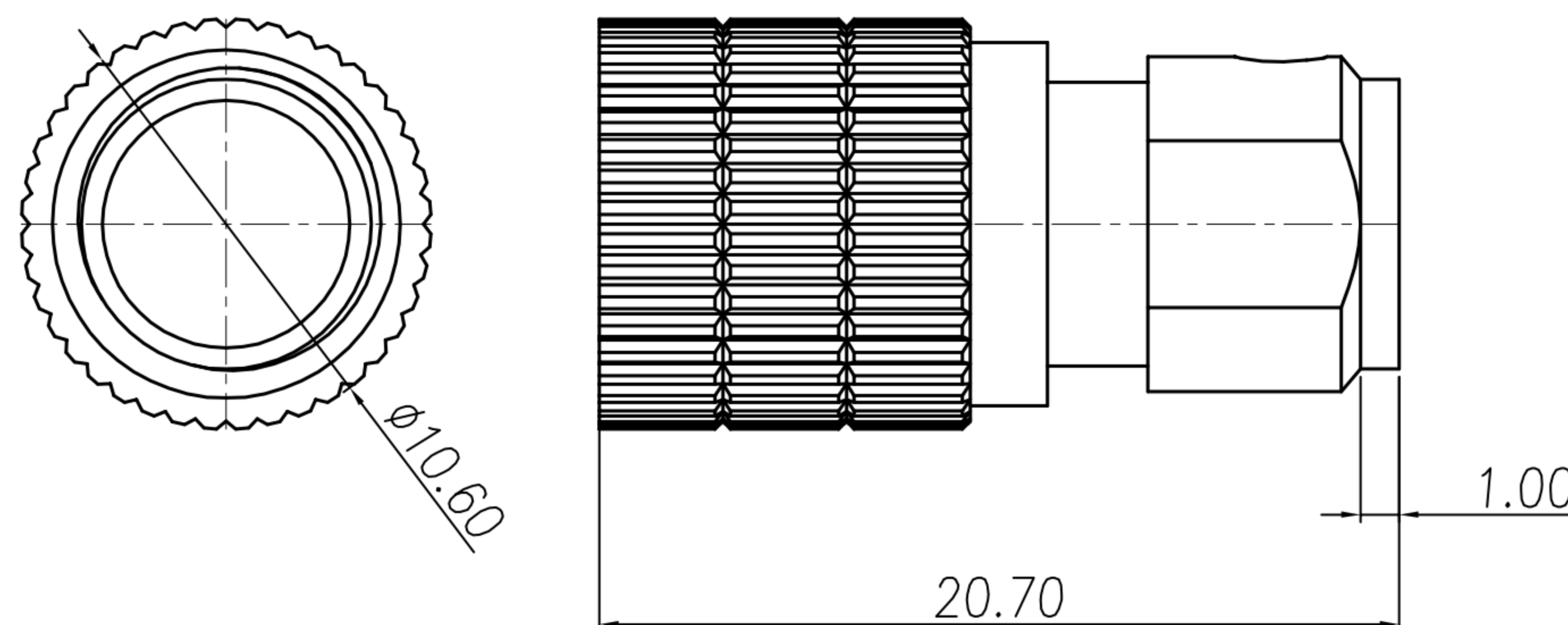

SHELL B+O-RING A

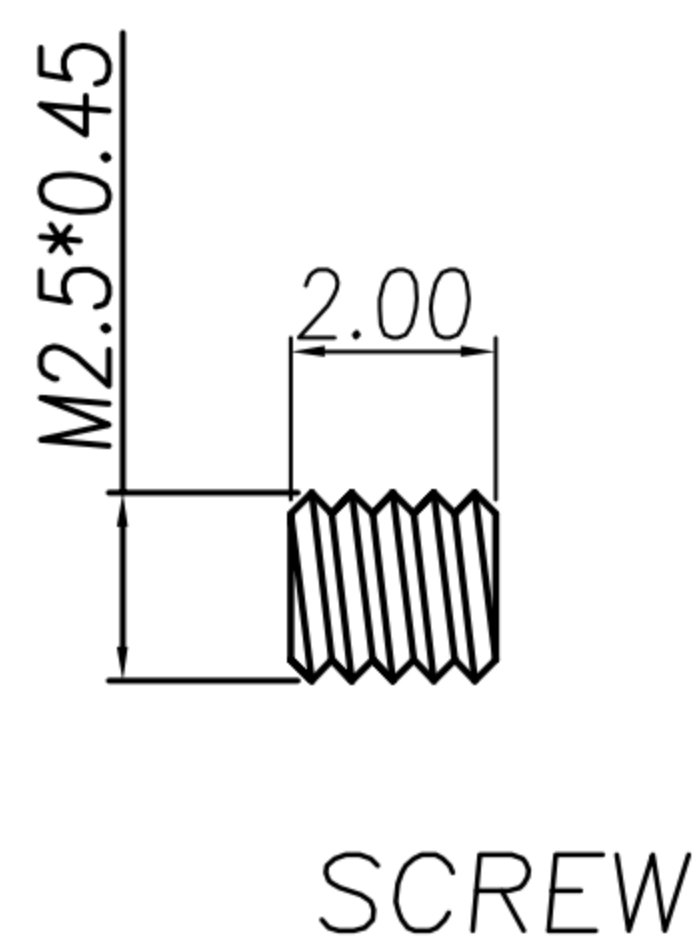

SCREW

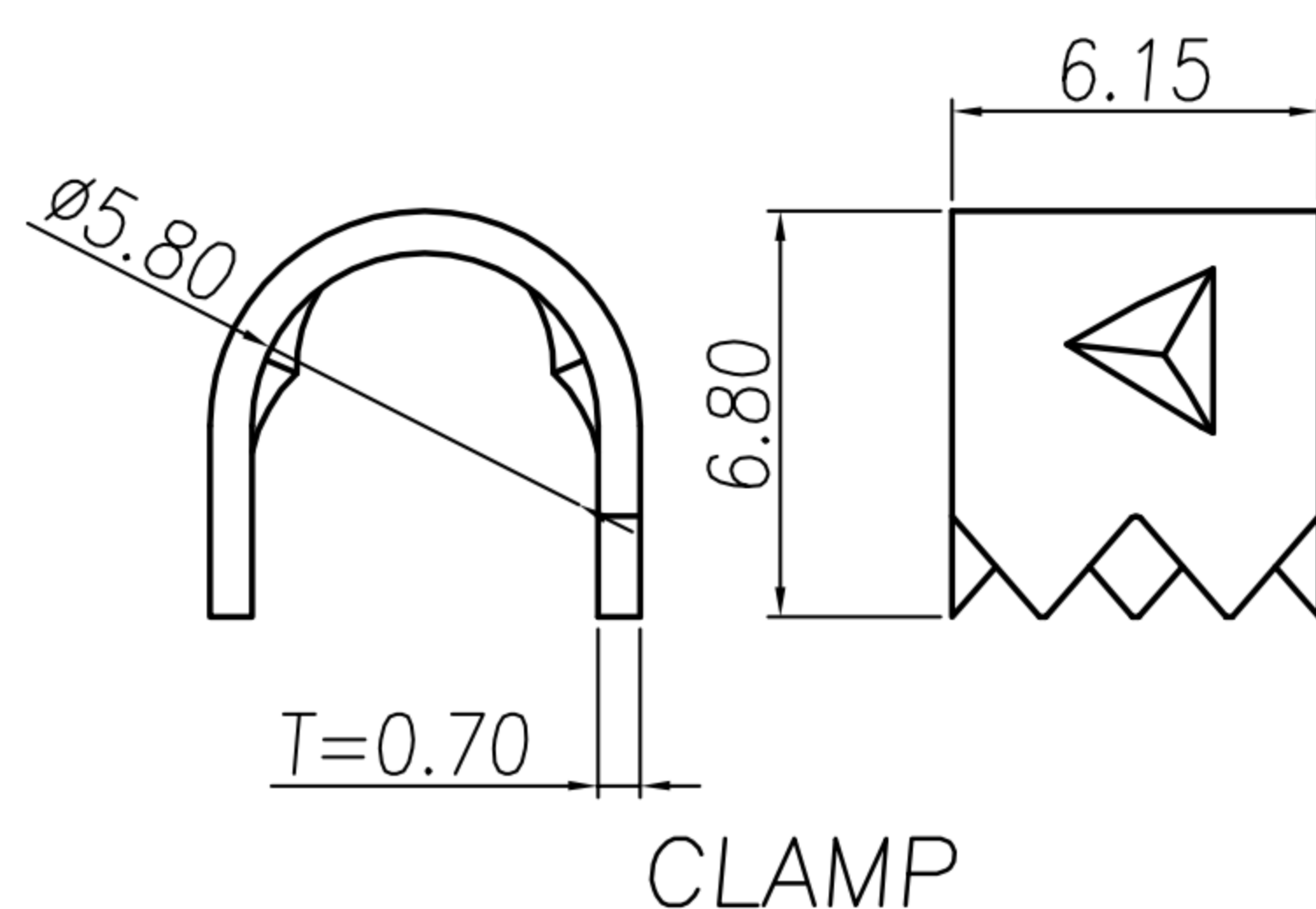
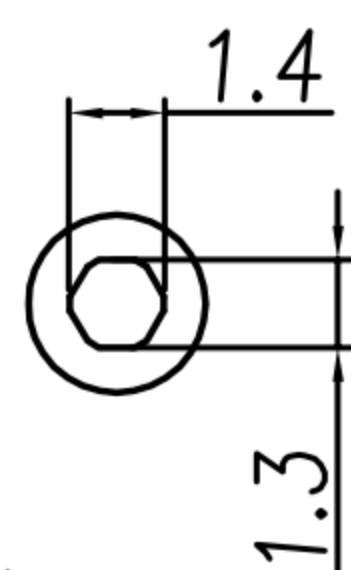

CLAMP

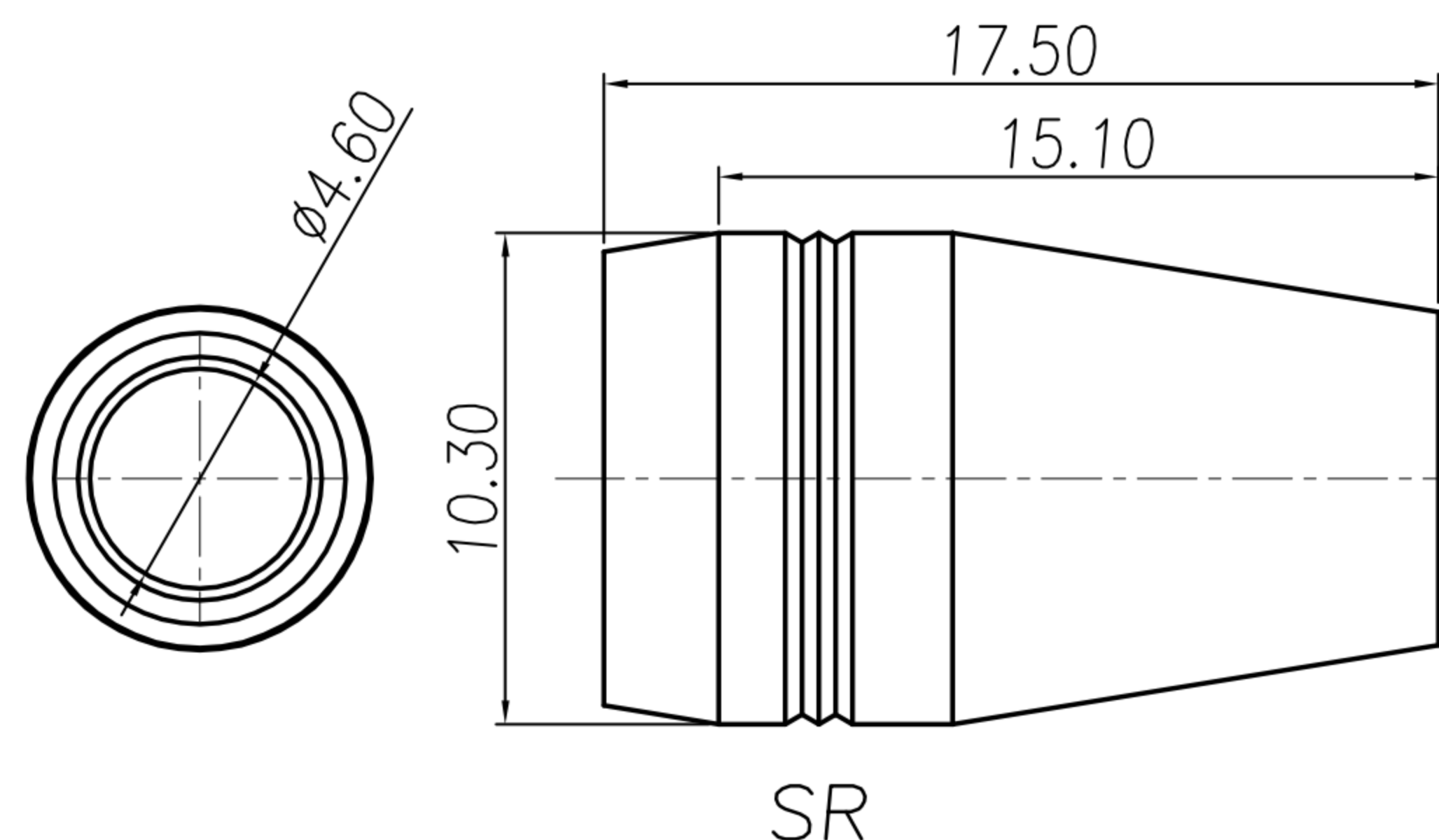

SR

DRAWN	Mark Kao	APP'D	Ku Chou	UNIT	mm	TOLERANCE		广东科斯达电子科技有限公司 GUANG DONG KE SI DA ELECTRONIC TECHNOLOGY CO., LTD.	TITLE	DIN M8*0.5 (F) 線端式(SHELL:JACK)			SHEET	2/2
CHK'D	Emily Suen			SCALE	1:1	.x ±0.20 .xx ±0.10 .xxx ±0.05 .xxxx ±0.03 ANGULA ±1°			PART NO.	SEE TABLE A	DWG NO.	QC5631	VERSION	B

CUSTOMER DRAWING

REV.	DESCRIPTION	APPROVED BY	DATE	ECN NO.
△A	RELEASE	Emily Suen	30/12/11'	
△B	CHANGE CONTACT PLATED	Ku Chou	10/06/19	ECN-19006
△C	CHANGE MATERIAL	Ku Chou	16/09/22'	

1. MATERIAL :

- △C 1-1. HOUSING : NYLON 66 UL94V-0 ; COLOR : BLACK
- 1-2. CONTACT : PHOSPHOR BRONZE
- 1-3. SHELL A : ZINC ALLOY
- 1-4. SHELL B : BRASS
- 1-5. O-RING A : NBR ; COLOR : BLACK
- 1-6. SCREW : ALLOY STEEL
- 1-7. CLAMP : BRASS
- 1-8. SR : TPR

2. FINISH :

- 2-1. CONTACT A : 10u" MIN. GOLD PLATED △B
- 2-2. SHELL A : NICKEL PLATED 60u" ~ 100u" OVER ALL
- 2-3. SHELL B : NICKEL PLATED 60u" ~ 100u" OVER ALL
- 2-4. SCREW : NICKEL PLATED 60u" ~ 100u" OVER ALL

3. ELECTRICAL SPECIFICATION :

- 3-1. Rated current : 1A
- 3-2. Rated voltage : 30V AC , 42V DC

4. Environmental :

- 4-1. Operation Temperature : -25℃~85℃

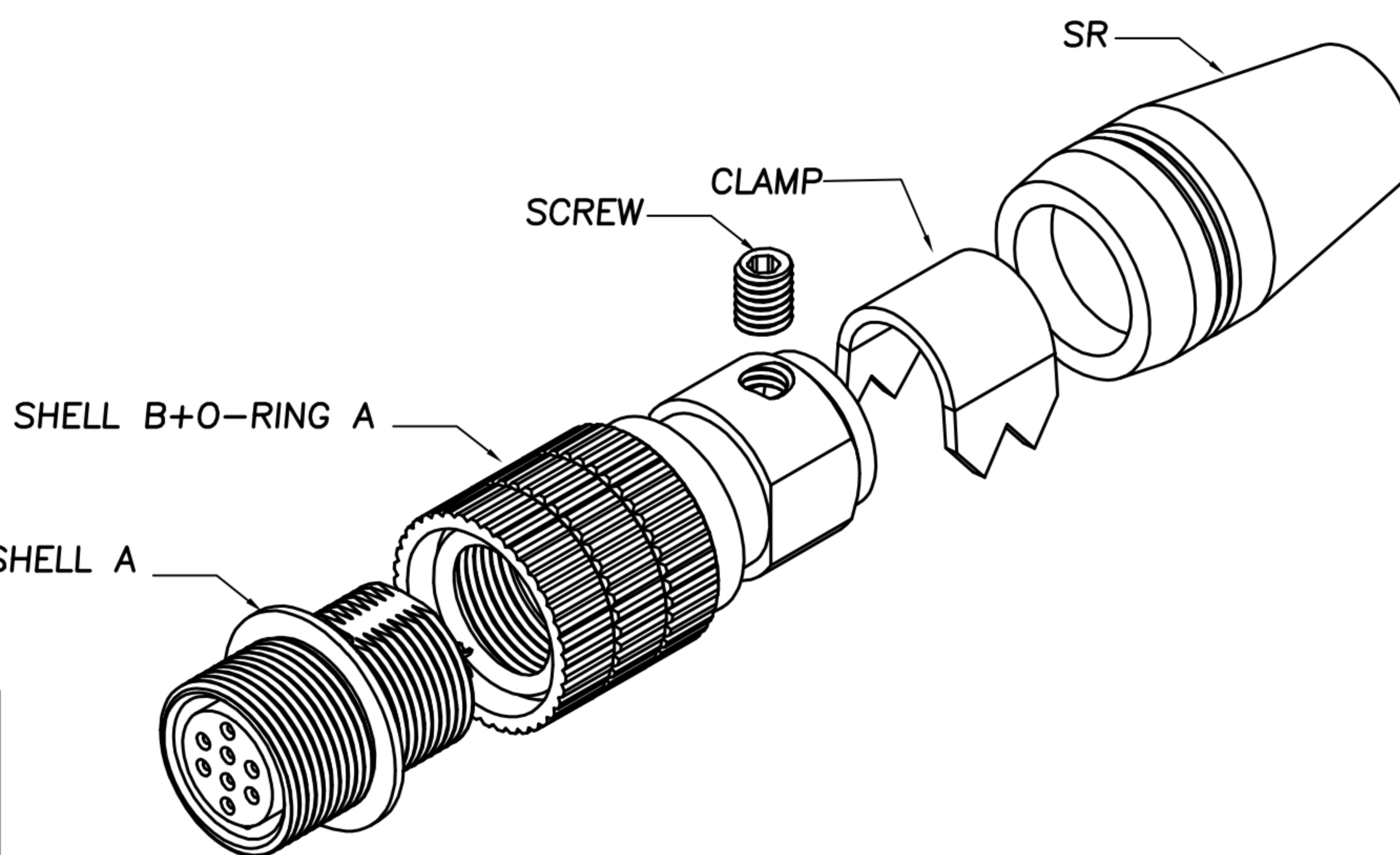
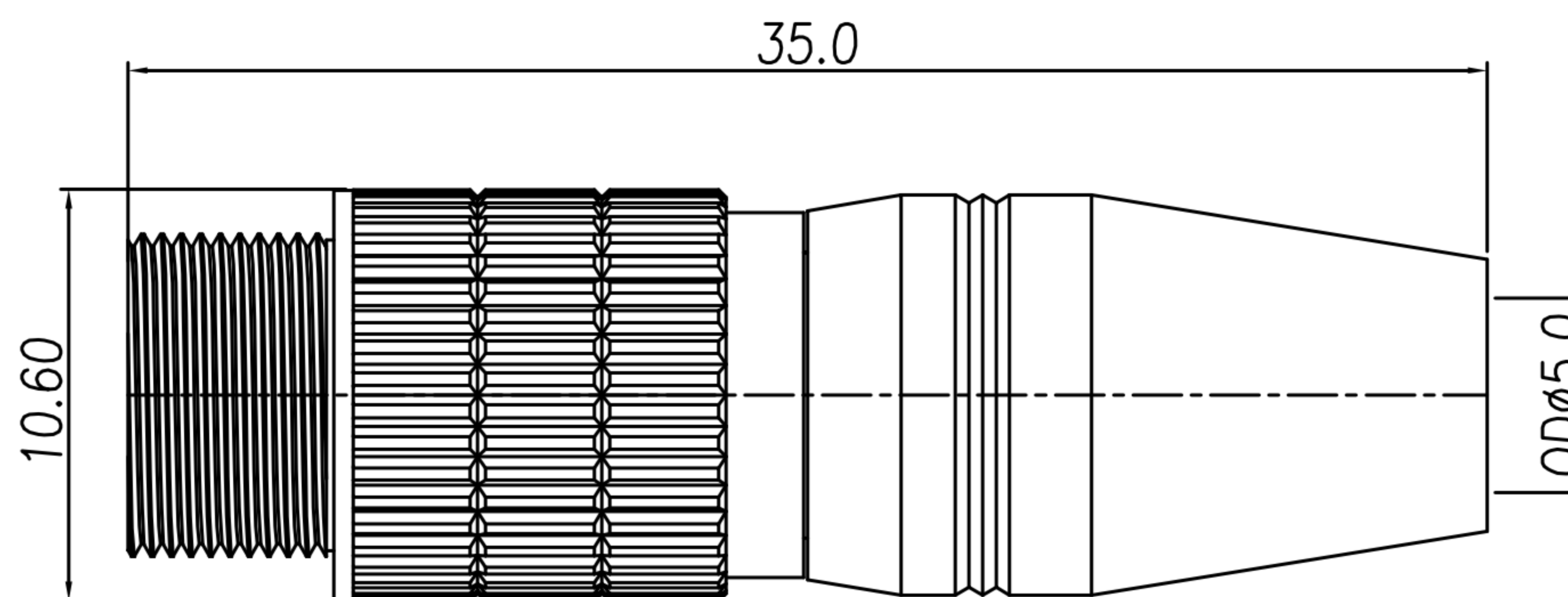
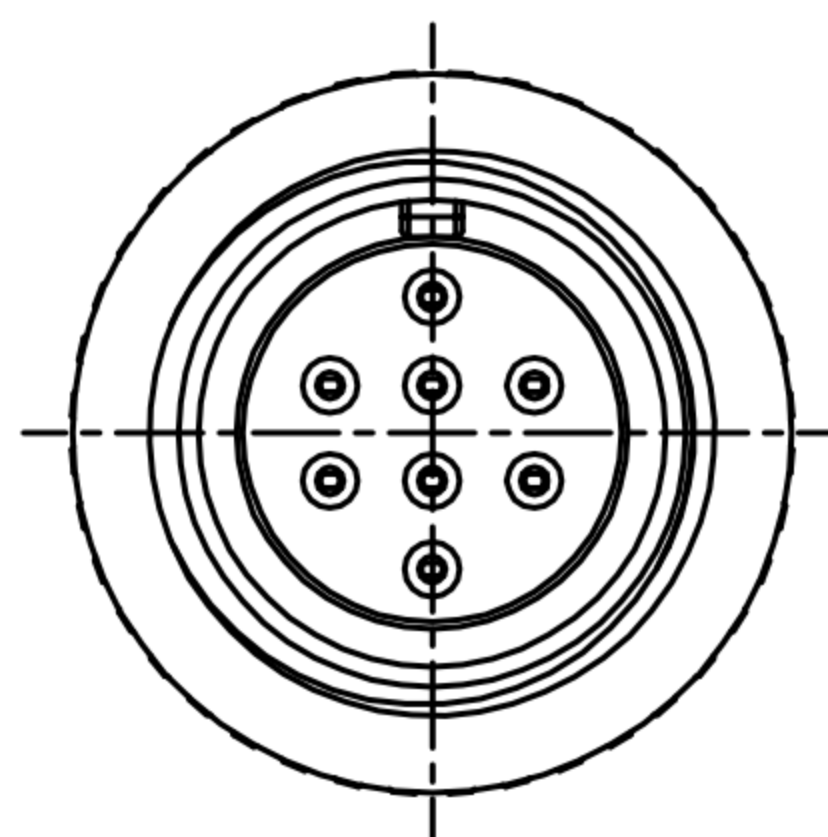

TABLE A

DI-04F2-03(4P)	DI-06F2-04(6P)	DI-08F2-03(8P)

DRAWN	Mark Kao	APP'D	Ku Chou	UNIT	mm	TOLERANCE			TITLE	DIN M8*0.5 (F) 線端式(SHELL:JACK)			SHEET	1/2
CHK'D	Emily Suen			SCALE	1:1				PART NO.	SEE TABLE A	DWG NO.	QC5631	VERSION	C