

CUSTOMER DRAWING

REV.	DESCRIPTION	APPVL. BY	DATE	ECN NO.
A	RELEASE	Emily Suen	10/07/12	
B				
C				

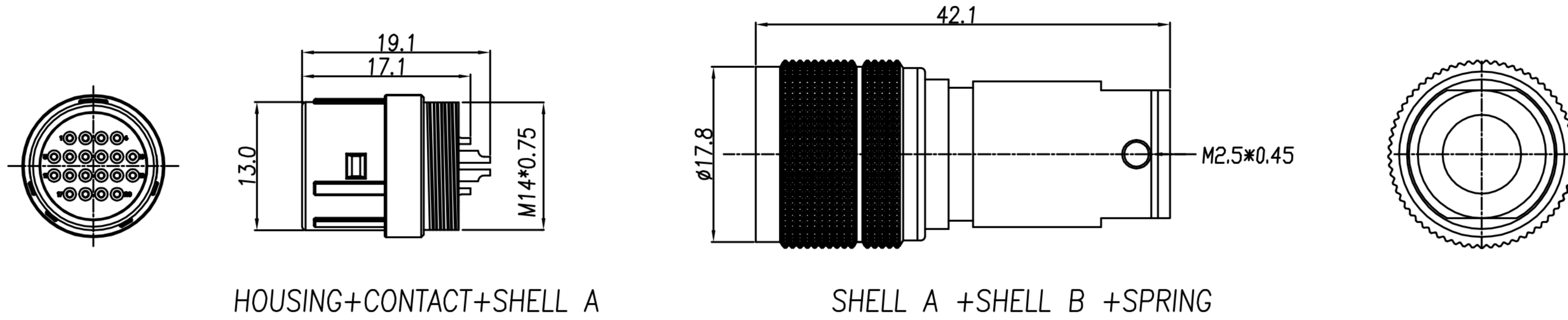

HOUSING+CONTACT+SHELL A

SHELL A +SHELL B +SPRING

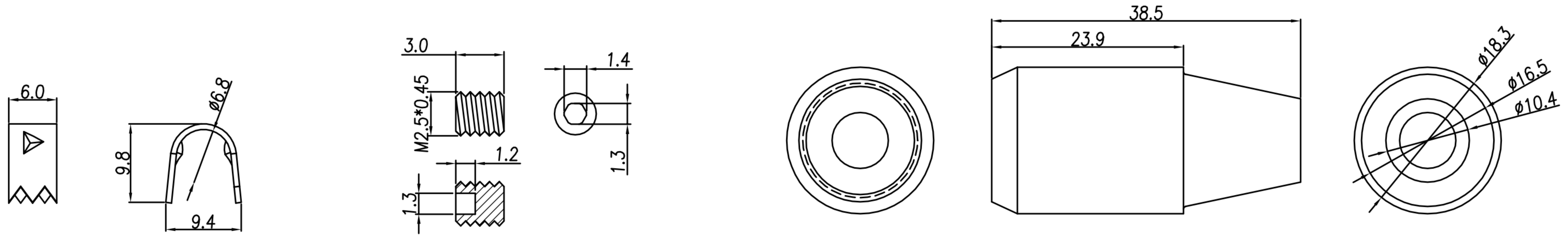

CLAMP

SCREW

SR

DRAW	Lai Angus	APPVL	Emily Suen	UNIT	mm	TOLERANCE .x ±0.20 .xx ±0.15 .xxx ±0.05 .xxxx ±0.03 ANGULA ±1°		广东科斯达电子科技有限公司 GUANG DONG KE SI DA ELECTRONIC TECHNOLOGY CO., LTD.	TITLE	DIN 20PIN(F) PLUG 连接器(SHELL SIZE 13mm)			SHEET	2/2
CHECK	Emily Suen			SCALE	1:1				PART NO.	DI-20F2-01	DWG NO.	QC5834	VERSION	A

CUSTOMER DRAWING

REV.	DESCRIPTION	APPVL. BY	DATE	ECN NO.
A	RELEASE	Emily Suen	10/07/12"	
B				
C				

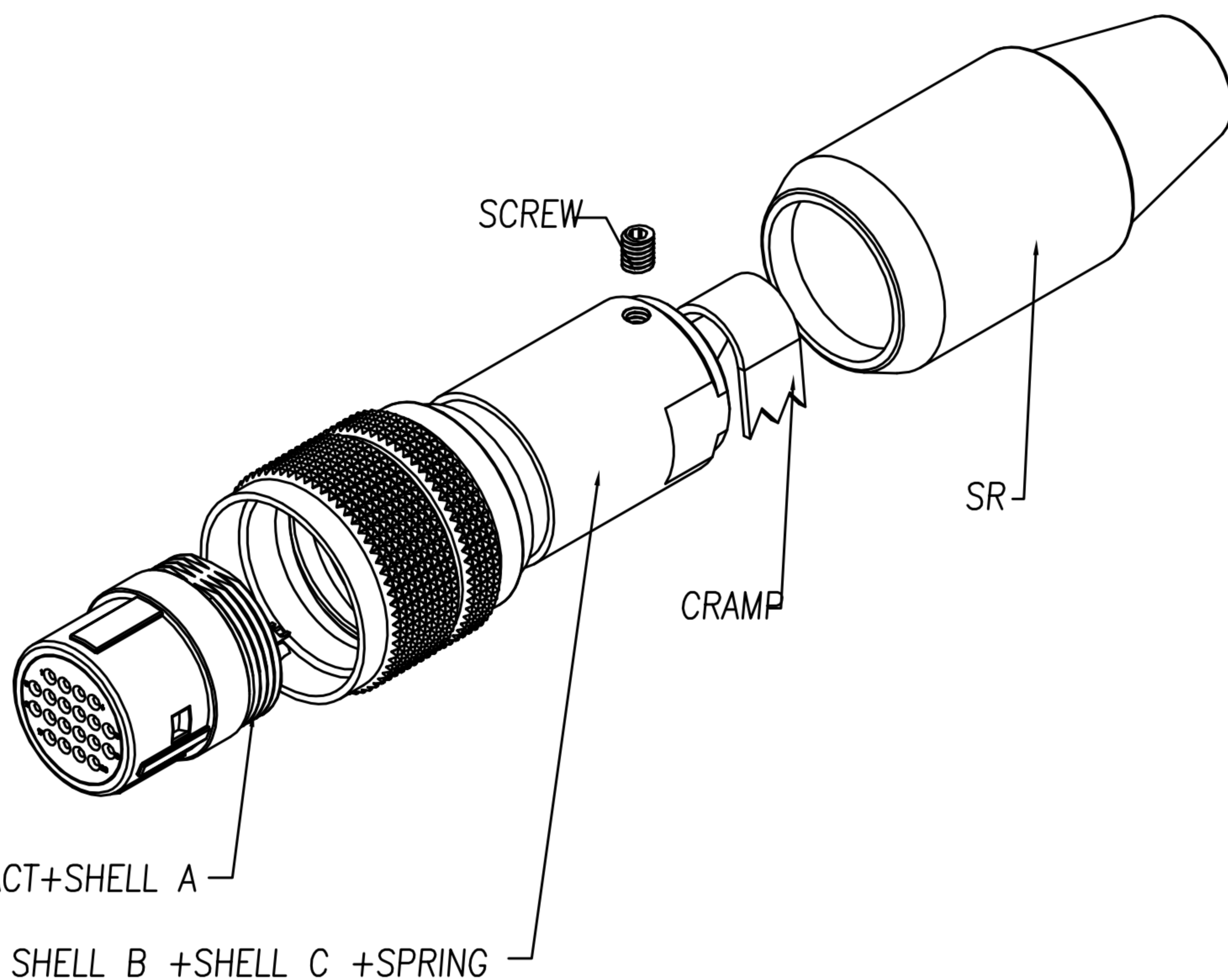
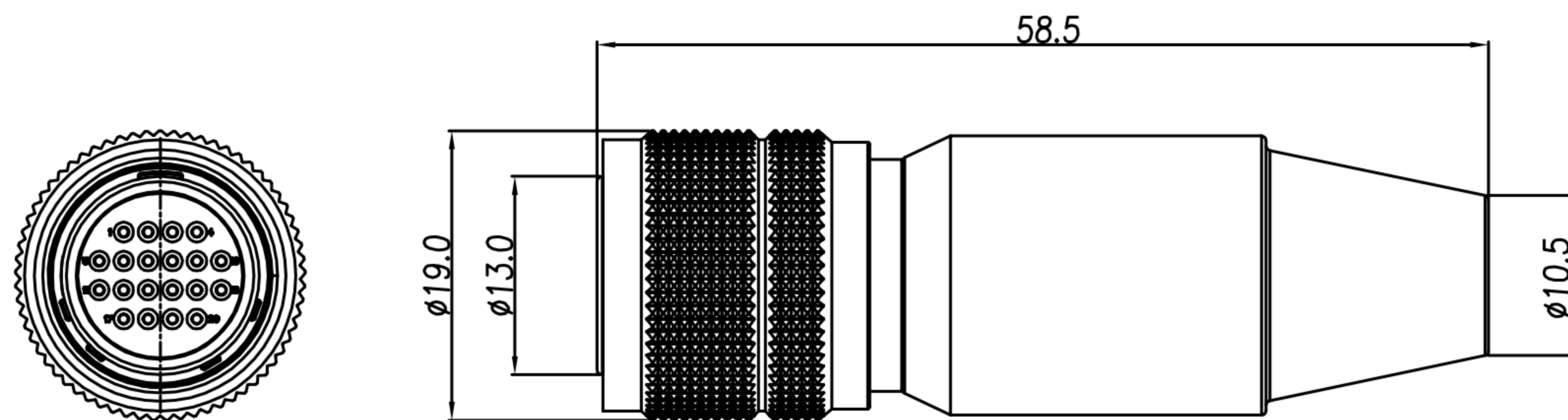

1. MATERIAL :

- 1-1. HOUSING : NYLON46 UL94V-0 ; COLOR : BLACK
- 1-2. CONTACT : BRASS
- 1-3. SHELL A : ZINC ALLOY
- 1-4. SHELL B : BRASS
- 1-5. SHELL C : BRASS
- 1-6. SPRING : STAINLESS STEEL
- 1-7. SCREW : ALLOY STEEL
- 1-8. CRAMP : BRASS
- 1-9. SR : NBR ; COLOR : BLACK

2. FINISH :

- 2-1. CONTACT : GOLD FLASH
- 2-2. SHELL A : NICKEL
- 2-3. SHELL B : SATIN NICKEL
- 2-4. SHELL C : NICKEL
- 2-5. SPRING : NICKEL
- 2-6. SCREW : NICKEL

3. ELECTRICAL SPECIFICATION :

- 3-1. Rated current : 2A
- 3-2. Rated voltage : 100V AC / 140V DC

4. Environmental :

- 4-1. Operation Temperature : -25℃~85℃

DRAW	Lai Angus	APPVL	Emily Suen	UNIT	mm	TOLERANCE			TITLE	DIN 20PIN(F) PLUG (SHELL SIZE 13mm)			SHEET
CHECK	Emily Suen			SCALE	1:1	.x ±0.20 .xx ±0.15 .xxx ±0.05 .xxxx ±0.03 ANGULA ±1°			PART NO.	DI-20F2-01	DWG NO.	QC5834	VERSION