

A		B		C		D		E		F	
1	CUSTOMER DRAWING										
REV.	DESCRIPTION		APPVL. BY	DATE	ECN NO.						
△A	RELEASE		LED	18/07/22'							
△B											
△C											

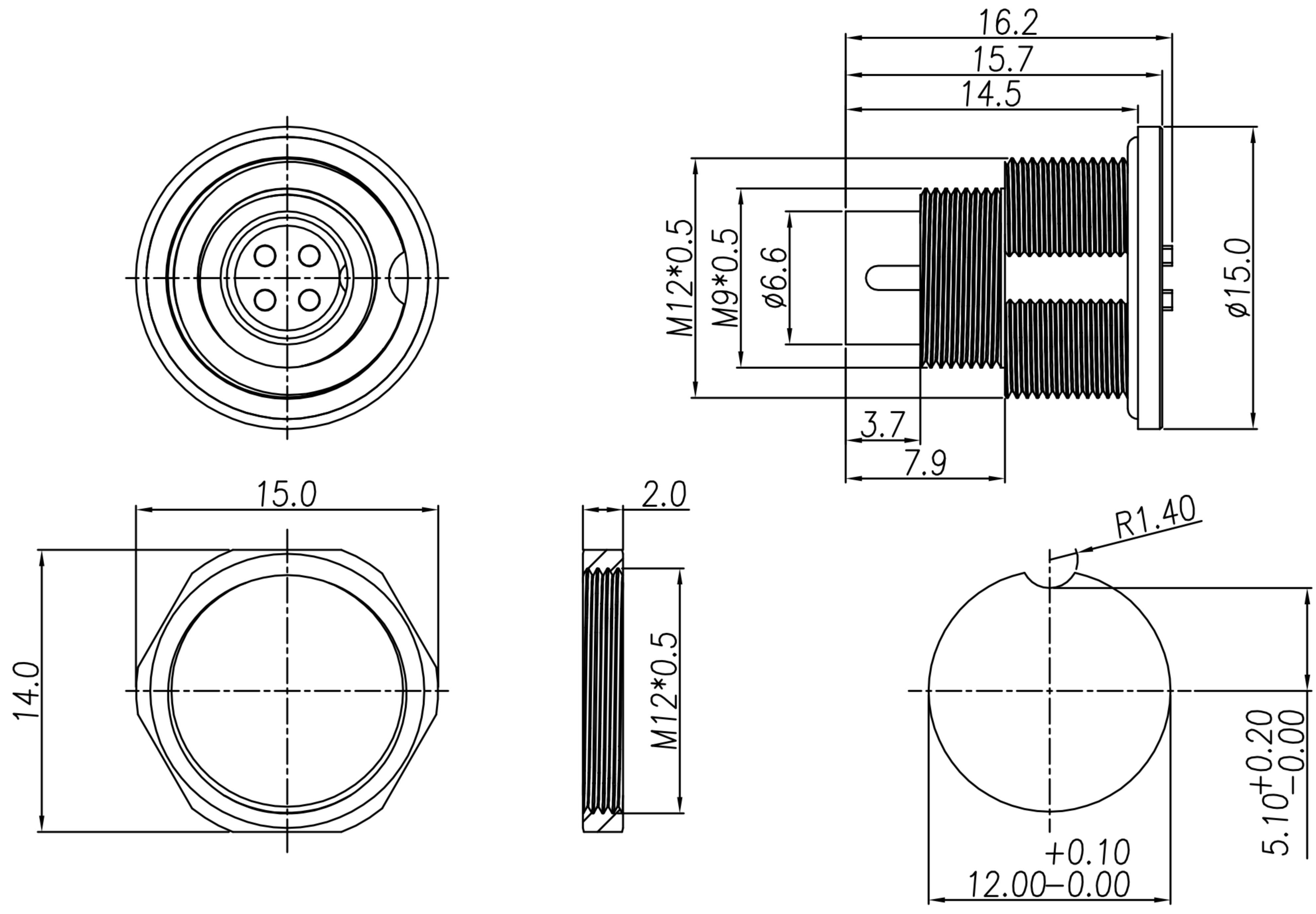

NUT

RECOMMEND PANEL CUT-OUT

- MATERIAL :
 - 1-1. HOUSING : PA UL94V-0 ; COLOR : BLACK
 - 1-2. CONTACT : BRASS.
 - 1-3. SHELL : BRASS.
 - 1-4. O-RING : EPDM ; COLOR : BLACK.
 - 1-5. NUT : BRASS
- FINISH :
 - 2-1. CONTACT : GOLD FLASH
 - 2-2. SHELL : NICKEL PLTAEED.
 - 2-3. NUT : NICKEL PLTAEED.
- ELECTRICAL SPECIFICATION :
 - 3-1. Rated current(40°C) : 2~3P 4A; 4~5P 3A; 7~8P 1A
 - 3-2. Rated Voltage : 125V
 - 3-3. Water proof : IP67
- Environmental :
 - 4-1. Operation Temperature : -40°C~85°C

WP-02M2-87-11	WP-03M2-141-11	WP-04M2-238-11	WP-05M2-205-11	WP-07M2-26-11	WP-08M2-128-11

DRAWN	LED	APP'D	Ku Chou	UNIT	mm	TOLERANCE		广东科斯达电子科技有限公司 GUANG DONG KE SI DA ELECTRONIC TECHNOLOGY CO., LTD.	TITLE	WP M9 (M) M12 前鎖母線式			SHEET	1
CHK'D	Ku Chou			SCALE	1:1	.x ±0.20 .xx ±0.10 .xxx ±0.05 .xxxx ±0.03 ANGULA ±1°			PART NO.	SEE TABLE A	DWG NO.	QC10463	VERSION	A