

CUSTOMER DRAWING

REV.	DESCRIPTION	APPVL. BY	DATE	ECN NO.
A	RELEASE	Fido Weng	10/01/13'	
B				
C				

NOTE:

- MATERIAL :
 - HOUSING : PBT UL94V-0 ; COLOR : BLACK
 - CONTACT : BRASS.
 - SHELL : BRASS.
 - NUT : BRASS.
 - O-RING : EPDM ; COLOR : BLACK
- FINISH :
 - CONTACT : SEE TABLE A
 - SHELL : NICKEL PLATED.
 - NUT : NICKEL PLATED.
- ELECTRICAL SPECIFICATION :
 - Rated current : 4A
 - Rated voltage : 60V
 - Water proof : IP67
- Environmental :
 - Operation Temperature : -20°C~85°C

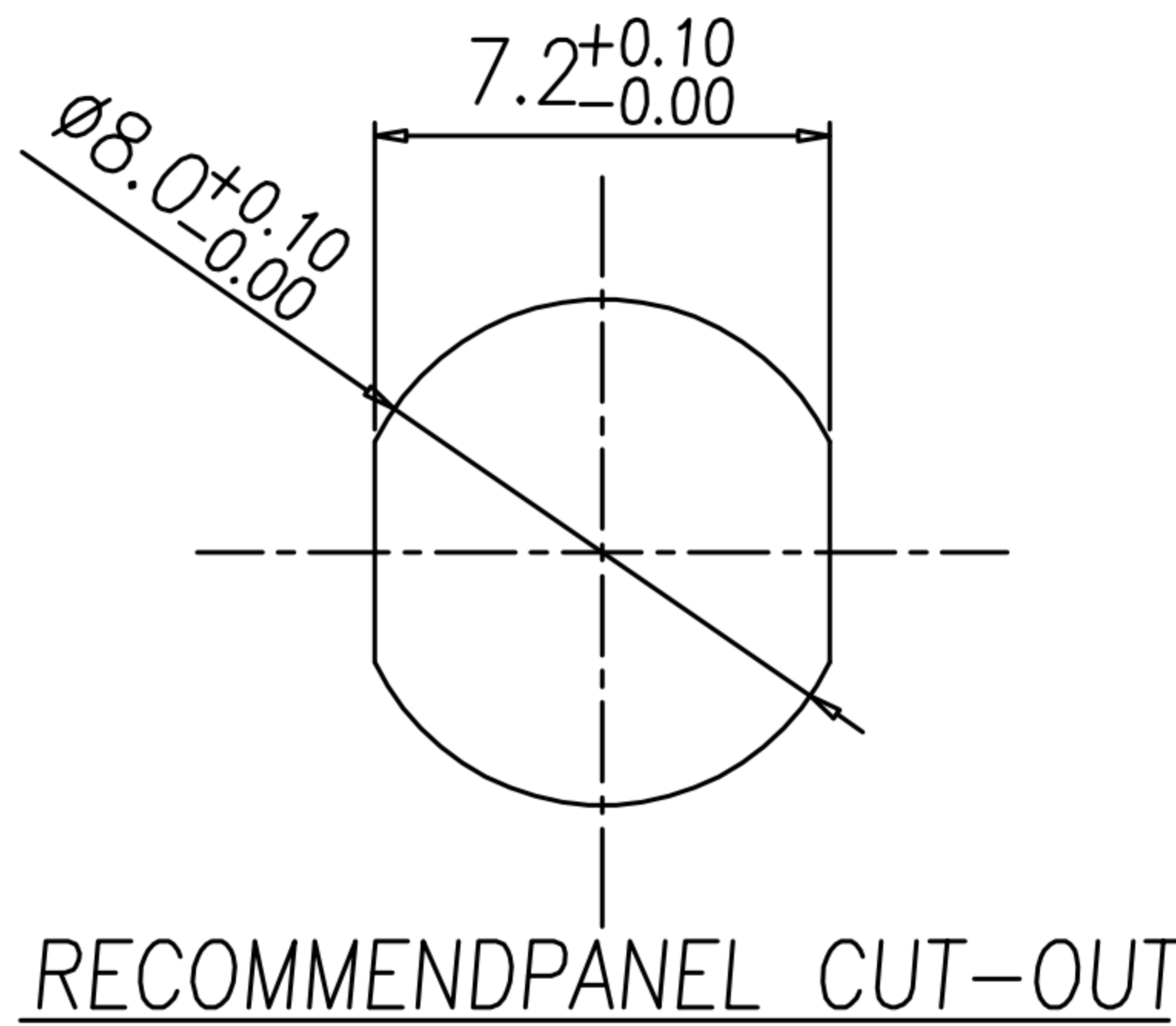
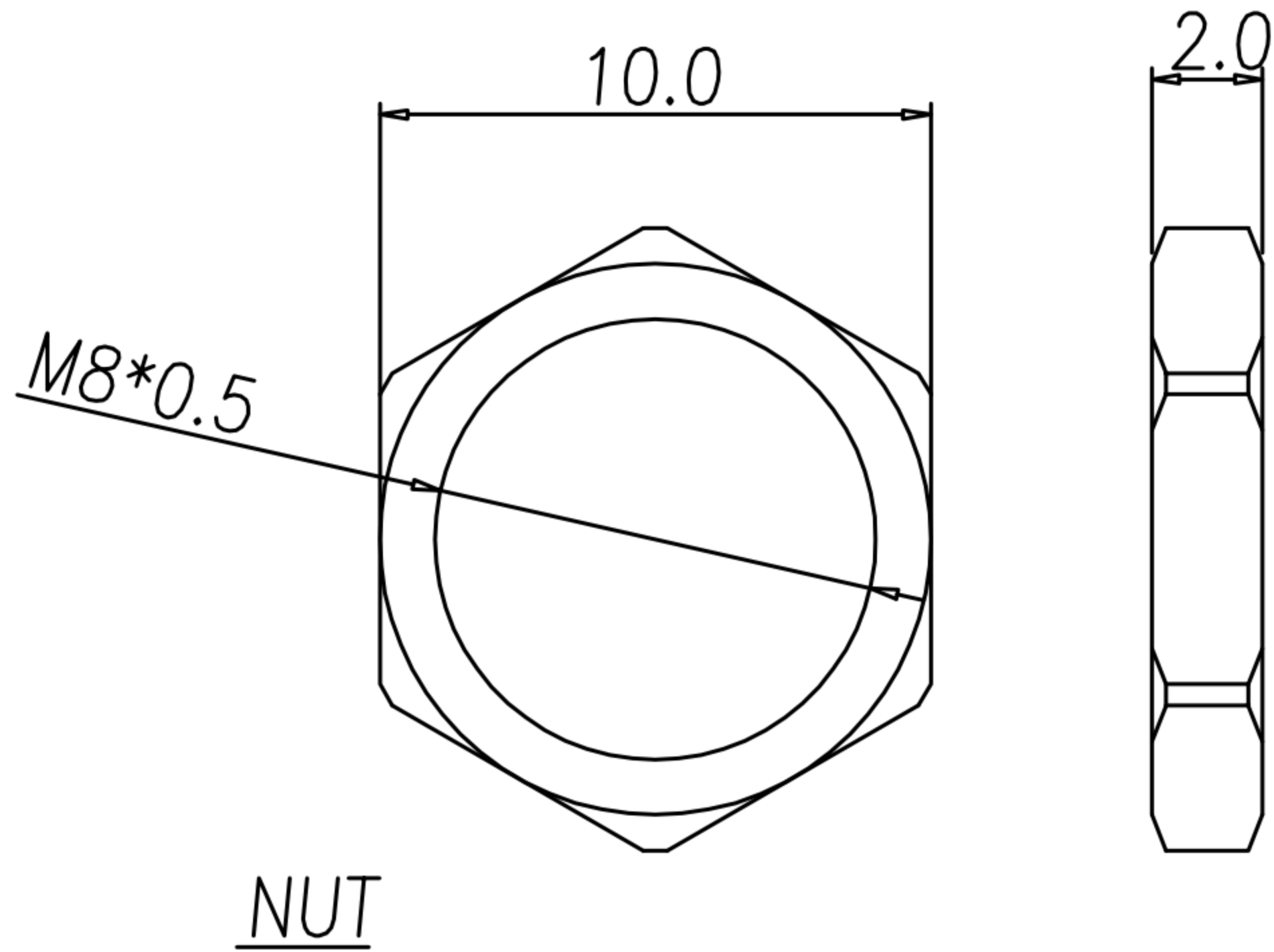
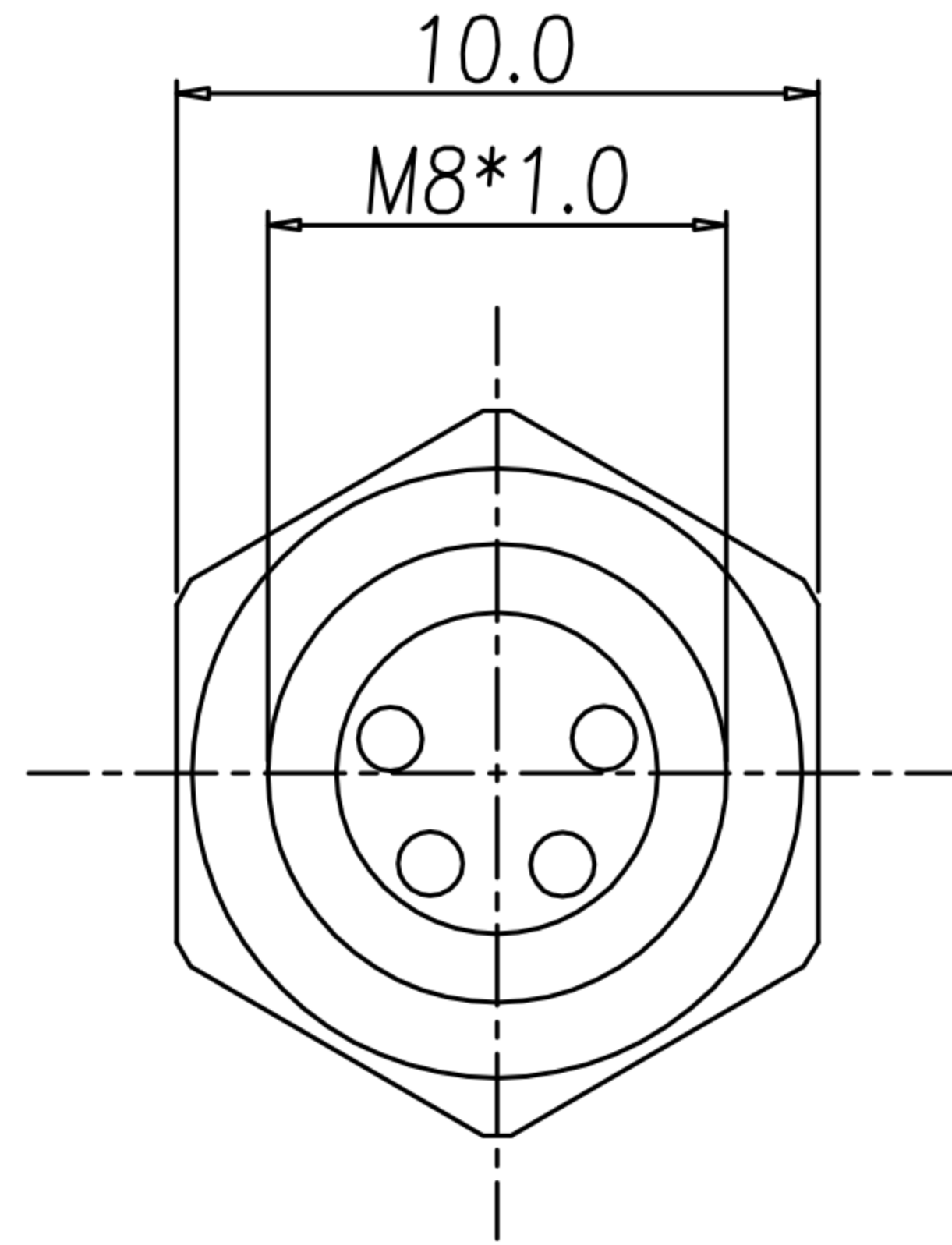
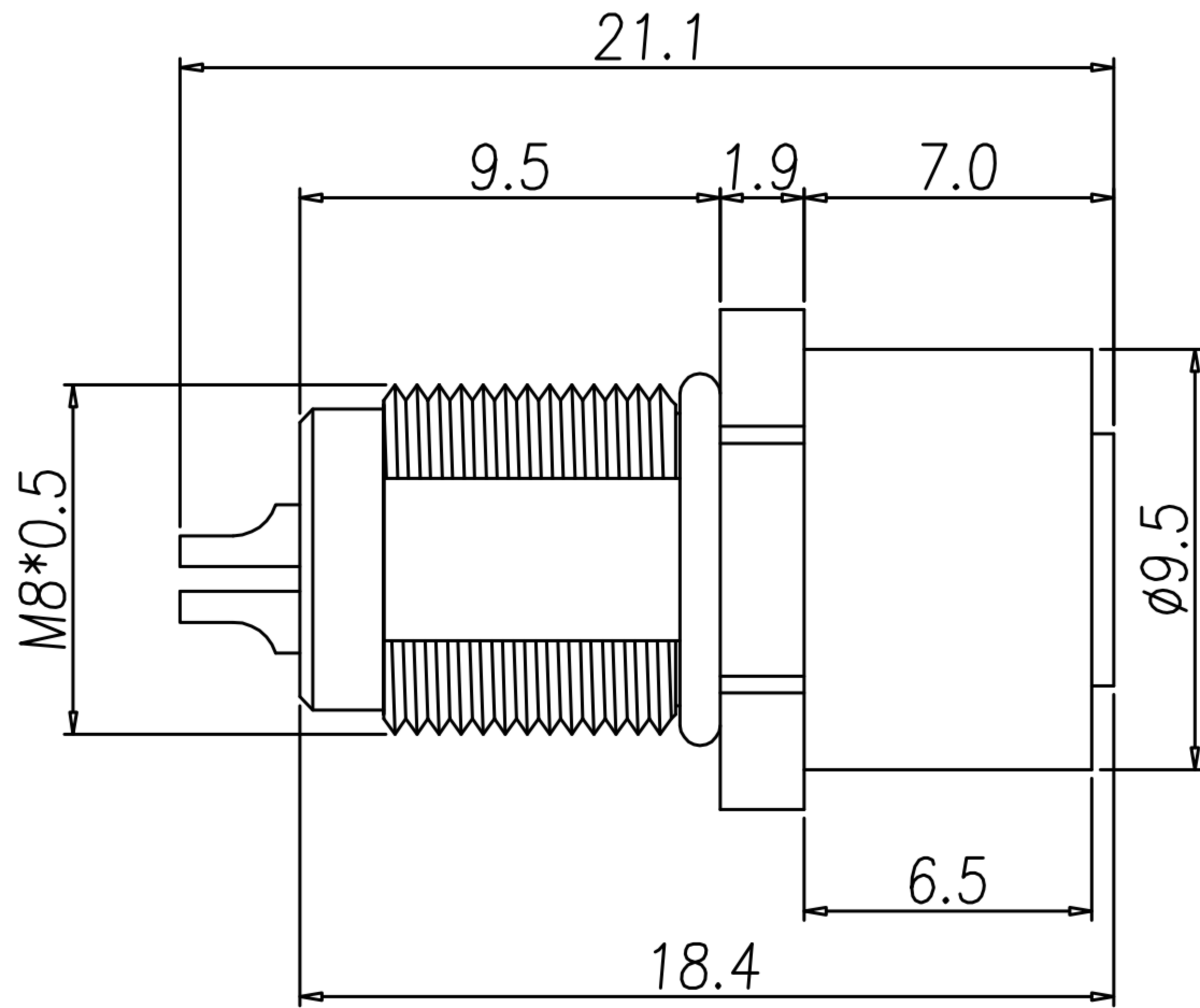

TABLE A

4PIN	3PIN	2PIN	
WP-04F2-135-11 WP-04F2-102	WP-03F2-63-11 WP-03F2-35	WP-02F2-39-11 WP-02F2-22	
WP-04F2-135-11	GOLD 10u"		
WP-04F2-102	GOLD FLASH		
WP-03F2-63-11	GOLD 10u"		
WP-03F2-35	GOLD FLASH		
WP-02F2-39-11	GOLD 10u"		
WP-02F2-22	GOLD FLASH		
P/N	FINISH		

DRAW	Mark Kao	APPVL	Ku Chou	UNIT	mm	TOLERANCE		广东科斯达电子科技有限公司 GUANG DONG KE SI DA ELECTRONIC TECHNOLOGY CO., LTD.	TITLE	防水頭 M8 (F) 後鎖焊線式			SHEET	1
CHECK	Emily Suen			SCALE	1:1	.x ±0.20 .xx ±0.10 .xxx ±0.05 .xxxx ±0.03 ANGULA ±1°			PART NO.	SEE TABLE A	DWG NO.	QC6054	VERSION	A