

CUSTOMER DRAWING

REV.	DESCRIPTION	APPROVED BY	DATE	ECN NO.
A	RELEASE	Emily Suen	05/08/11'	
B	CHANGE MATERIAL	Emily Suen	16/09/22'	
C				
D				

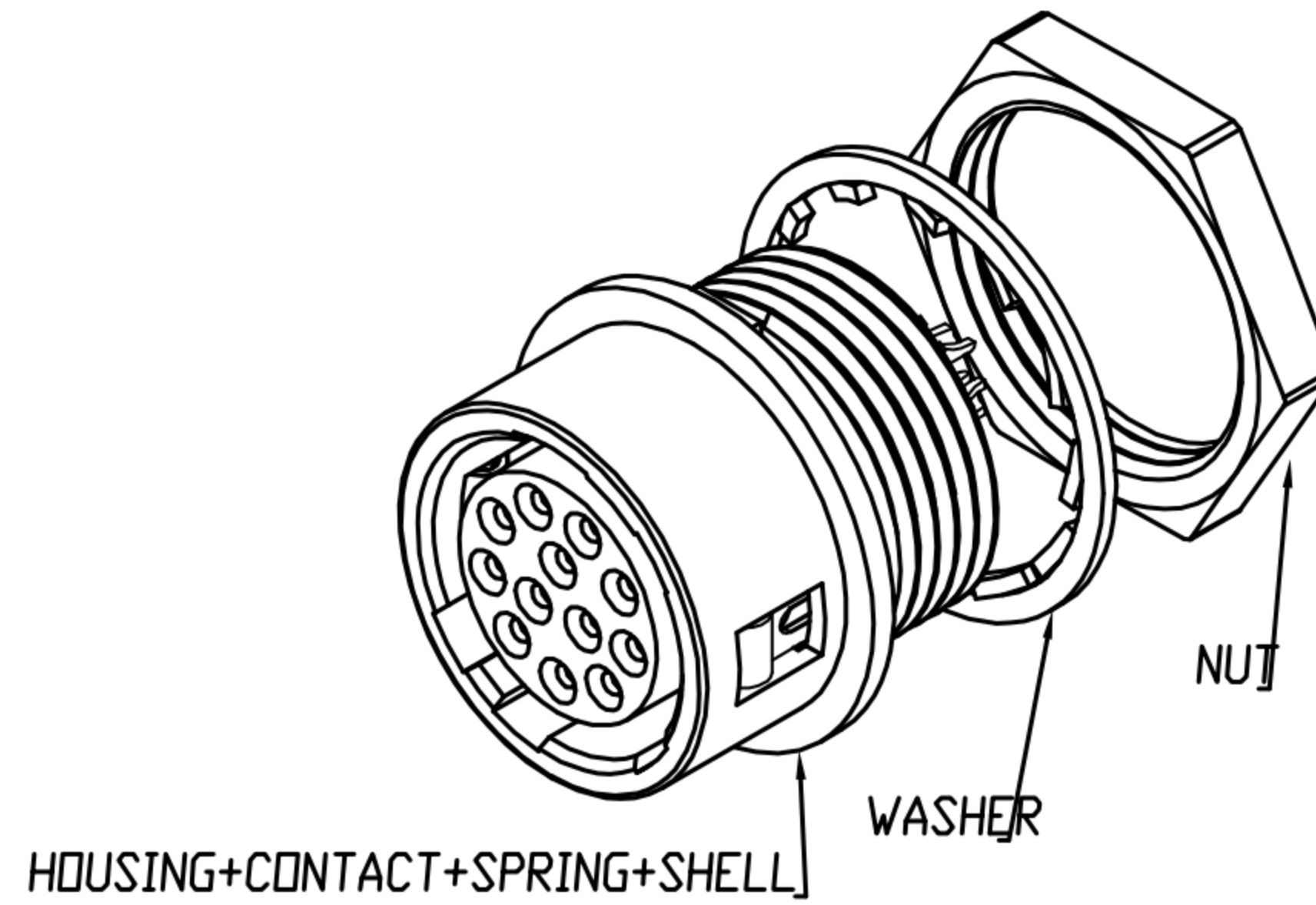
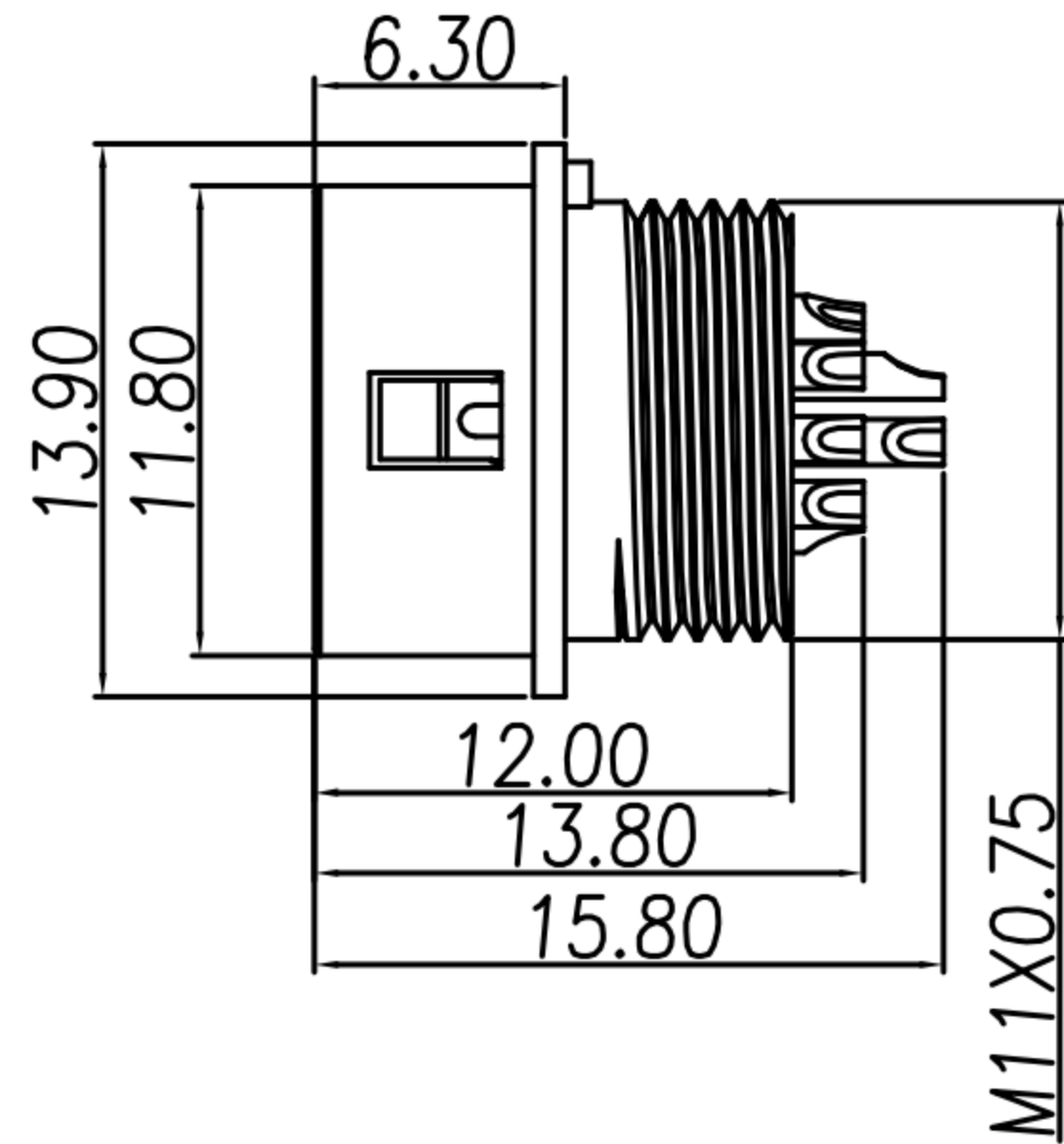
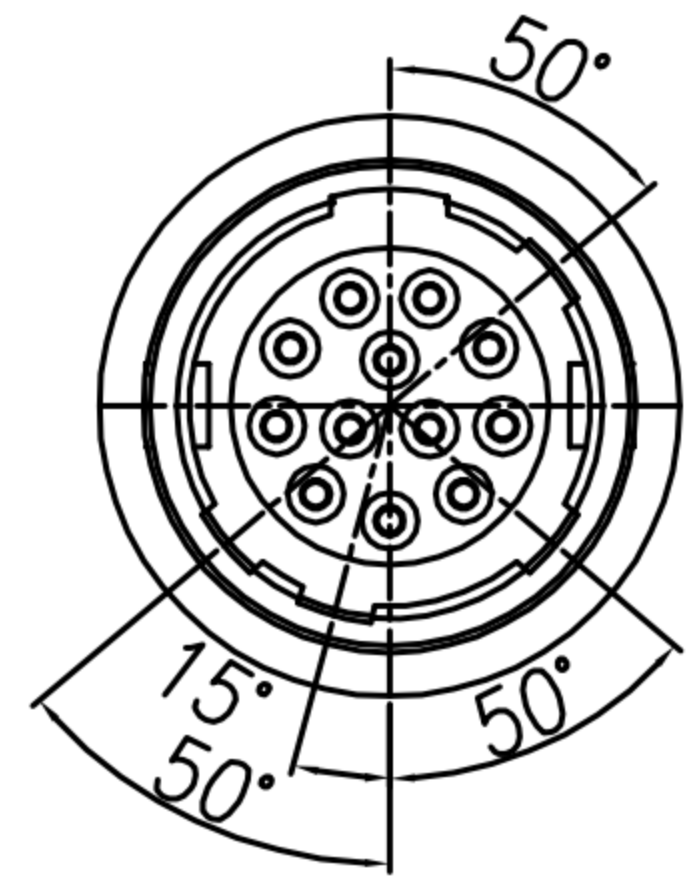

NOTE:

- MATERIAL :
  - 1-1. HOUSING : NYLON66 UL94V-0; COLOR : BLACK
  - 1-2. CONTACT : BRASS
  - 1-3. SHELL : ZINC ALLOY
  - 1-4. SPRING : STAINLESS STEEL
  - 1-5. WASHER : PHOSPHOR BRONZE
  - 1-6. NUT : BRASS
- FINISH :
  - 2-1. CONTACT : GOLD FLASH
  - 2-2. SHELL : NICKEL
  - 2-3. WASHER : NICKEL
  - 2-4. NUT : NICKEL
- ELECTRICAL SPECIFICATION :
  - 3-1. Rated current : 2A
  - 3-2. Rated voltage : 100V AC / 140V DC
- Environmental :
  - 4-1. Operation Temperature : -25°C~85°C

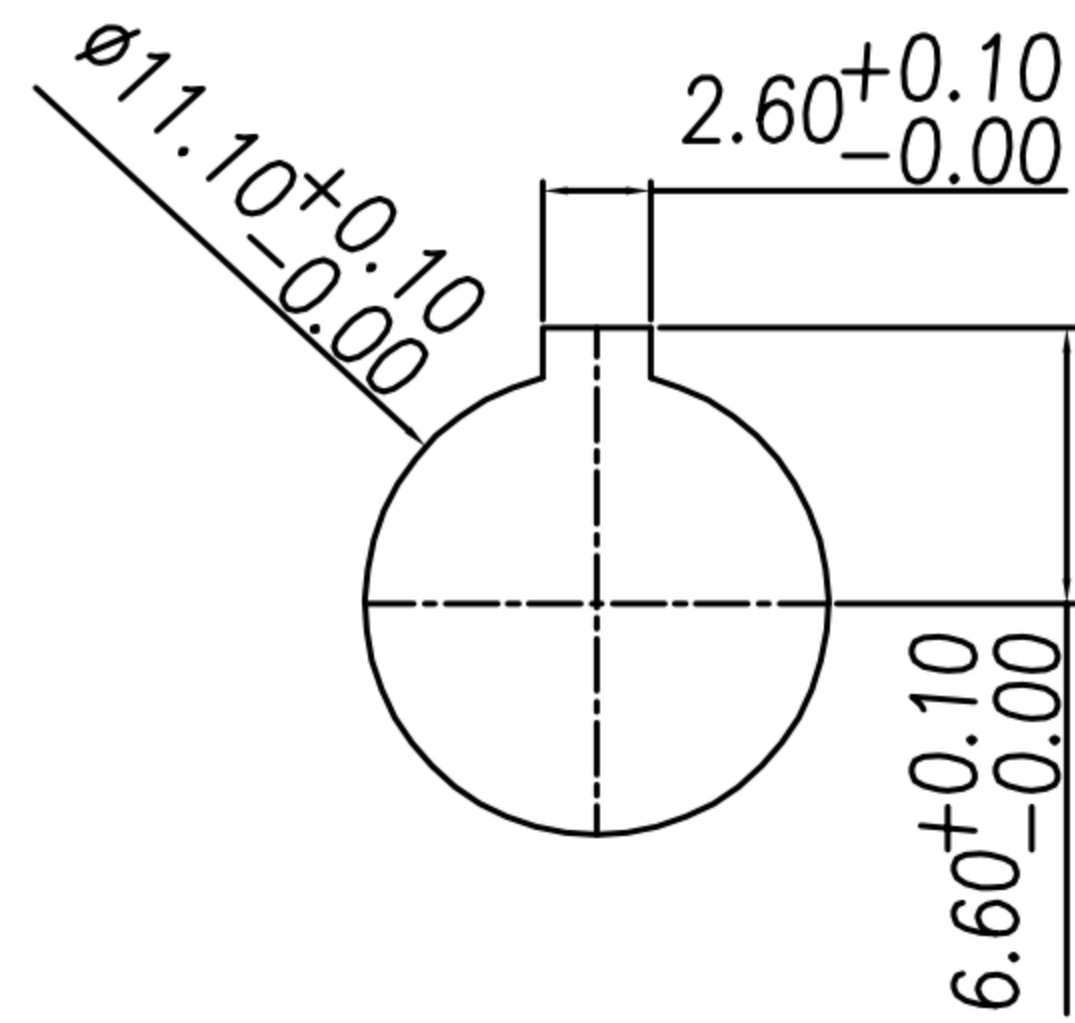

RECOMMENDED MOUNTING HOLE

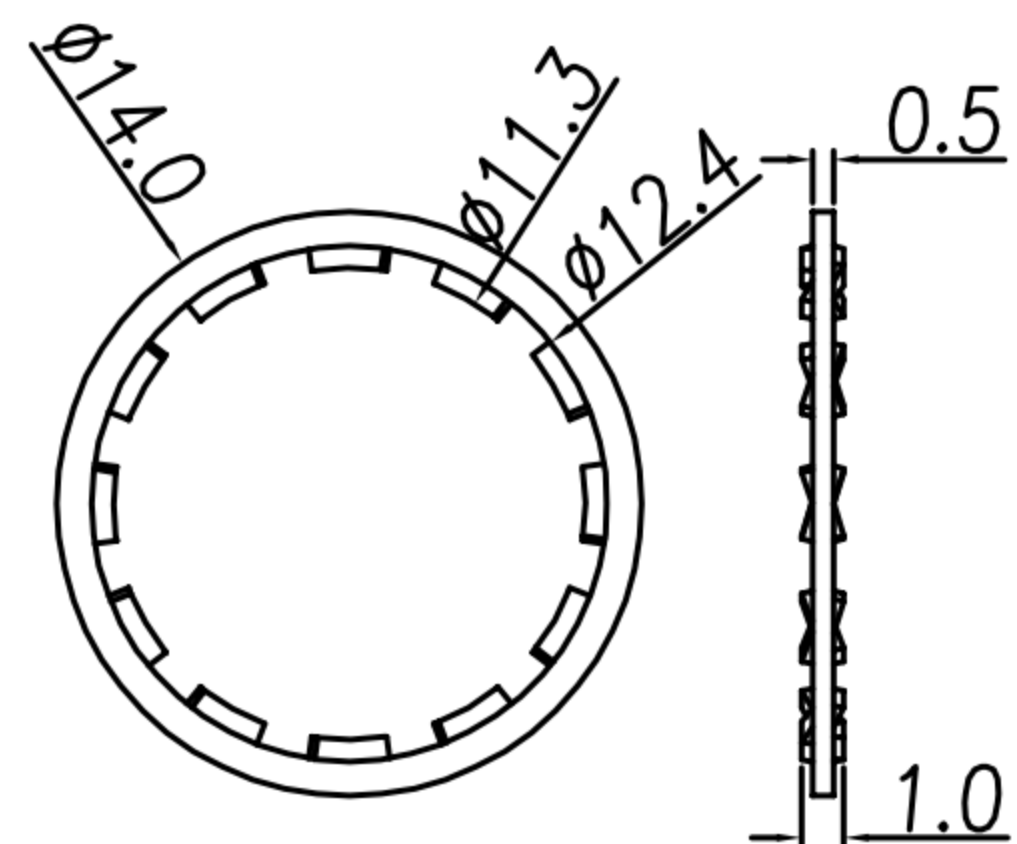

WASHER

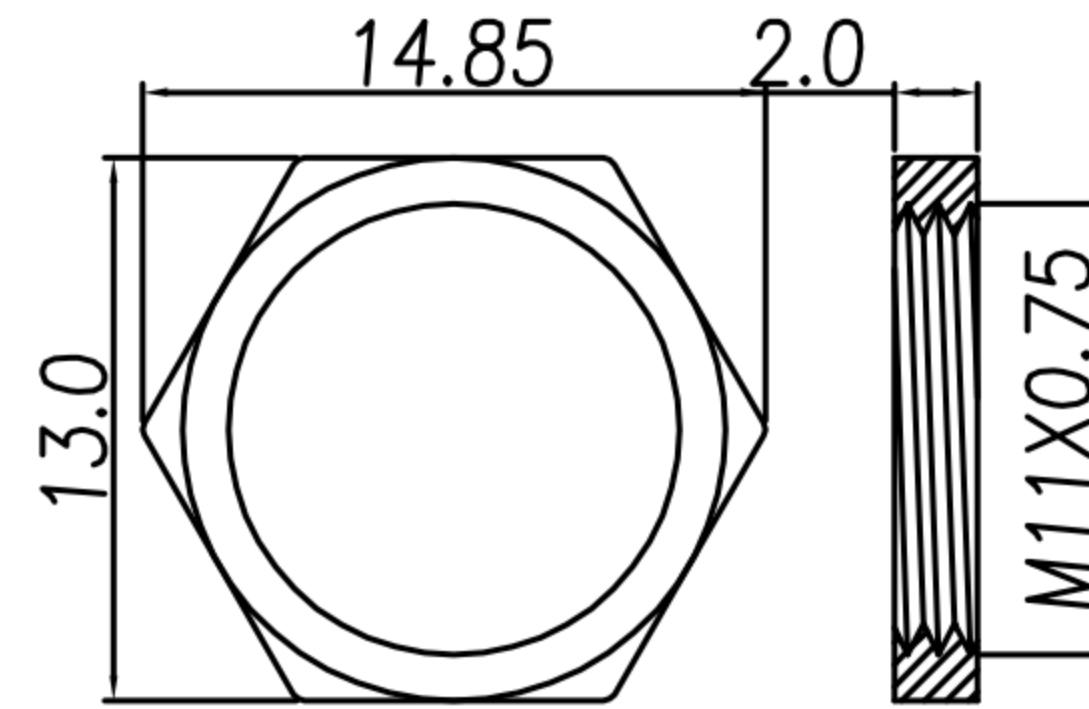

NUT

TABLE A

CONTACT ARRANGEMENT & DIMENSIONS(FRONT VIEW)	
DI-12F2-02	DI-10F2-03

DRAWN	Ku Chou	APPV'L	Emily Suen	UNIT	mm	TOLERANCE			TITLE	DIN (F) 焊線式 (SHELL TYPE: RECEPTACLE)			SHEET
CHK'D	Emily Suen			SCALE	1:1				PART NO.	SEE TABLE A	DWG NO.	QC5555	VERSION

1/1  
B