

CUSTOMER DRAWING

REV.	DESCRIPTION	APPVL. BY	DATE	ECN NO.
A	RELEASE	Yeh Chou	17/04/19*	
B				
C				

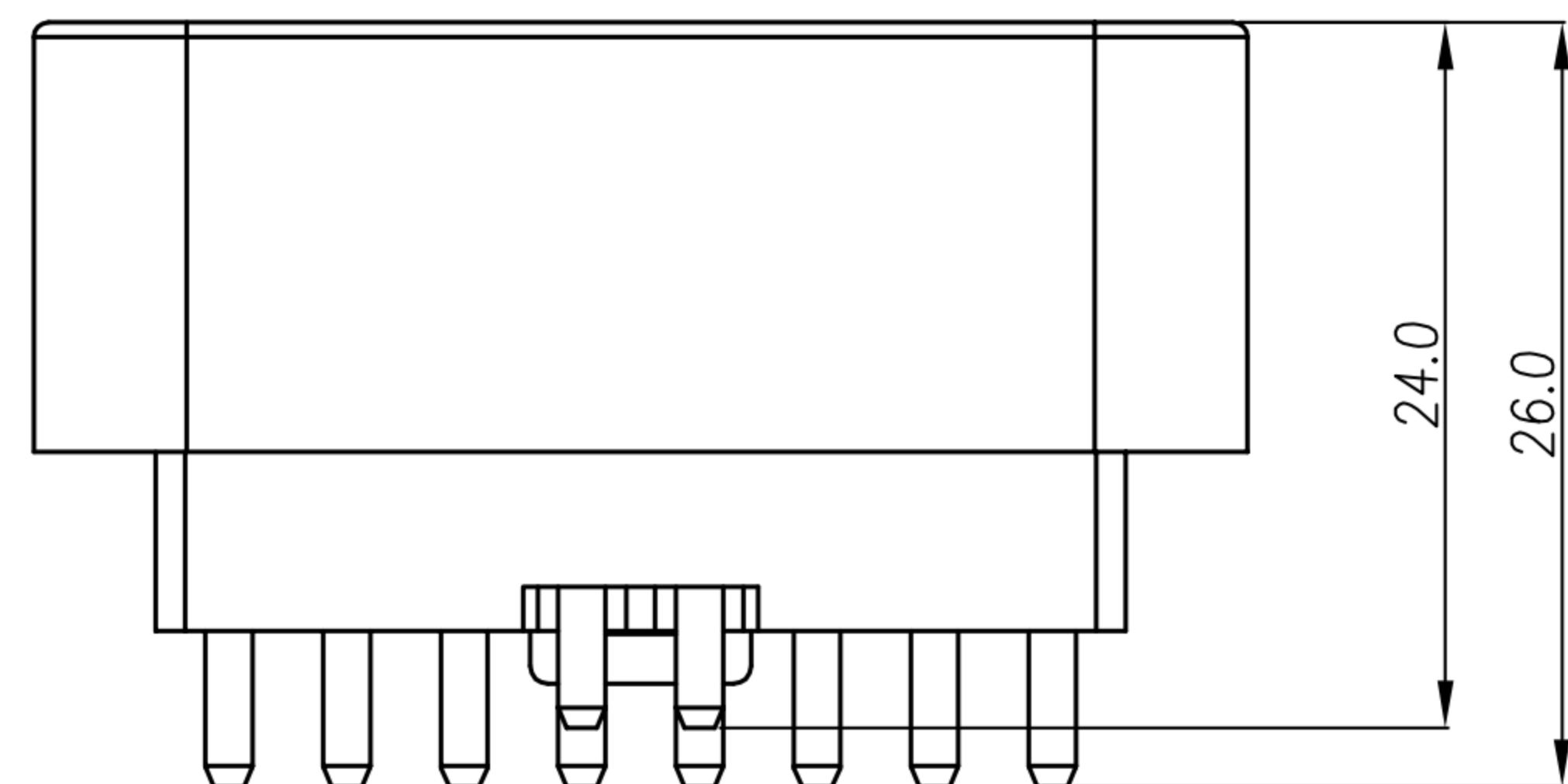
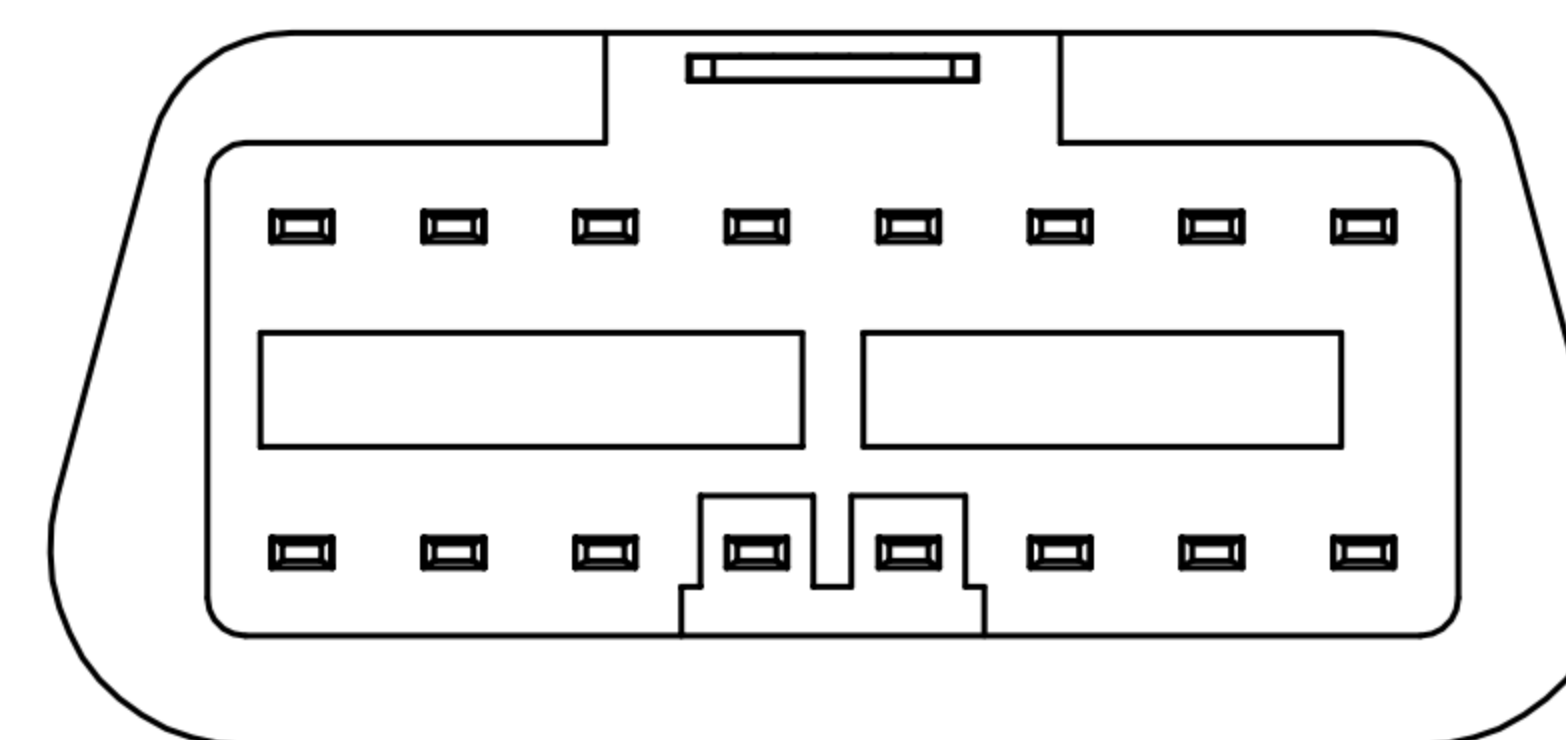
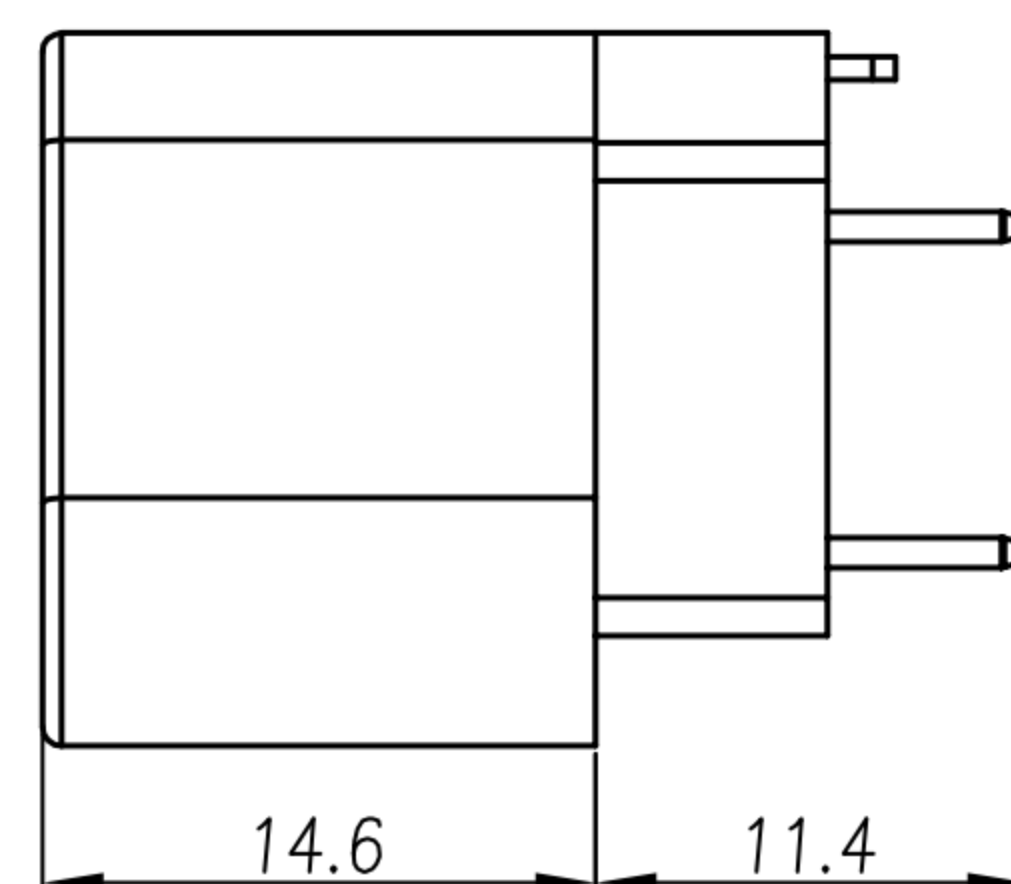
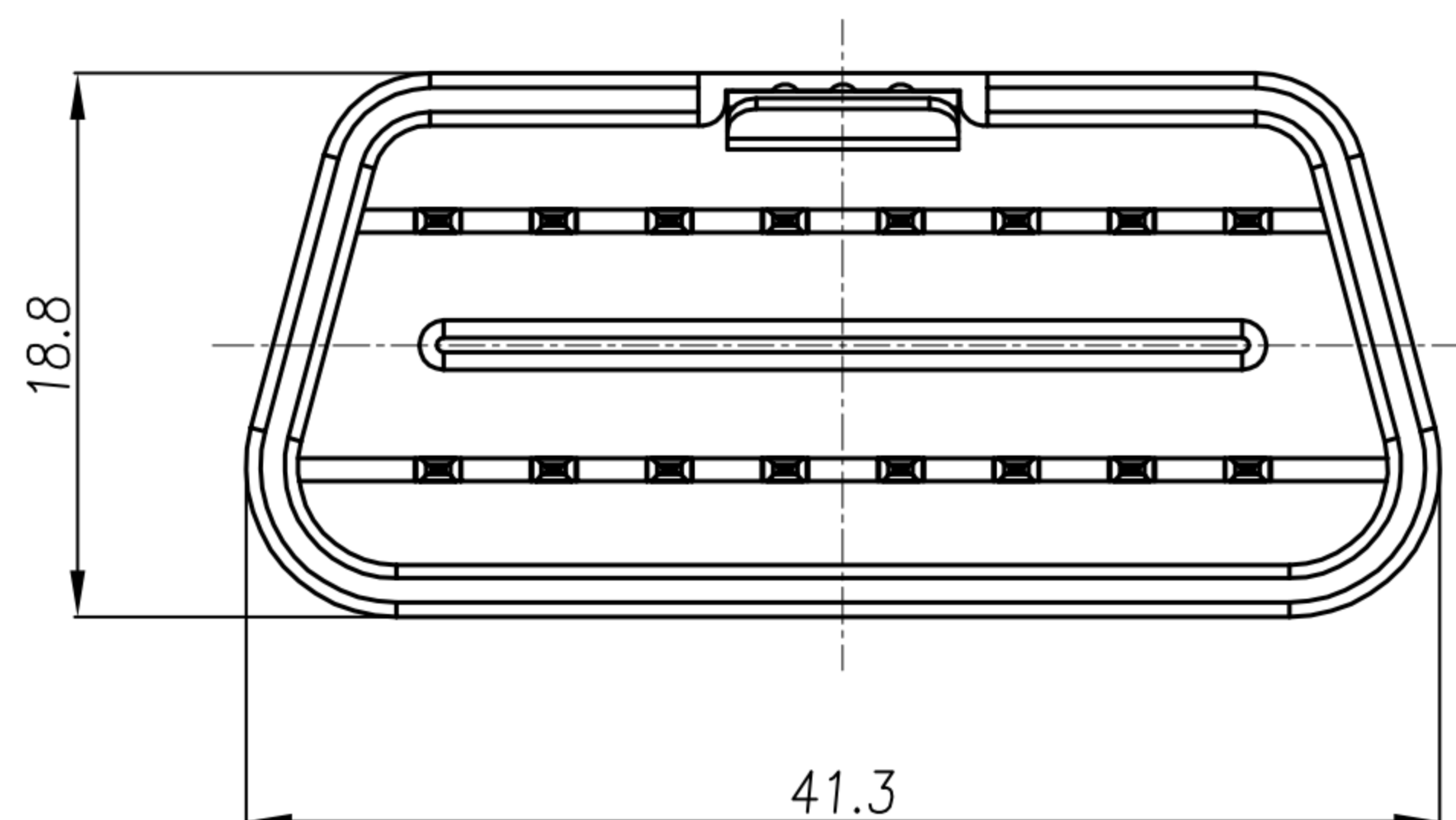
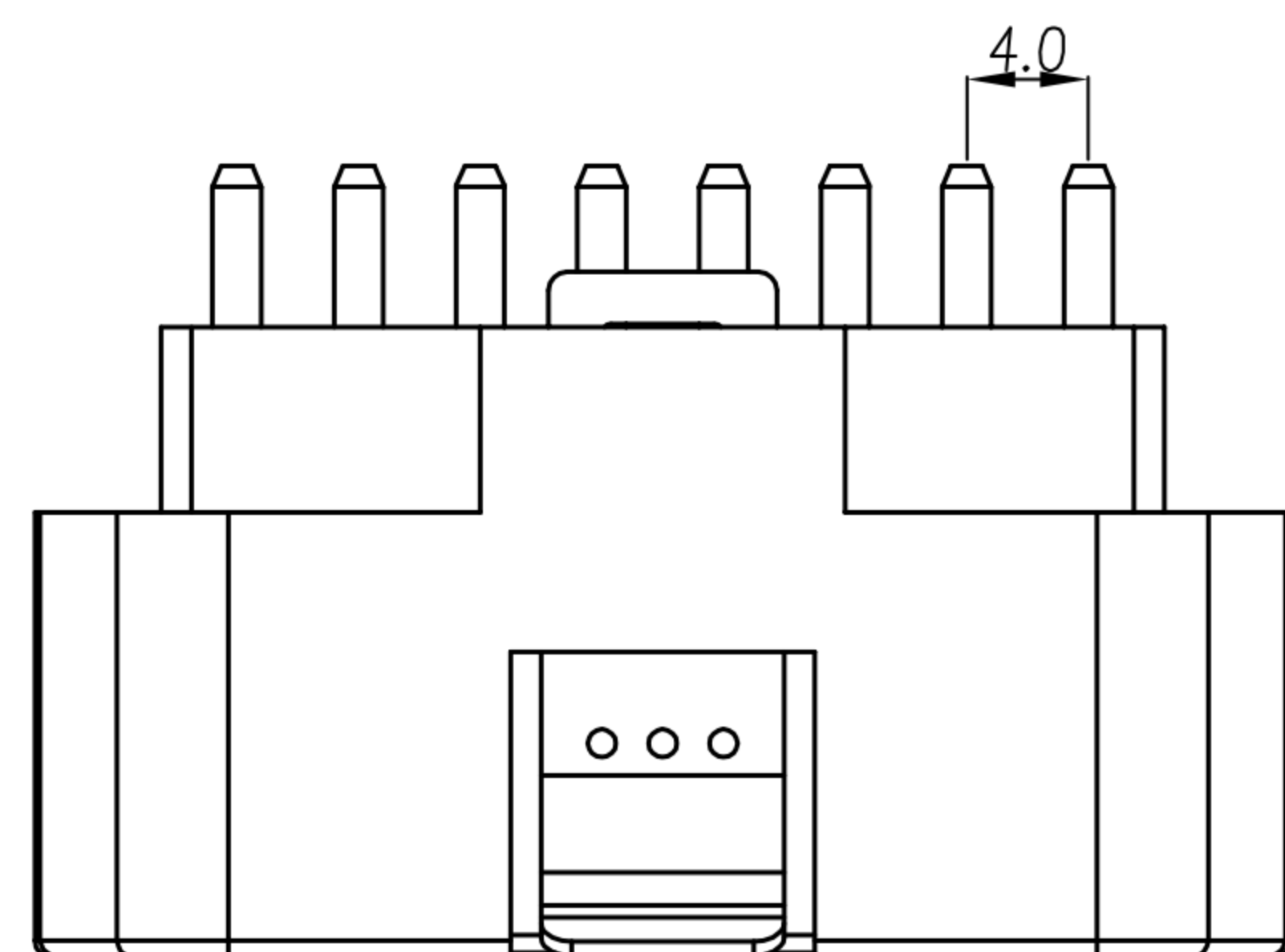

1. MATERIAL :
  - 1-1. HOUSING : NYLON66 ; COLOR : BLACK
  - 1-2. CONTACT : BRASS
  - 1-3. SPRING : STAINLESS STEEL
2. FINISH :
  - 2-1. CONTACT :
    - CONTACT AREA : BRIGHT TIN.
    - SOLDER AREA : TIN 60u"

DRAW	Ya Chou	APPVL	Fido Weng	UNIT	mm	TOLERANCE			TITLE	OBD2 16(M)彈片式(寬8.0) 單隔板			SHEET	1
CHECK	Emily Suen			SCALE	1:1	.x ±0.20 .xx ±0.10 .xxx ±0.05 .xxxx ±0.03 ANGULA ±1°			PART NO.	OBD2-16M1-69-01	DWG NO.	QC9063	VERSION	A