

CUSTOMER DRAWING

REV.	DESCRIPTION	APPVL. BY	DATE	ECN NO.
△A				
△B				
△C				

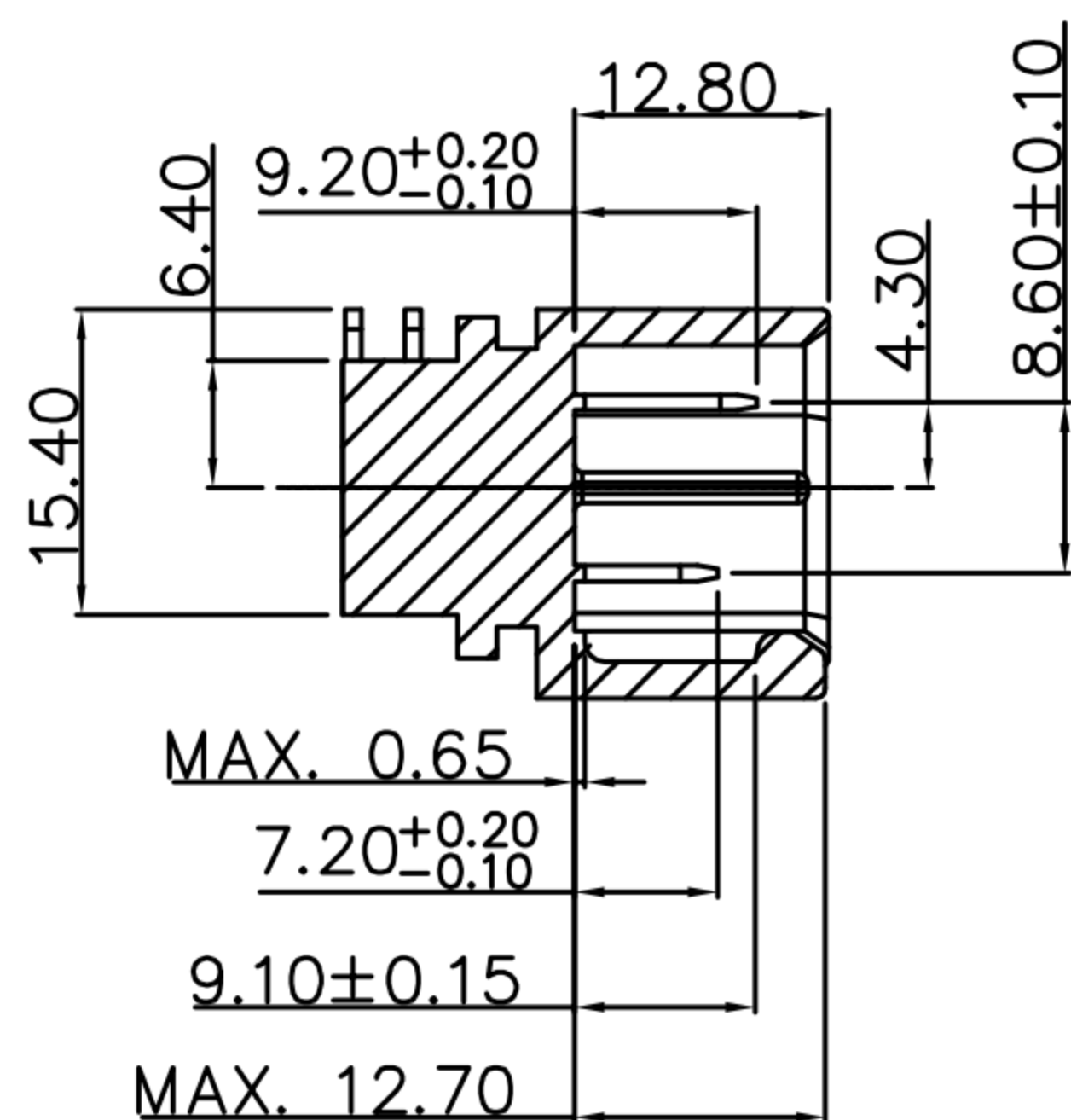

Section A-A(SCALE 1:1)

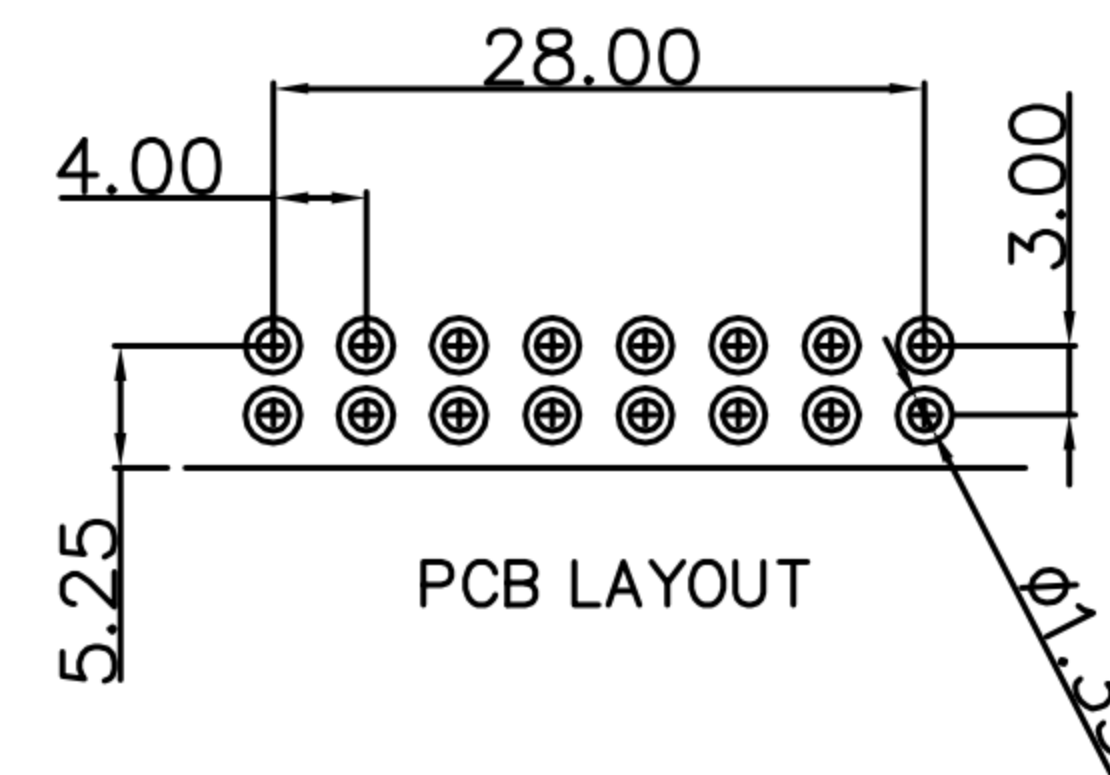
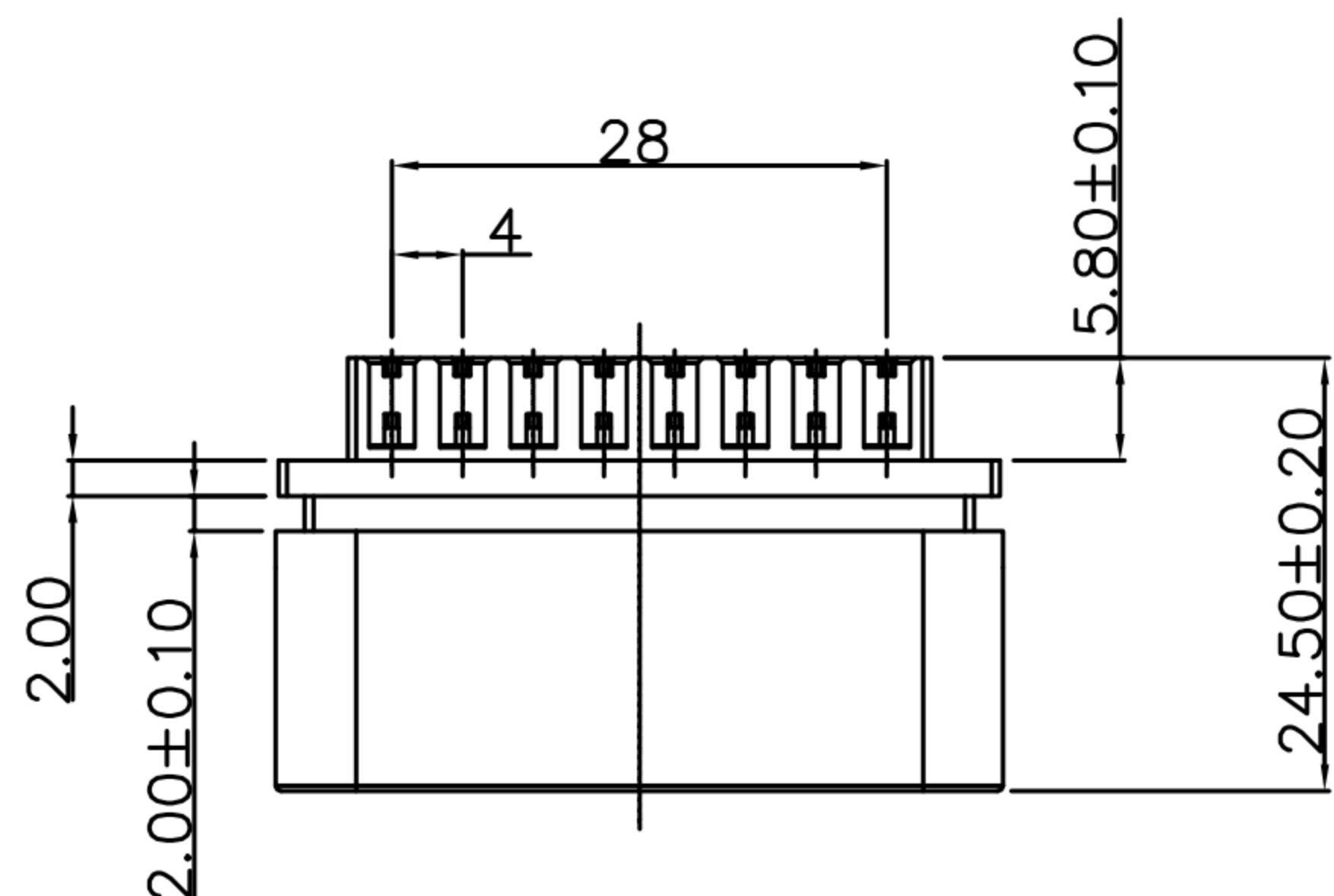
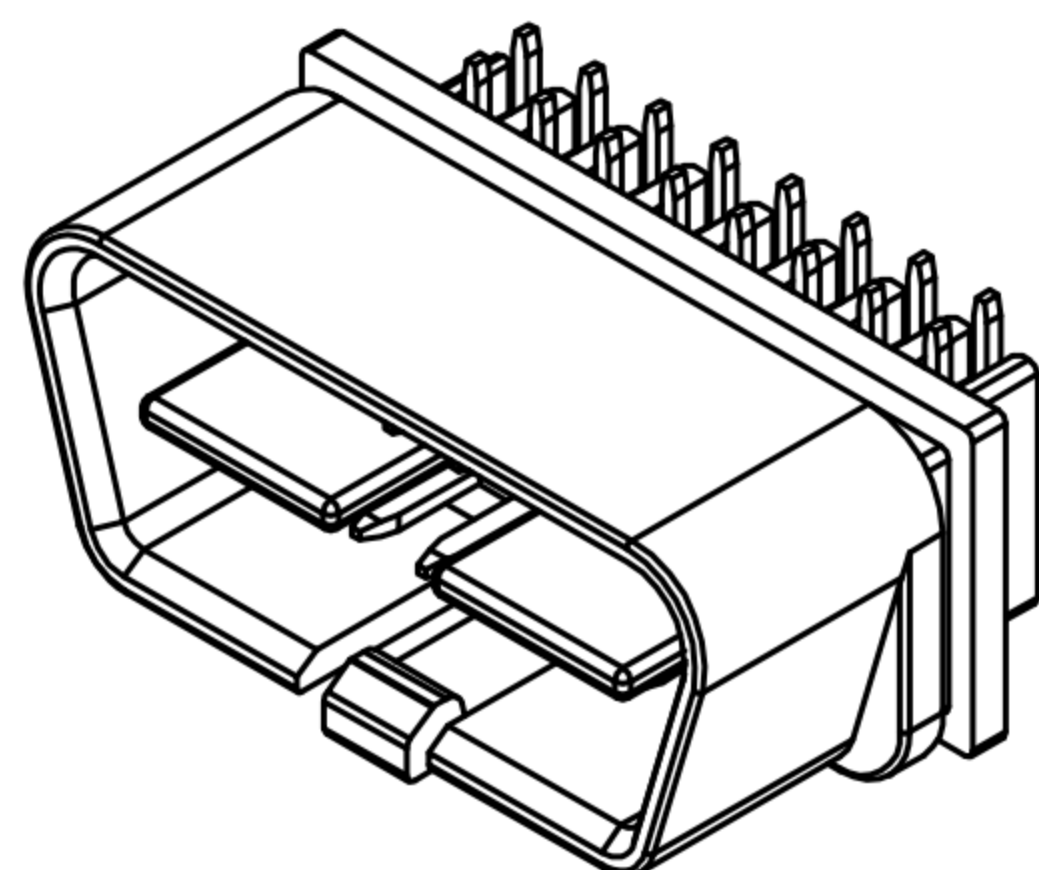
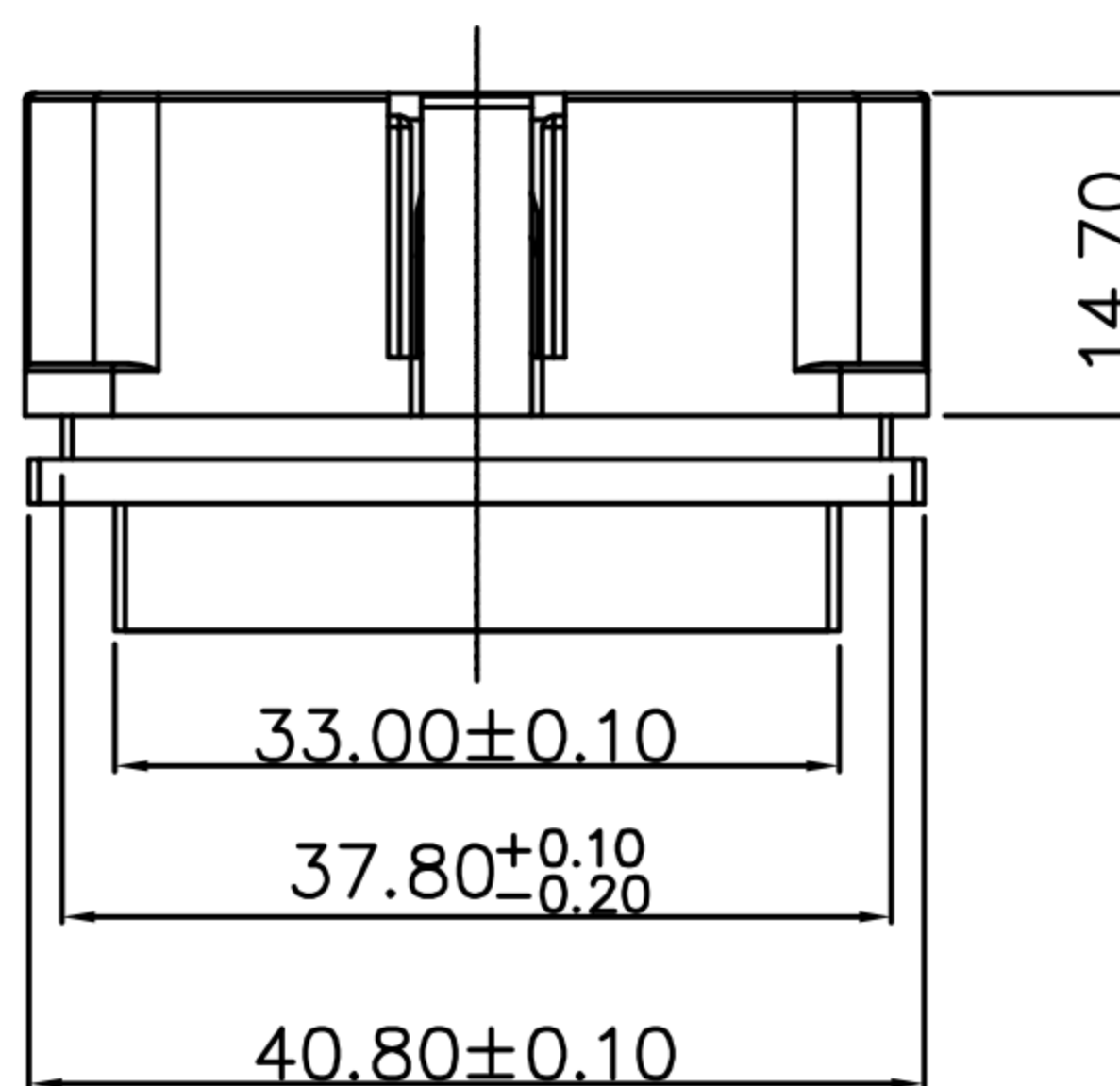
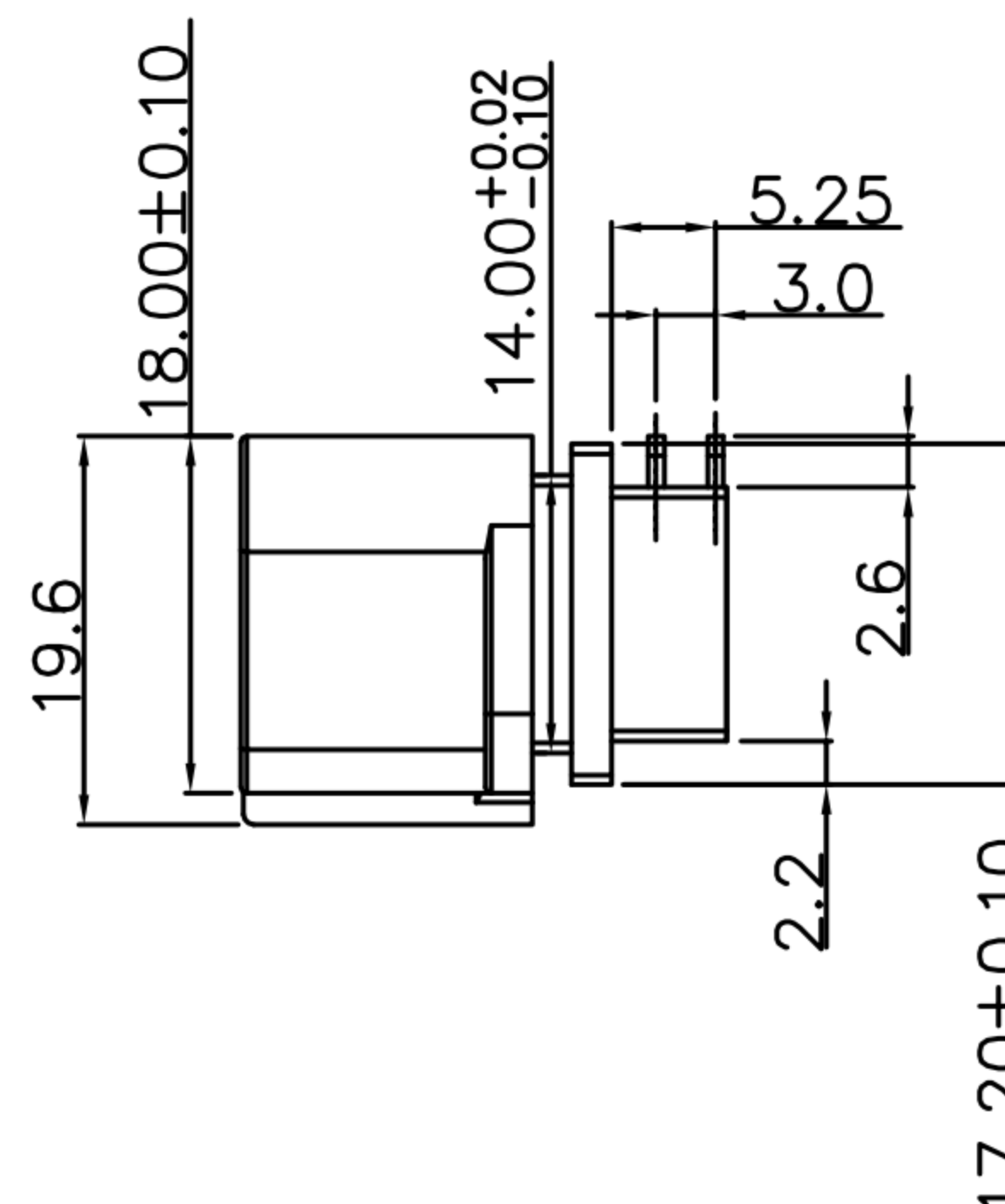
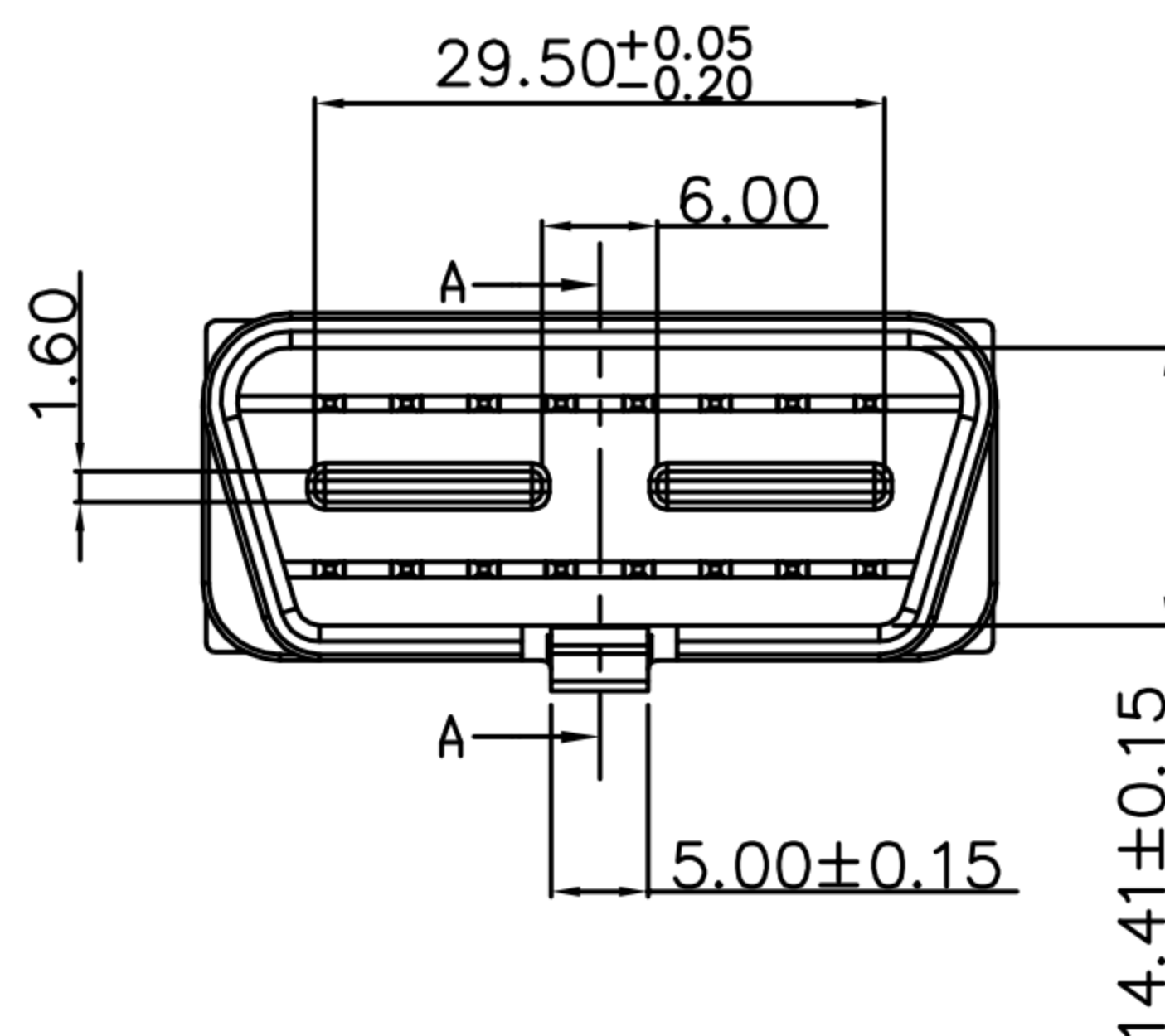

- MATERIAL :
 - 1-1. HOUSING : PC EXL9330 無鹵 (BK1A068)
 - 1-2. CONTACT : BRASS
- FINISH :
 - 2-1. CONTACT : BRIGHT TIN.
- Environmental :
 - 3-1. Operation Temperature : -40℃~85℃

DRAW	Ren Liao	APPVL	Fido Weng	UNIT	mm	TOLERANCE		广东科斯达电子科技有限公司 GUANG DONG KE SI DA ELECTRONIC TECHNOLOGY CO., LTD.	TITLE	OBD2 16P (M) 板±90° DIP (加長型)			SHEET	1
CHECK	Emily Suen			SCALE	1:1	.x ±0.20 .xx ±0.10 .xxx ±0.05 .xxxx ±0.03 ANGULA ±1°			PART NO.	OBD2-16M3-04-11	DWG NO.	QC7630	VERSION	A