

CUSTOMER DRAWING

REV.	DESCRIPTION	APPROVED BY	DATE	ECN NO.
A	PRELIMINARY RELEASE	Fido Weng	22/04/10*	
B	CHANGE CONTACT PLATED	Ku Chou	10/06/19	ECN-19006
C				

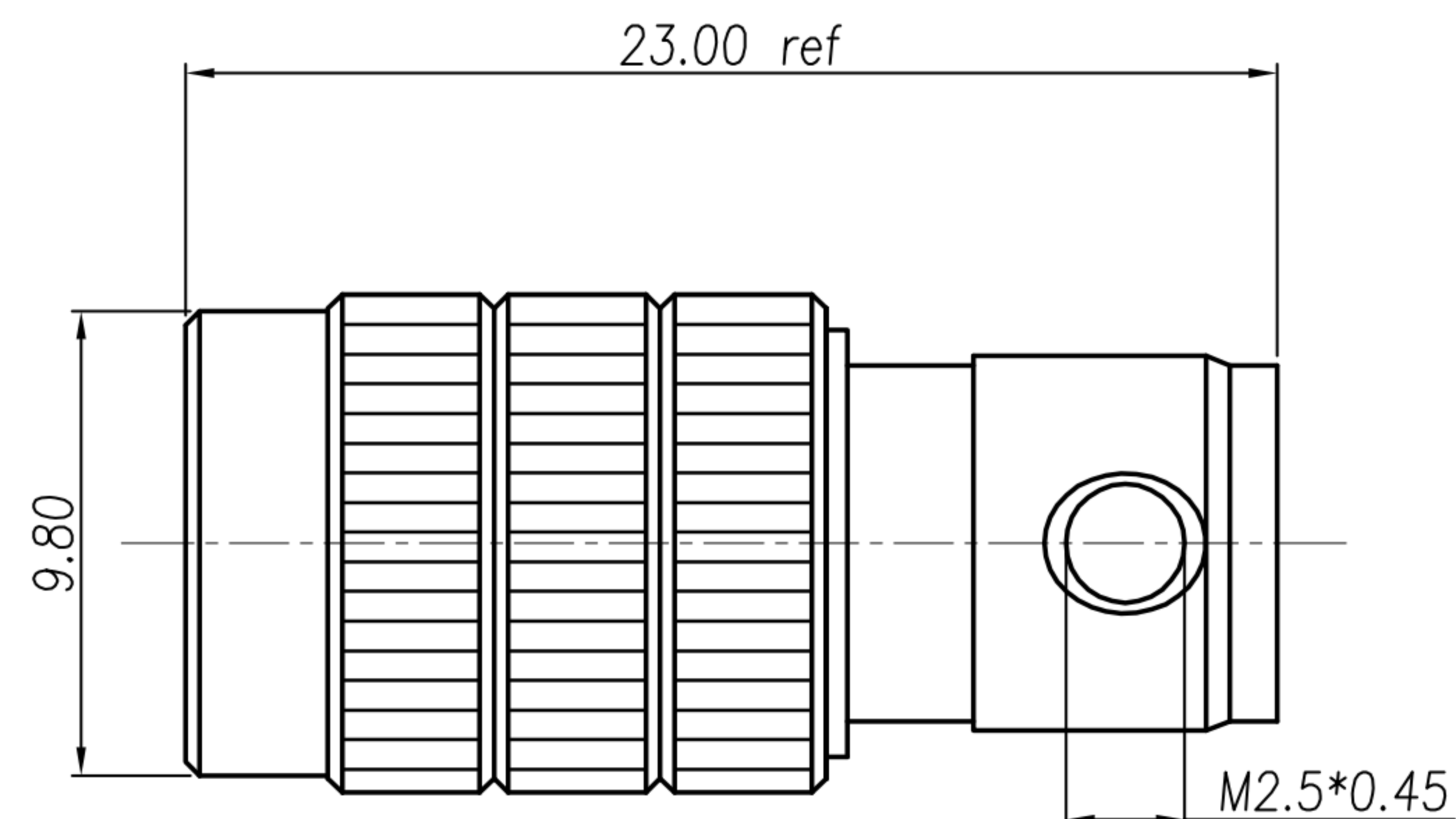
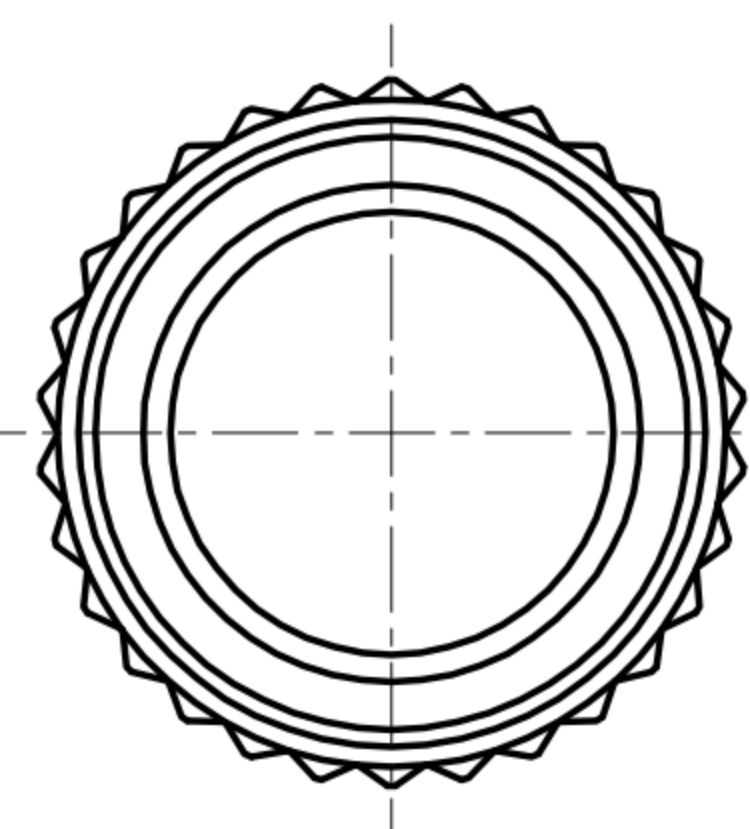
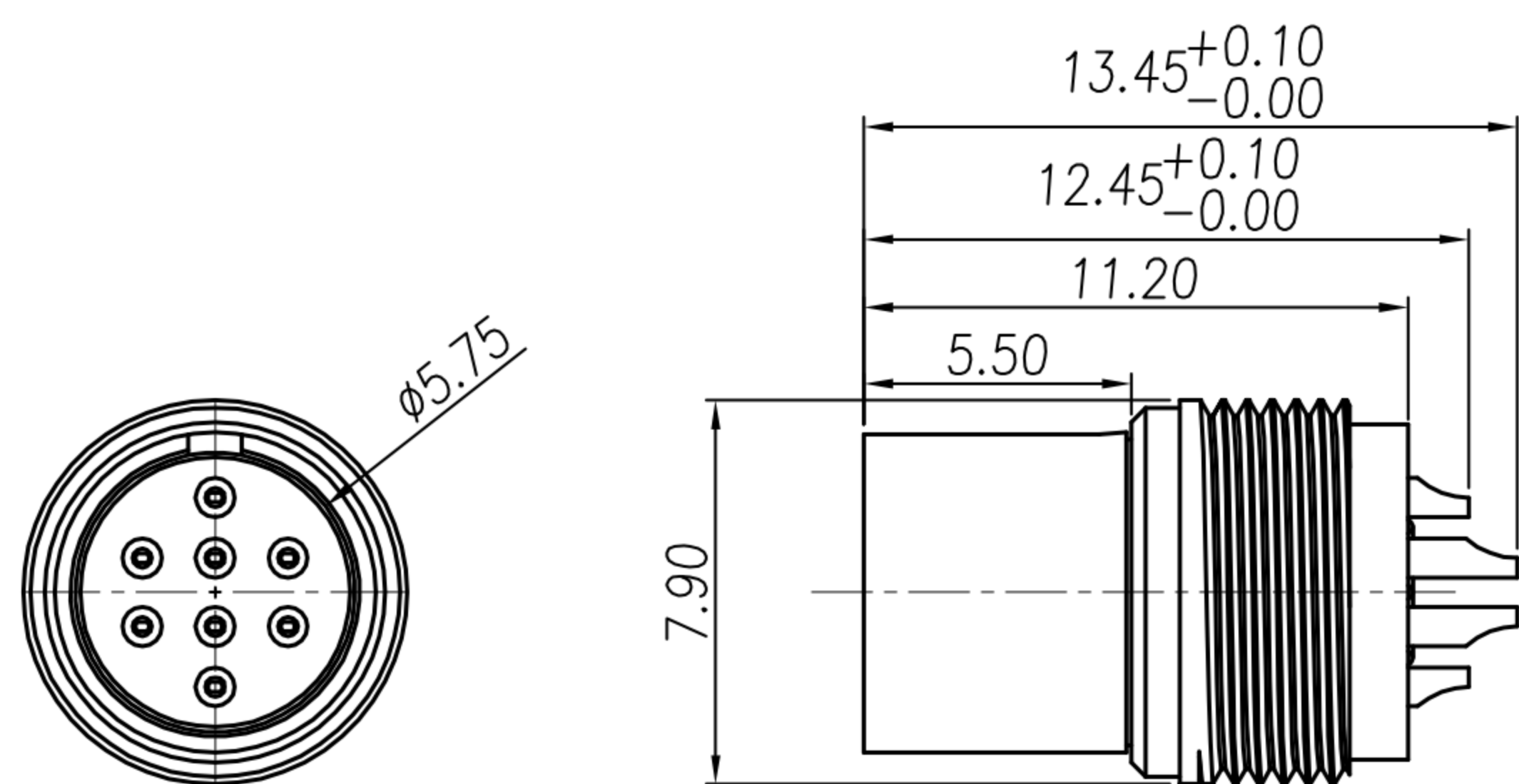

HOUSING+CONTACT+SHELL A+O-RING A

SHELL B+SHELL C+O-RING B

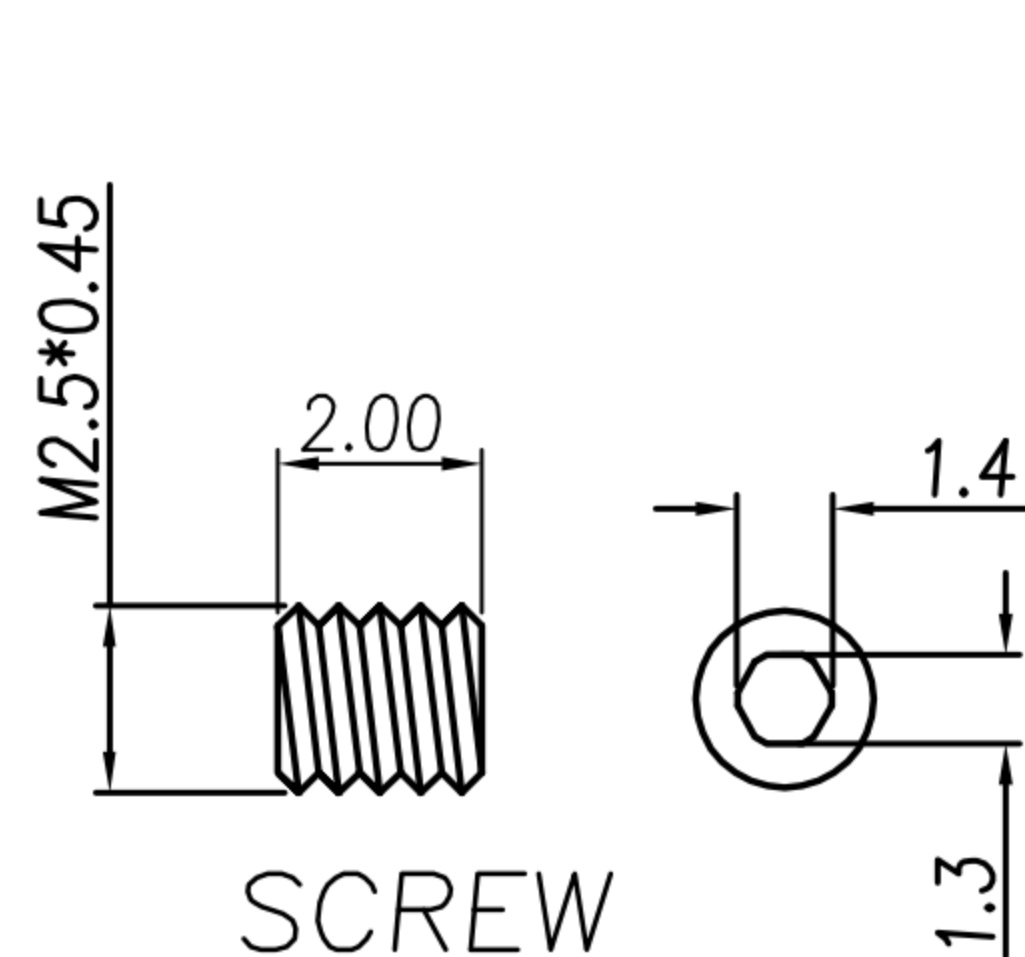

SCREW

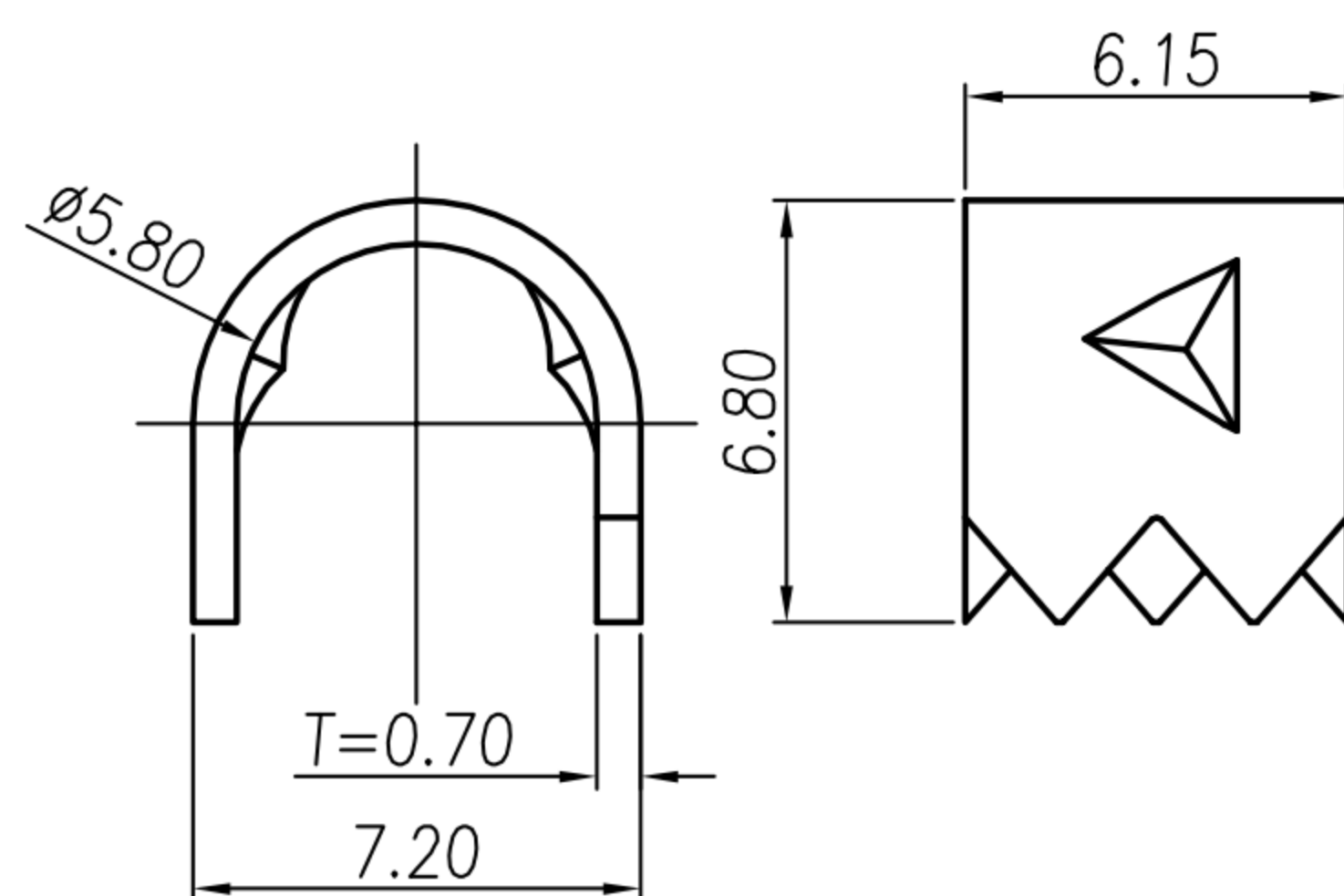

CLAMP

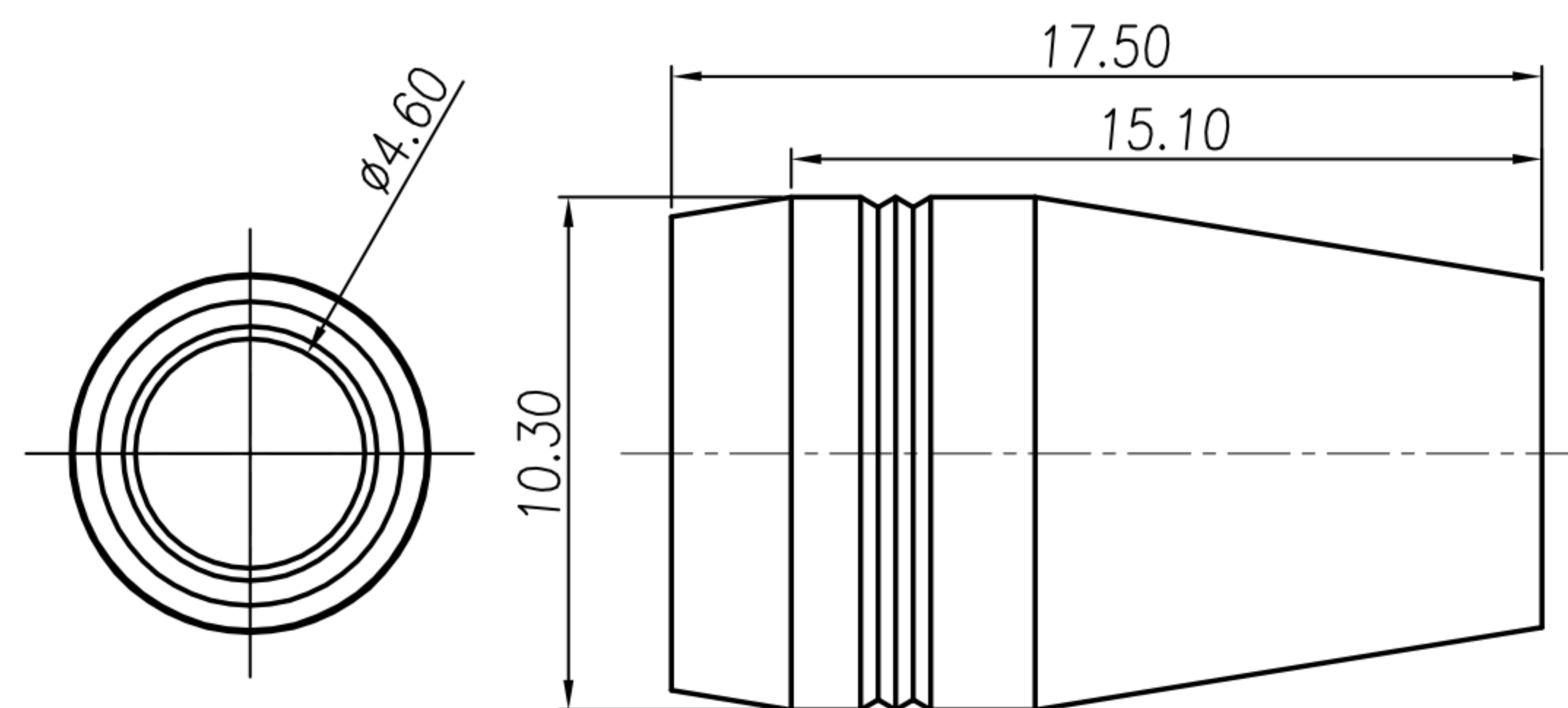

SR

DRAWN	Jen Xie	APP'D	Fido Weng	UNIT	mm	TOLERANCE		广东科斯达电子科技有限公司 GUANG DONG KE SI DA ELECTRONIC TECHNOLOGY CO., LTD.	TITLE	防水頭 M8*0.5 8PIN(F) 線端			SHEET	2/2
CHK'D	Emily Suen			SCALE	1:1	.x ±0.20 .xx ±0.10 .xxx ±0.05 .xxxx ±0.03 ANGULA ±1°			PART NO.	SEE TABLE A	DWG NO.	QC5181	VERSION	B



CUSTOMER DRAWING

REV.	DESCRIPTION	APPROVED BY	DATE	ECN NO.
△A	PRELIMINARY RELEASE	Fido Weng	22/04/10*	
△B	CHANGE CONTACT PLATED	Ku Chou	10/06/19	ECN-19006
△C	CHANGE MATERIAL	Ku Chou	16/09/22*	

1. MATERIAL :

- △ 1-1. HOUSING : NYLON 66 UL94V-0 ; COLOR : BLACK
- 1-2. CONTACT : PHOSPHOR BRONZE
- 1-3. SHELL A : ZINC ALLOY
- 1-4. SHELL B : BRASS
- 1-5. SHELL C : BRASS
- 1-6. O-RING A : EPDM; COLOR : BLACK
- 1-7. O-RING B : NBR; COLOR : BLACK
- 1-8. SPRING : STAINLESS
- 1-9. SCREW : ALLOY STEEL
- 1-10. SR : TPR

2. FINISH :

- 2-1. CONTACT A : 10u" MIN. GOLD PLATED △B
- 2-2. SHELL A : NICKEL PLATED 60u" ~ 100u" OVER ALL
- 2-3. SHELL B : NICKEL PLATED 60u" ~ 100u" OVER ALL
- 2-3. SHELL C : NICKEL PLATED 60u" ~ 100u" OVER ALL

3. ELECTRICAL SPECIFICATION :

- 3-1. Rated current : 1A
- 3-2. Rated Voltage : 30V AC , 42V DC

4. Environmental :

- 4-1. Operation Temperature : -25℃~85℃

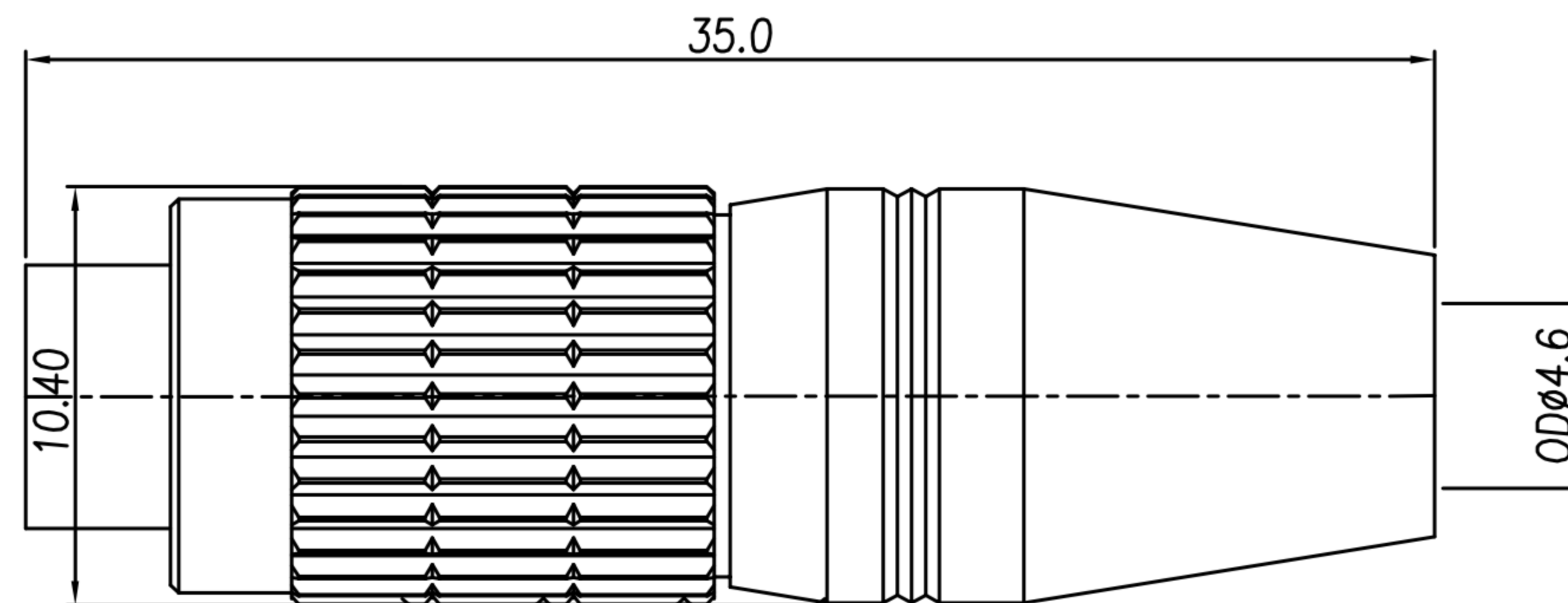
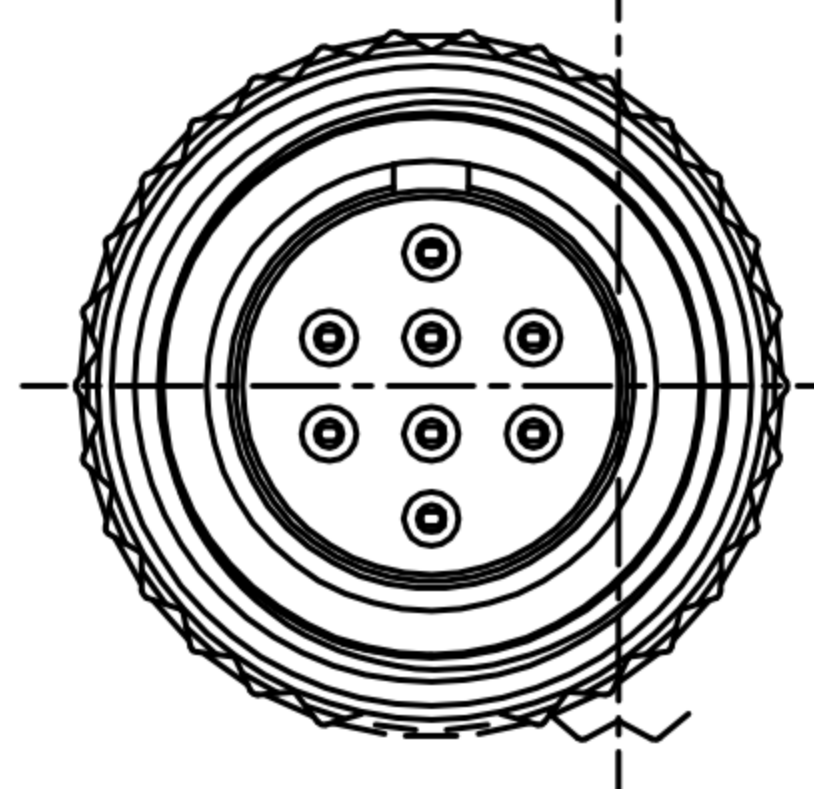

ASSEMBLY

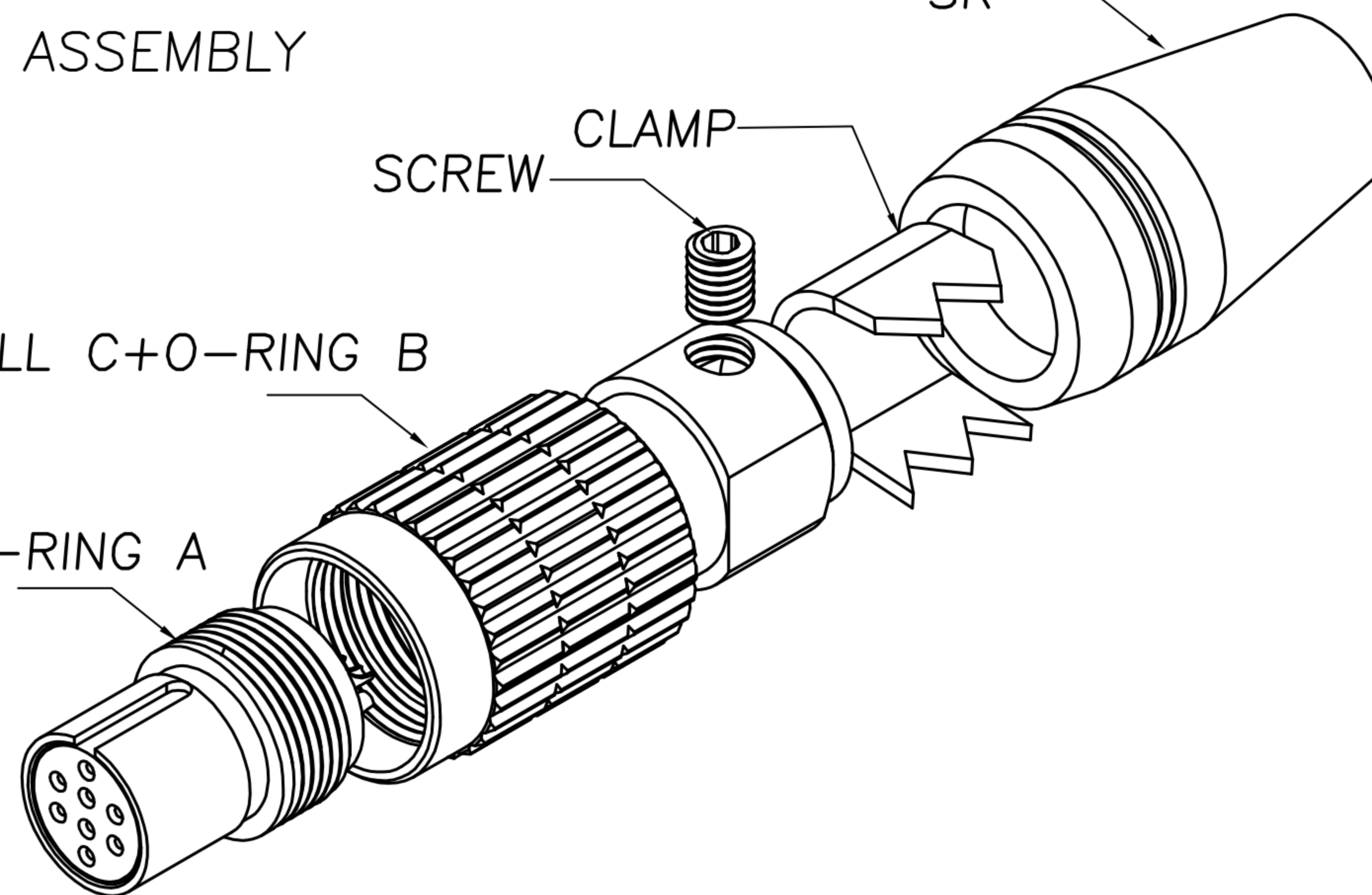

SHELL B+SHELL C+O-RING B

HOUSING+CONTACT+SHELL A+O-RING A

TABLE A

DI-04F2-01(4P)	DI-06F2-02(6P)	DI-08F2-01(8P) DI-08F2-19-11(無耐落)

DRAWN	Jen Xie	APP'D	Fido Weng	UNIT	mm	TOLERANCE			TITLE	防水頭 M8*0.5 8PIN(F) 線端			SHEET	1/2
CHK'D	Emily Suen			SCALE	1:1	.x ±0.20 .xx ±0.10 .xxx ±0.05 .xxxx ±0.03 ANGULA ±1°			PART NO.	SEE TABLE A	DWG NO.	QC5181	VERSION	C