

CUSTOMER DRAWING

REV.	DESCRIPTION	APPVL. BY	DATE	ECN NO.
△A	RELEASE	Fido Weng	18/04/19'	
△B	ADD TABLE A	Fido Weng	03/06/19'	
△C				

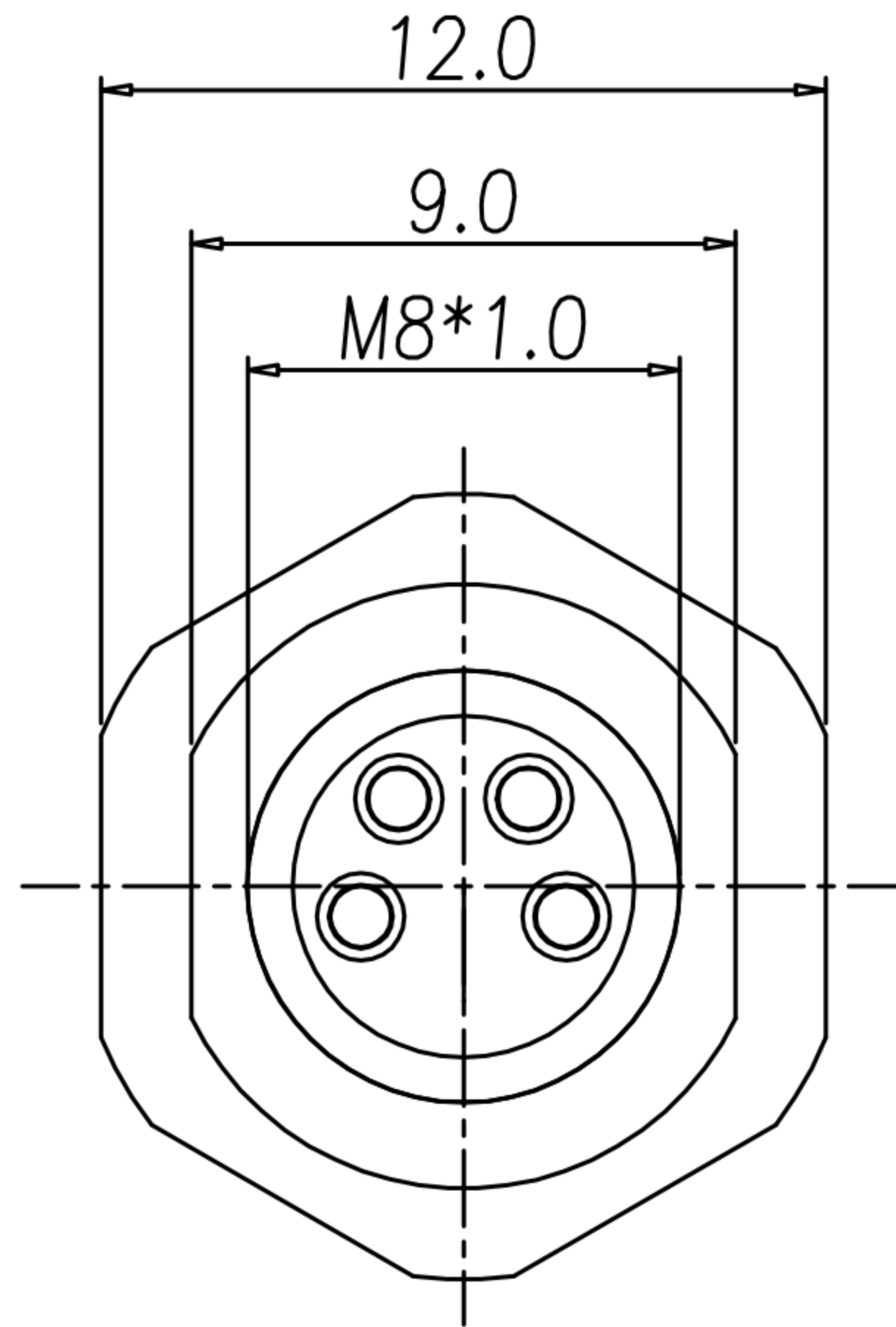
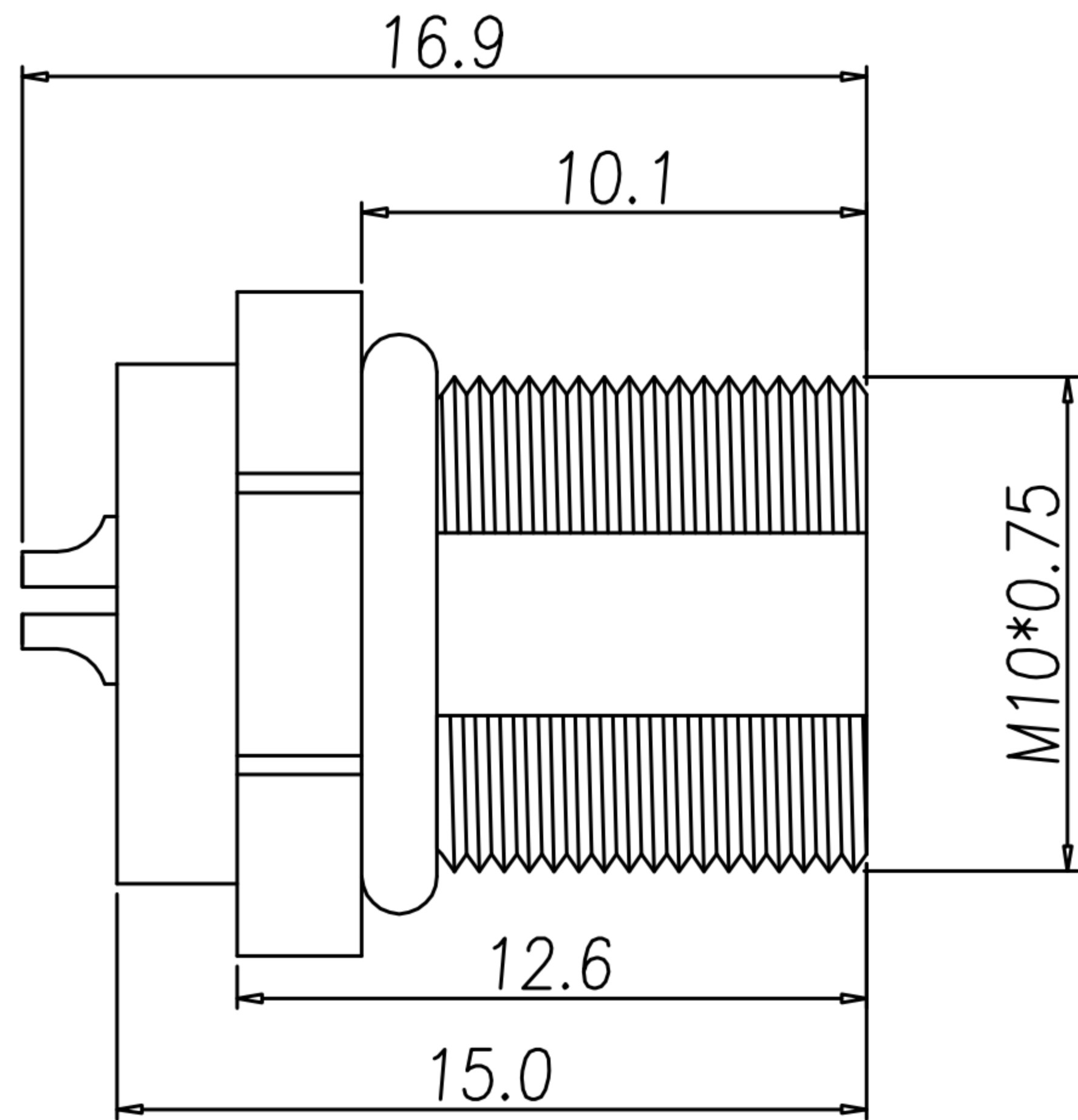

△B TABLE A

WP-04F2-226-11	WP-02F2-84-11
WP-03F2-143-11	

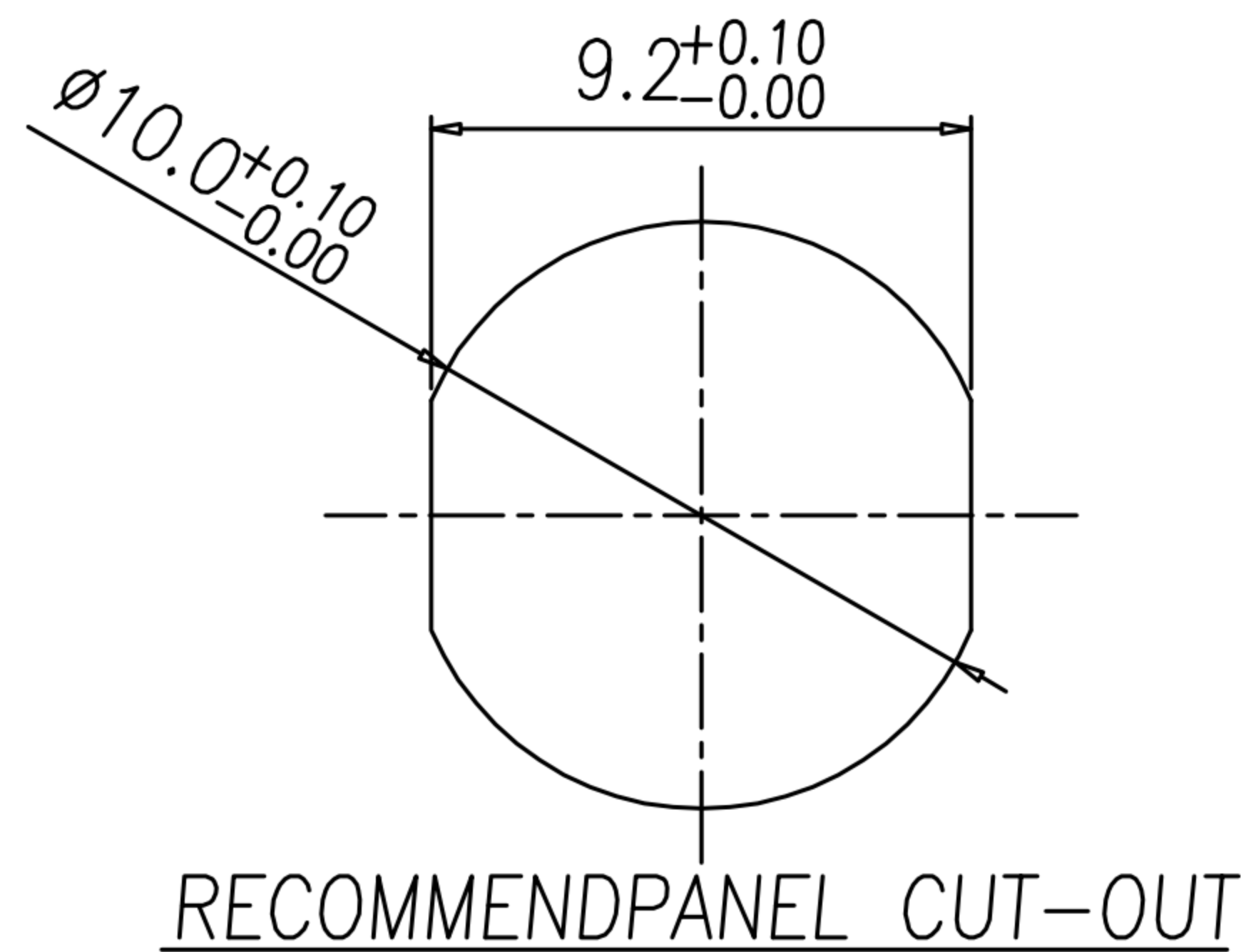
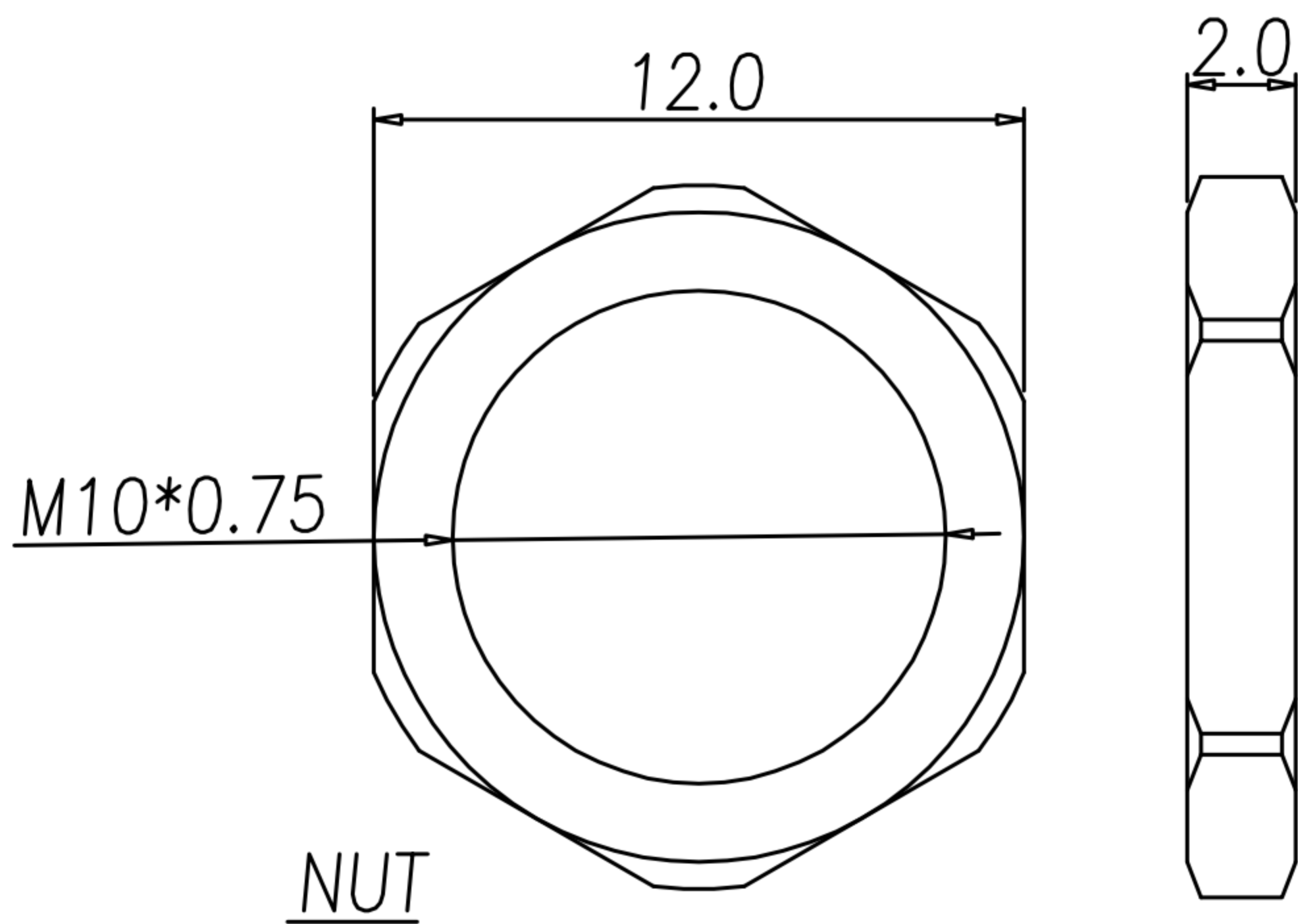

NOTE:

- MATERIAL :
 - 1-1. HOUSING : PA66 ; COLOR : BLACK
 - 1-2. CONTACT : BRASS.
 - 1-3. SHELL : BRASS.
 - 1-4. NUT : BRASS.
 - 1-5. O-RING : EPDM ; COLOR : BLACK
- FINISH :
 - 2-1. CONTACT : GOLD FLASH PLATED
 - 2-2. SHELL : NICKEL PLATED.
 - 2-3. NUT : NICKEL PLATED.
- ELECTRICAL SPECIFICATION :
 - 3-1. Rated current : 4A
 - 3-2. Rated Voltage : 60V
 - 3-3. Water proof : IP67
- Environmental :
 - 4-1. Operation Temperature : -40℃~105℃

DRAW	Ku Chou	APPVL	Emily Suen	UNIT	mm	TOLERANCE		广东科斯达电子科技有限公司 GUANG DONG KE SI DA ELECTRONIC TECHNOLOGY CO., LTD.	TITLE	M8 (F) 前鎖M10*0.75線式			SHEET	1 VERSION B
CHECK	Ku Chou			SCALE	1:1	.x ±0.20 .xx ±0.10 .xxx ±0.05 .xxxx ±0.03 ANGULA ±1°			PART NO.	SEE TABLE A	DWG NO.	QC9119		