

CUSTOMER DRAWING

REV.	DESCRIPTION	APPROVED BY	DATE	ECN NO.
A	RELEASE	Emily Suen	30/12/11'	
B				
C				

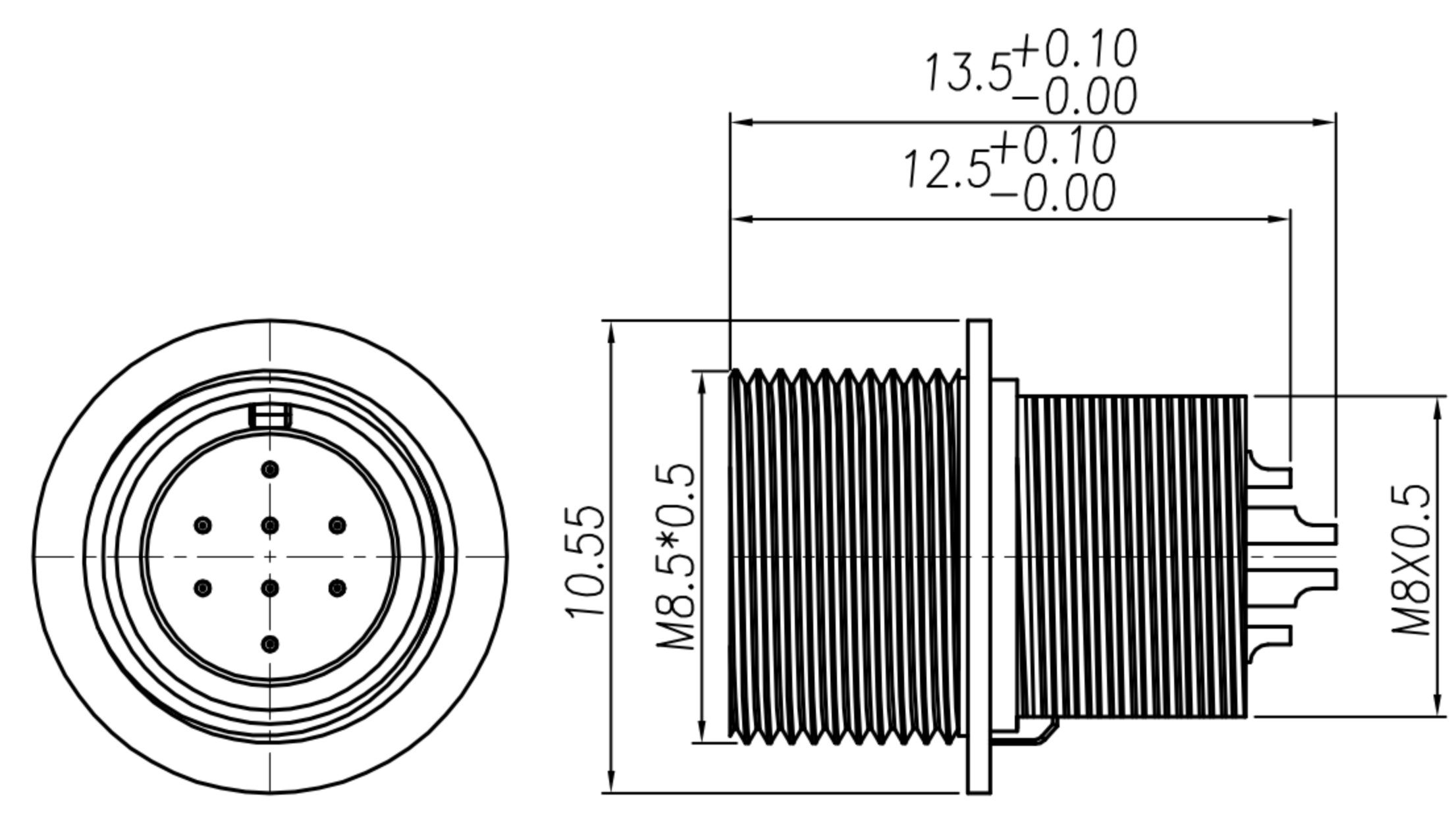

HOUSING+CONTACT+SHELL A

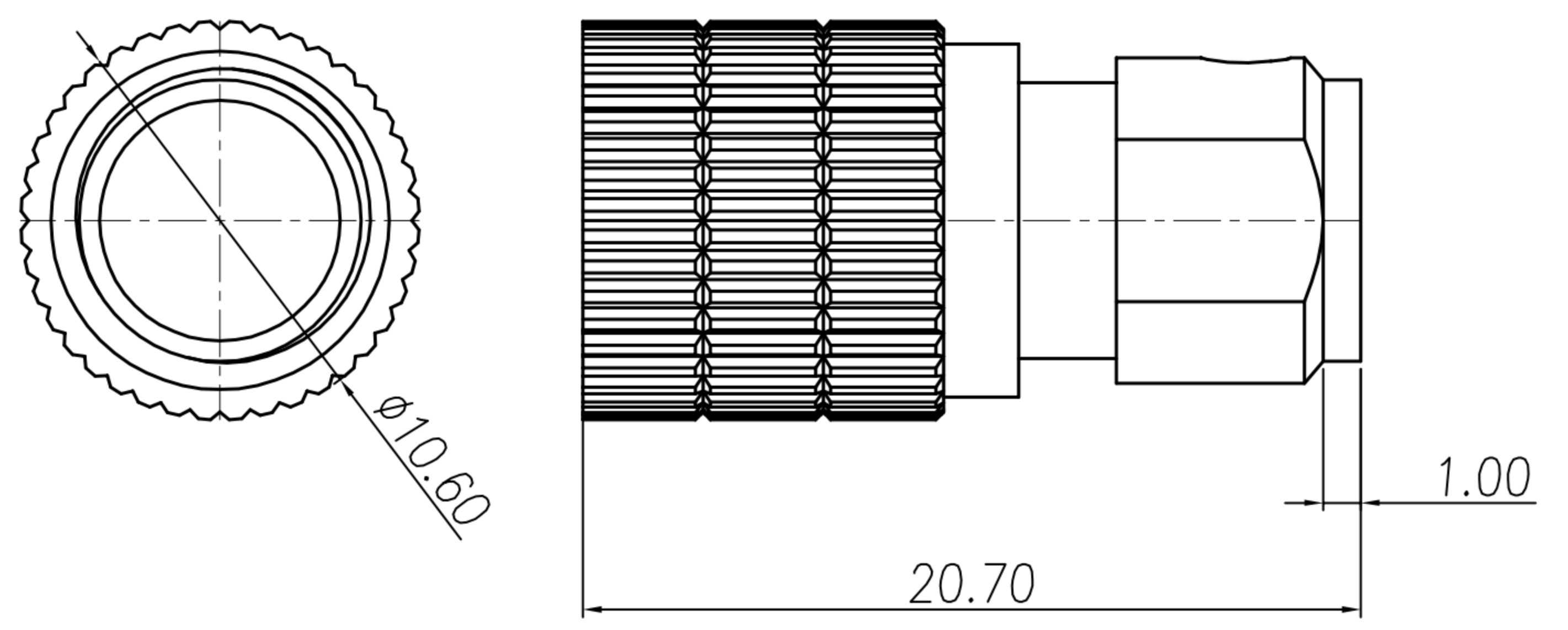

SHELL B+O-RING A

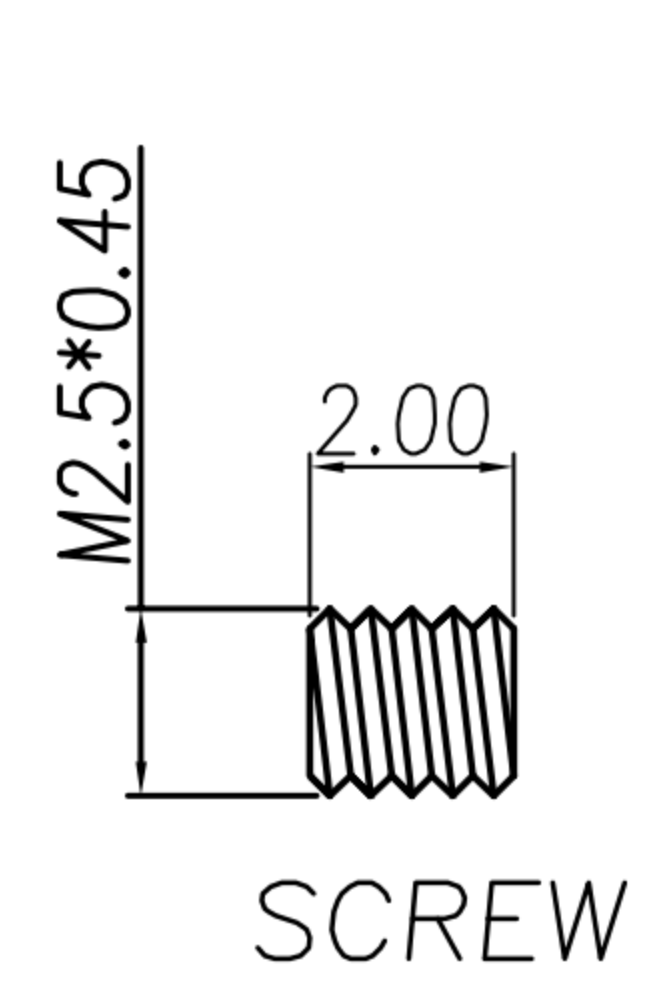

SCREW

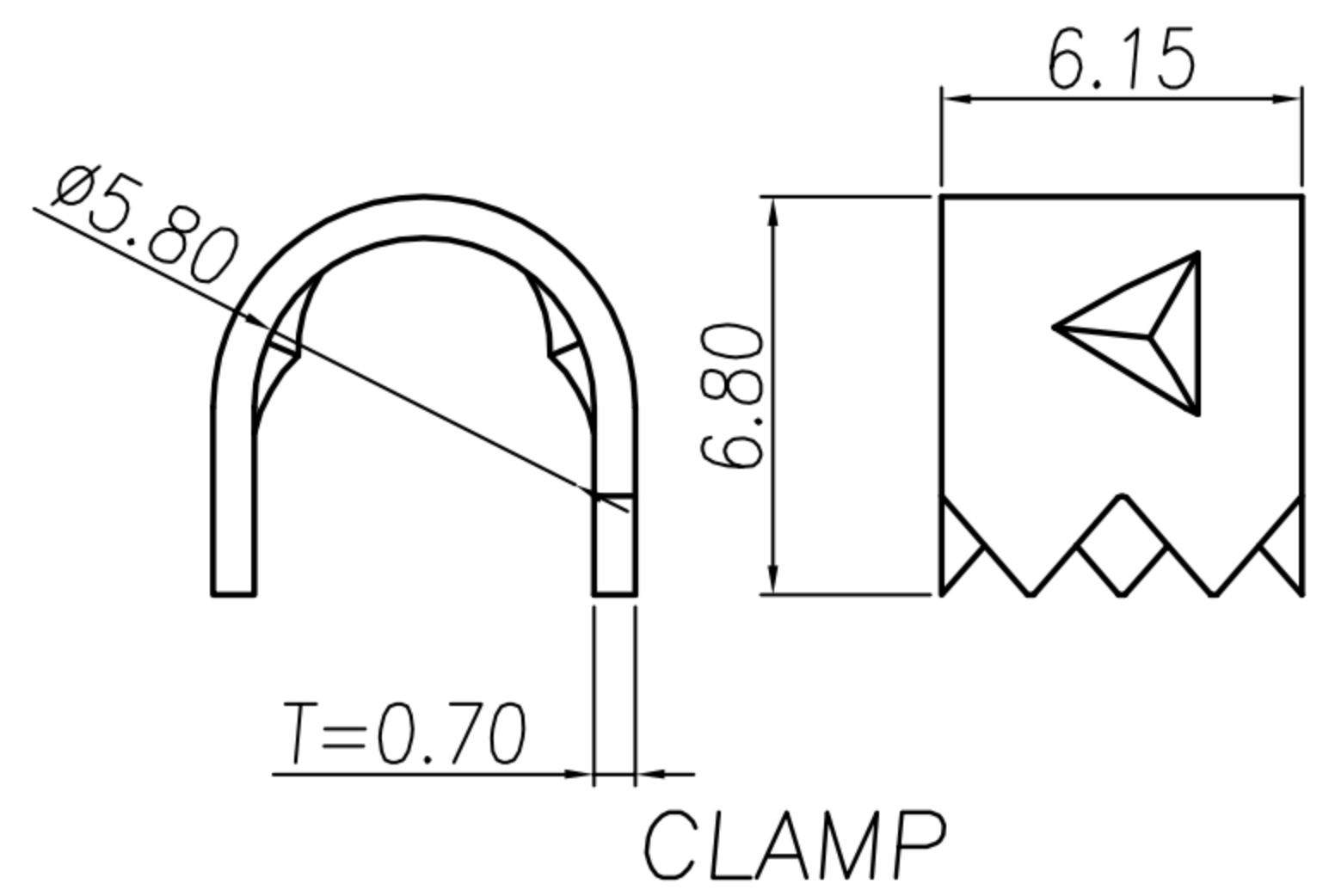
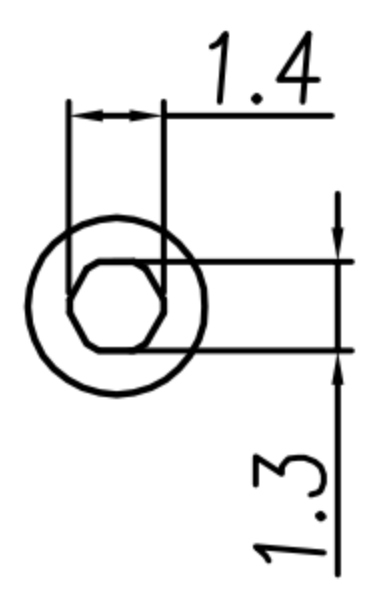

CLAMP

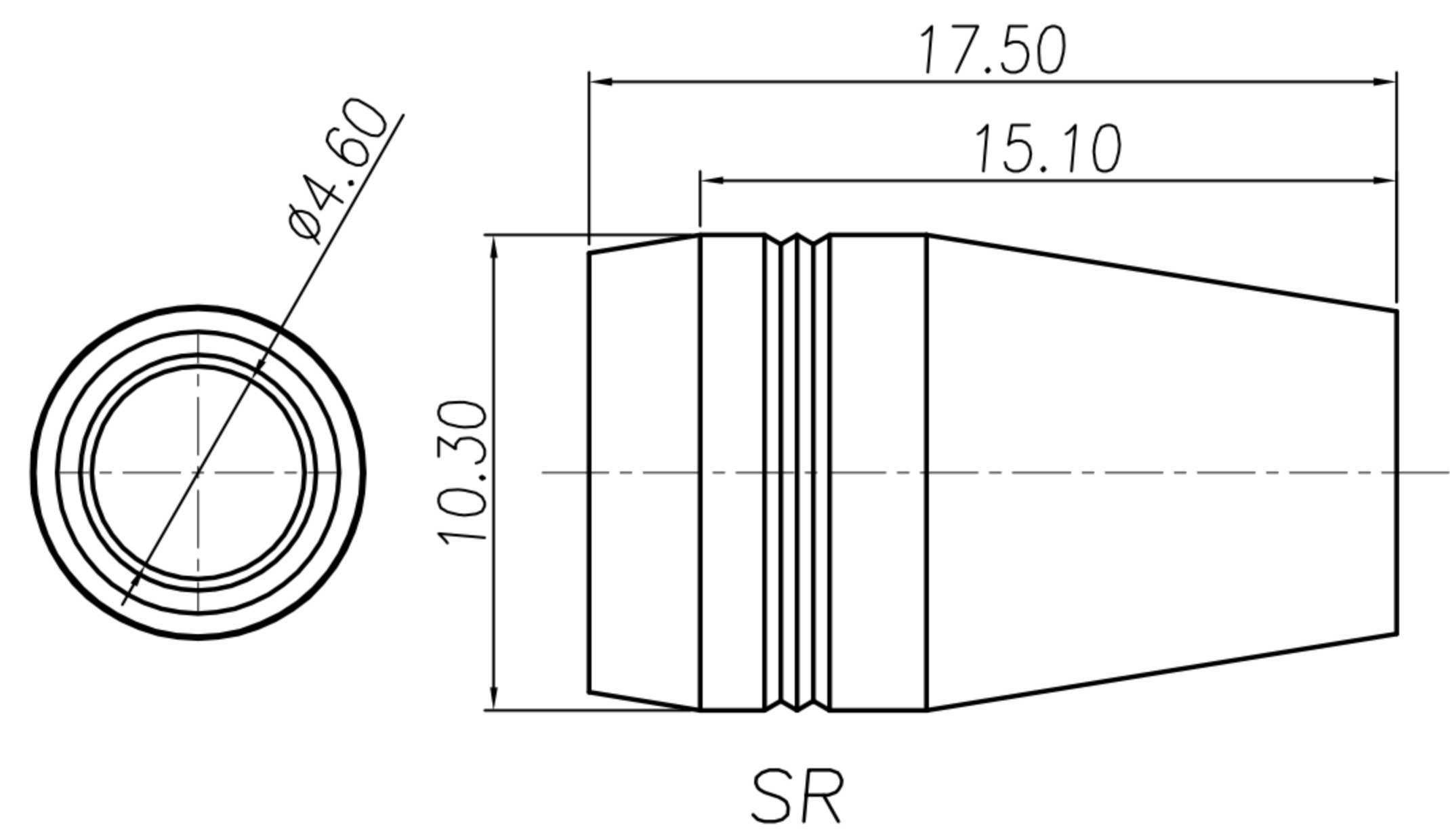

SR

DRAWN	Mark Kao	APP'D	Ku Chou	UNIT	mm	TOLERANCE .x ±0.20 .xx ±0.10 .xxx ±0.05 .xxxx ±0.03 ANGULA ±1°		广东科斯达电子科技有限公司 GUANG DONG KE SI DA ELECTRONIC TECHNOLOGY CO., LTD.	TITLE	DIN M8*0.5 (M) 線纜式(SHELL:JACK)			SHEET	2/2
CHK'D	Emily Suen			SCALE	1:1				PART NO.	SEE TABLE A	DWG NO.	QC5632	VERSION	A



CUSTOMER DRAWING

REV.	DESCRIPTION	APPROVED BY	DATE	ECN NO.
△A	RELEASE	Emily Suen	30/12/11'	
△B	CHANGE MATERIAL	Emily Suen	15/09/22'	
△C				

1. MATERIAL :

- △B 1-1. HOUSING : NYLON 66 UL94V-0 ; COLOR : BLACK
- 1-2. CONTACT : BRASS
- 1-3. SHELL A : Zinc Alloy
- 1-4. SHELL B : BRASS
- 1-5. O-RING A : NBR; COLOR : BLACK
- 1-6 SCREW : ALLOY STEEL
- 1-7. CLAMP : BRASS
- 1-8. SR : TPR

2. FINISH :

- 2-1. CONTACT A : 10 MICRO INCHES MIN. GOLD PLATED
- 2-2. SHELL A : NICKEL PLATED 60u" ~ 100u" OVER ALL
- 2-3. SHELL B : NICKEL PLATED 60u" ~ 100u" OVER ALL
- 2-4 SCREW : NICKEL PLATED 60u" ~ 100u" OVER ALL

3. ELECTRICAL SPECIFICATION :

- 3-1. Rated current : 1A
- 3-2. Rated voltage : 30V AC , 42V DC

4. Environmental :

- 4-1. Operation Temperature : -25℃~85℃

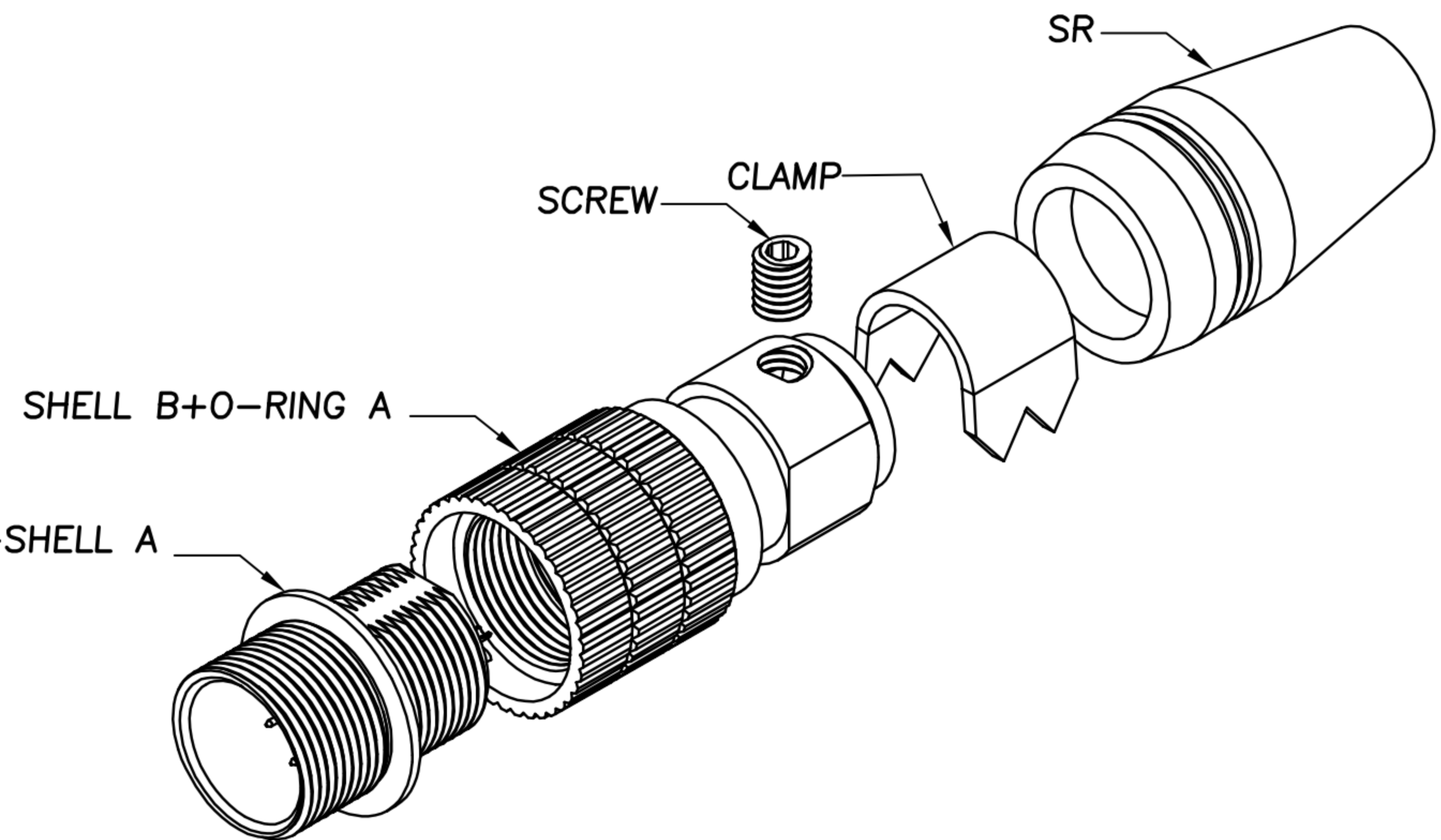
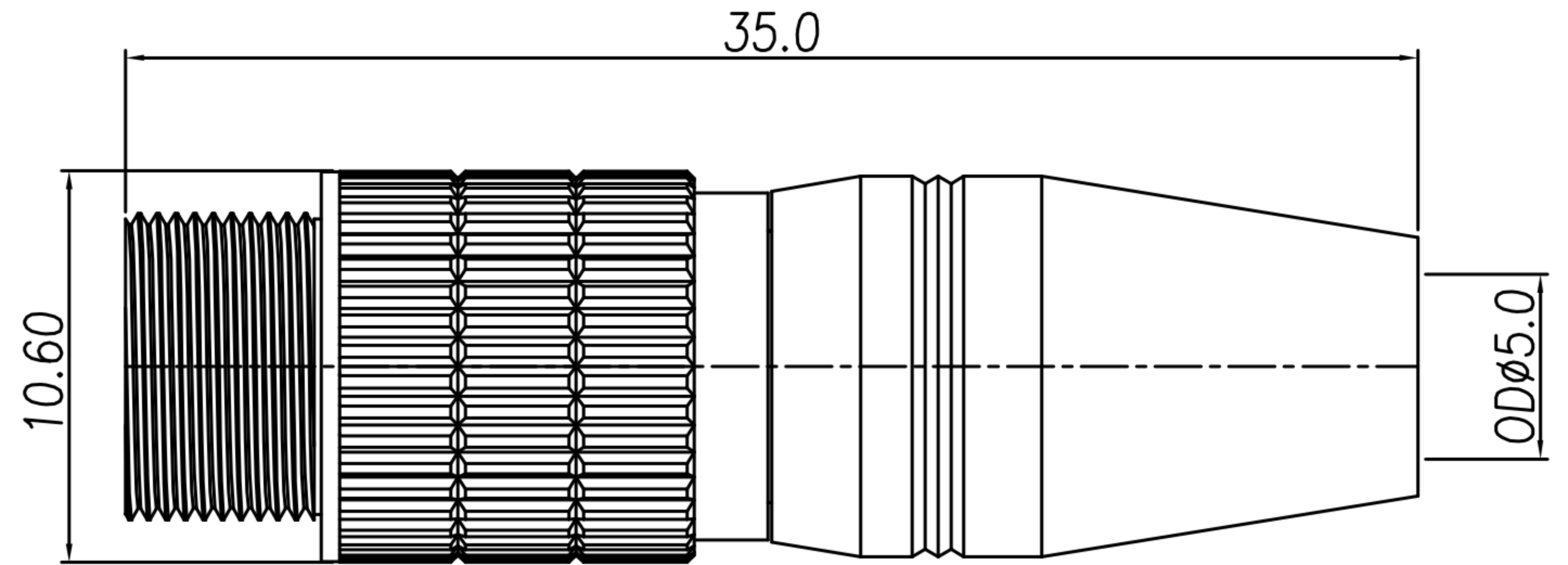
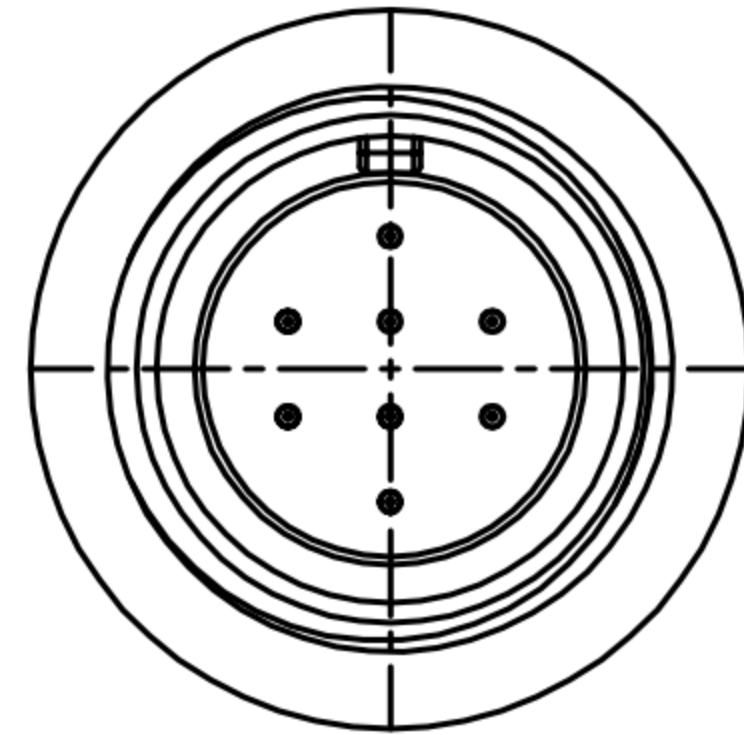

TABLE A

DI-04M2-04(4P)	DI-06M2-03(6P)	DI-08M2-07(8P)

DRAWN	Mark Kao	APP'D	Ku Chou	UNIT	mm	TOLERANCE			广东科斯达电子科技有限公司 GUANG DONG KE SI DA ELECTRONIC TECHNOLOGY CO., LTD.	TITLE	DIN M8*0.5 (M) 線端式(SHELL:JACK)			SHEET	1/2
CHK'D	Emily Suen			SCALE	1:1					PART NO.	SEE TABLE A	DWG NO.	QC5632	VERSION	B