

CUSTOMER DRAWING

REV.	DESCRIPTION	APPROVED BY	DATE	ECN NO.
A	RELEASE	Ku Chou	18/03/19*	
B				
C				

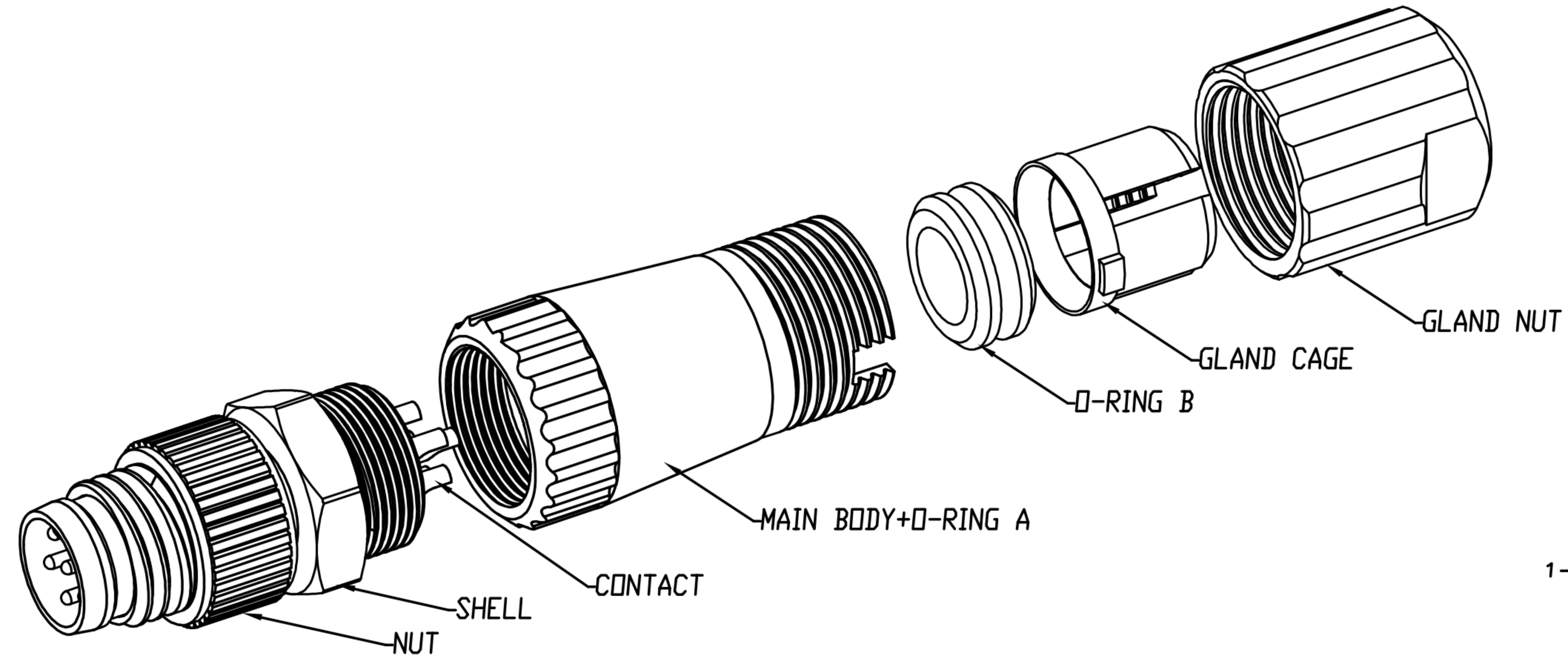

TABLE A

WP-06M2-75-11	WP-05M2-167-11

- 1-1. MATERIAL A
  - a. HOUSING : PA66 UL94V-0 ; COLOR : BLACK.
  - b. CONTACT : BRASS
  - c. NUT : BRASS
  - d. SHELL : BRASS
- 1-2. MATERIAL B
  - a. MAIN BODY : PA66 ; COLOR : BLACK
  - b. O-RING A : SILICONE ; COLOR : BLACK
- 1-3. O-RING B : NBR COLOR : BLACK.
- 1-4. GLAND CAGE : PA66 ; COLOR : WHITE.
- 1-5. GLAND NUT : PA66 ; COLOR : BLACK

2. FINISH :

- 2-1. MATERIAL A
  - a. CONTACT : GOLD FLASH PLATED.
  - UNDER PLATE : NICKEL.
  - b. NUT : NICKEL PLATED.
  - c. SHELL : NICKEL PLATED.

3. ELECTRICAL SPECIFICATION :

- 3-1. Rated current : 2A
- 3-2. Rated voltage : 30V
- 3-3. Water proof : IPX7

4. Environmental :

- 4-1. Operation Temperature : -20℃~85℃

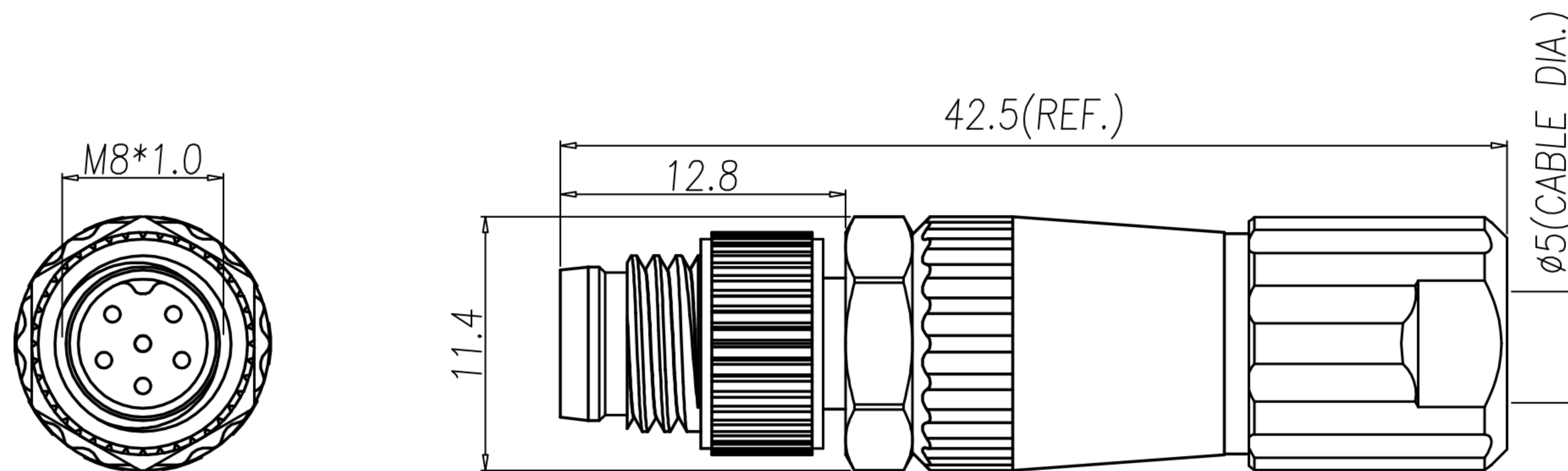

DRAWN	Emily Suen	APP'D	Ku Chou	UNIT	mm	TOLERANCE		广东科斯达电子科技有限公司 GUANG DONG KE SI DA ELECTRONIC TECHNOLOGY CO., LTD.	TITLE	M8 (M) Assembly type(92°)			SHEET
CHK'D	Ku Chou			SCALE	1:1	.x ±0.20 .xx ±0.10 .xxx ±0.05 .xxxx ±0.03 ANGULA ±1°			PART NO.	SEE TABLE A	DWG NO.	QC9747	VERSION