

CUSTOMER DRAWING

REV.	DESCRIPTION	APPVL. BY	DATE	ECN NO.
A	RELEASE	Fido	16/05/17'	
B				
C				

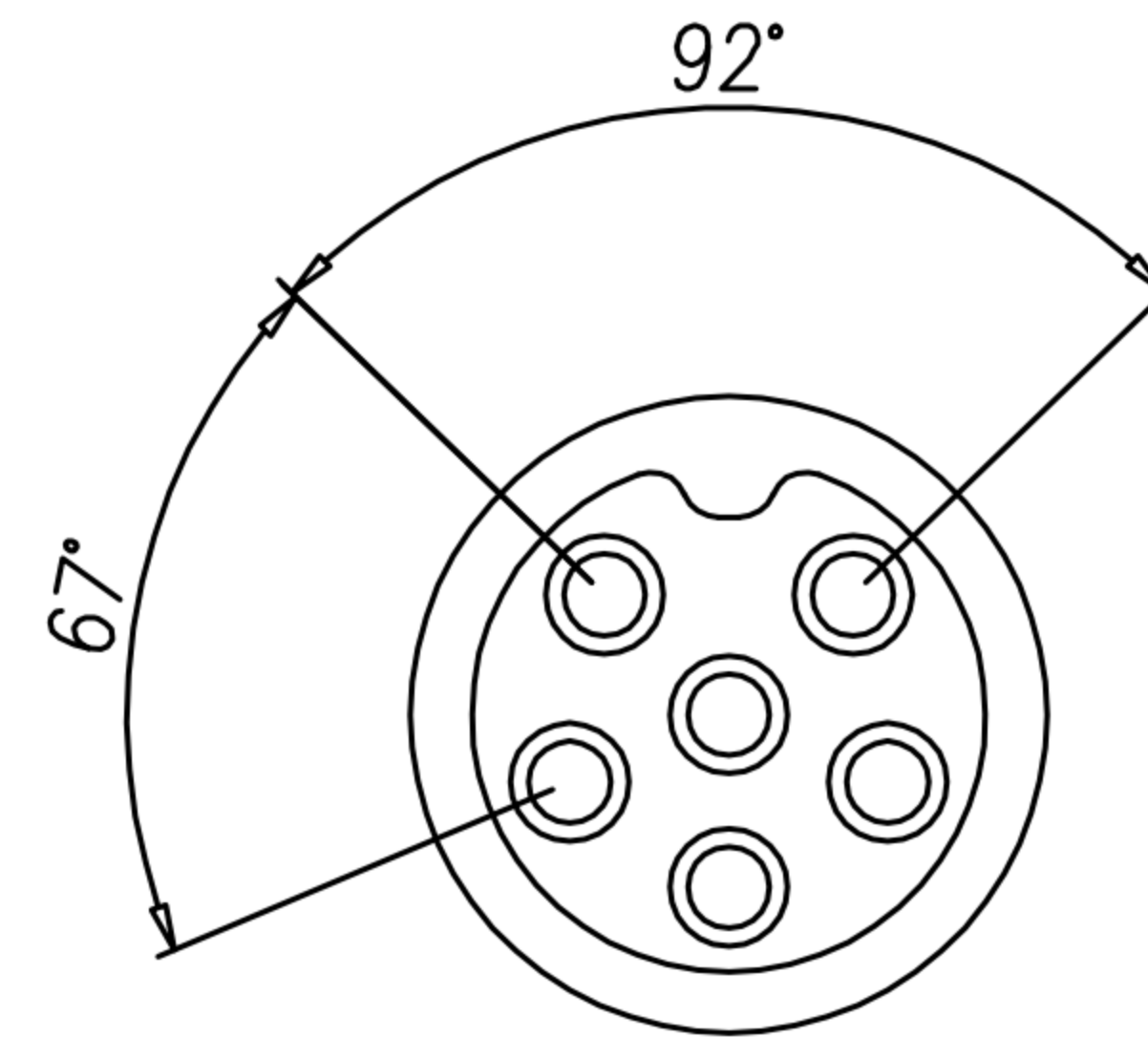
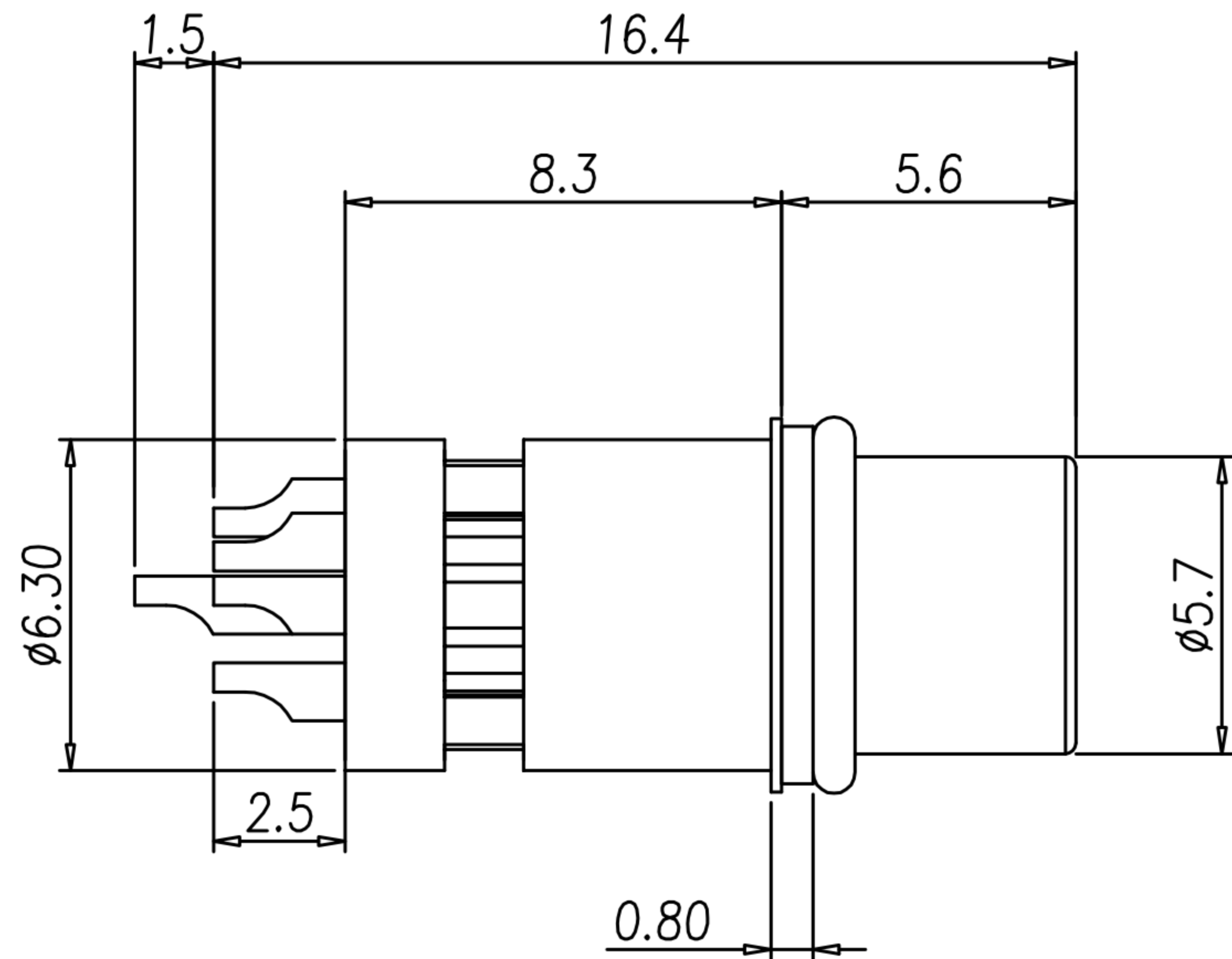

NOTE

- MATERIAL :
 - HOUSING : PA66 UL94V-0 ; COLOR : BLACK
 - CONTACT : BRASS
 - NUT : SEE TABLE A
 - O-RING : NBR
 - SHELL : SEE TABLE A
- FINISH :
 - CONTACT : GOLD 10 MICRO INCHES MIN.
 - SHELL : SEE TABLE A
 - NUT : SEE TABLE A
- ELECTRICAL SPECIFICATION :
 - Rated current : 2A
 - Rated Voltage : 30V
 - Water proof : IP67
- Environmental :
 - Operation Temperature : -40°C~105°C

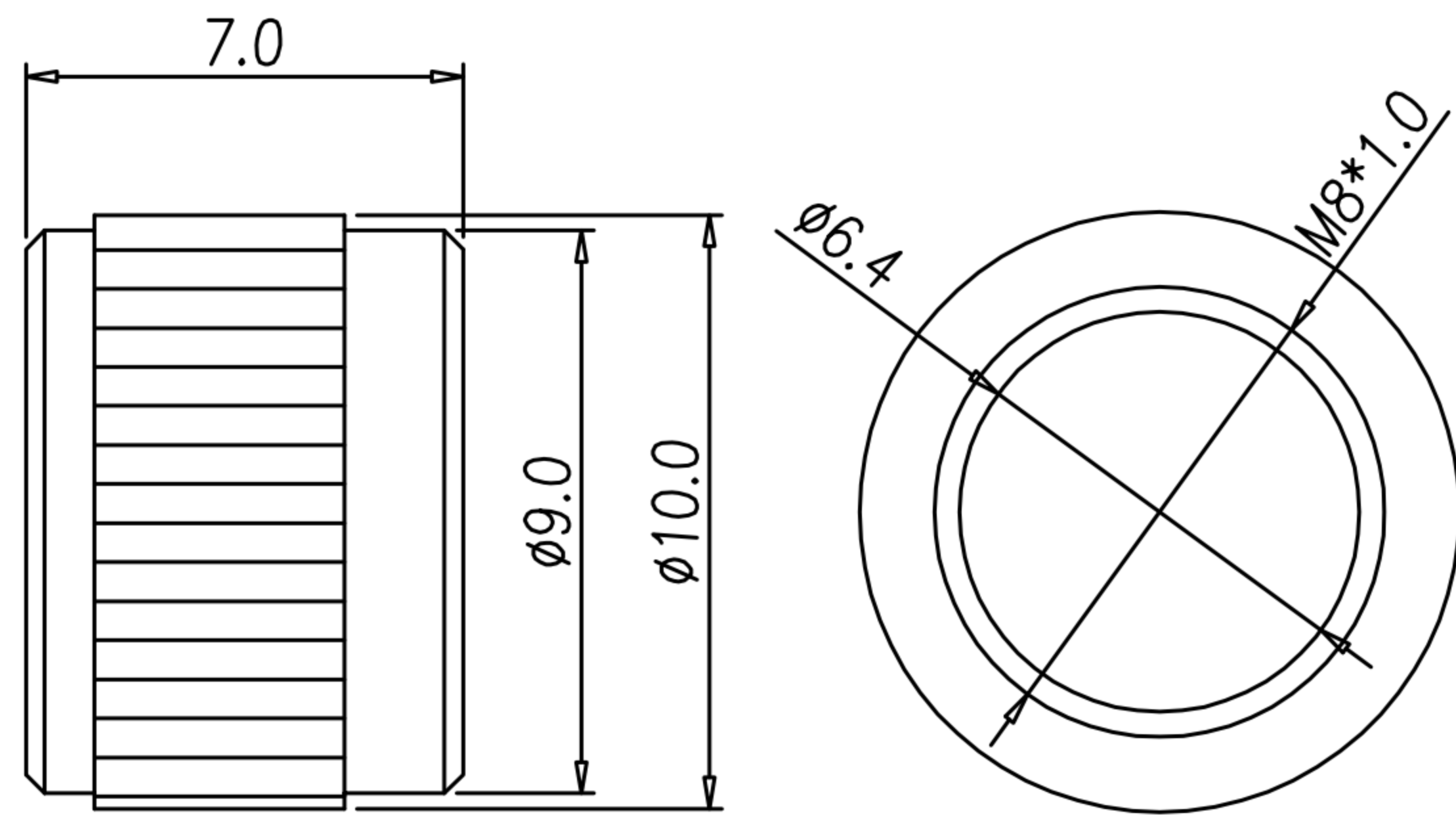

NUT

TABLE A

5PIN		6PIN		
WP-05F2-193-11		WP-06F2-52-11 WP-06F2-53-11 WP-06F2-54-11		
WP-05F2-193-11	BRASS	NICKEL PLATED.	BRASS	NICKEL PLATED.
WP-06F2-52-11	Stainless steel 316	-	Stainless steel 316	-
WP-06F2-53-11	BRASS	NICKEL PLATED.	BRASS	NICKEL PLATED.
WP-06F2-54-11	Stainless steel 316	-	BRASS	NICKEL PLATED.
P/N	MATERIAL(NUT)	PLATED(NUT)	MATERIAL(SHELL)	PLATED(SHELL)

DRAW	Ku Chou	APPVL	Emily Suen	UNIT	mm	TOLERANCE		广东科斯达电子科技有限公司 GUANG DONG KE SI DA ELECTRONIC TECHNOLOGY CO., LTD.	TITLE	M8 (F) 線端接地線式(梅花型92°)			SHEET	1
CHECK	Ku Chou			SCALE	1:1	.x ±0.20 .xx ±0.10 .xxx ±0.05 .xxxx ±0.03 ANGULA ±1°			PART NO.	SEE TABLE A	DWG NO.	QC7901	VERSION	A