

CUSTOMER DRAWING

REV.	DESCRIPTION	APPROVED BY	DATE	ECN NO.
A	ADD NEW PART NO.	Fido Weng	10/12/07	
B	CHANGE VIEW	Fido Weng	27/05/08	
C	ADD NEW PART NO.	Fido Weng	03/03/09	ECN09022

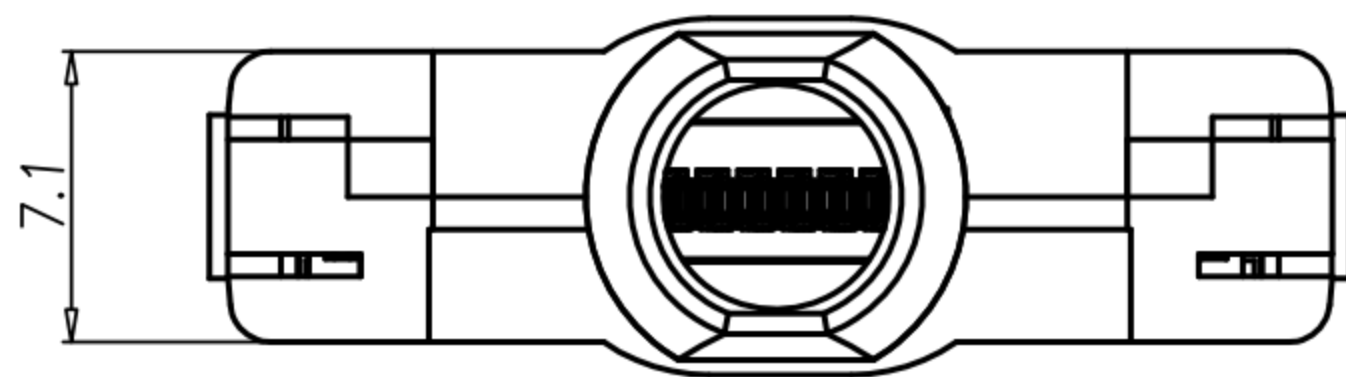
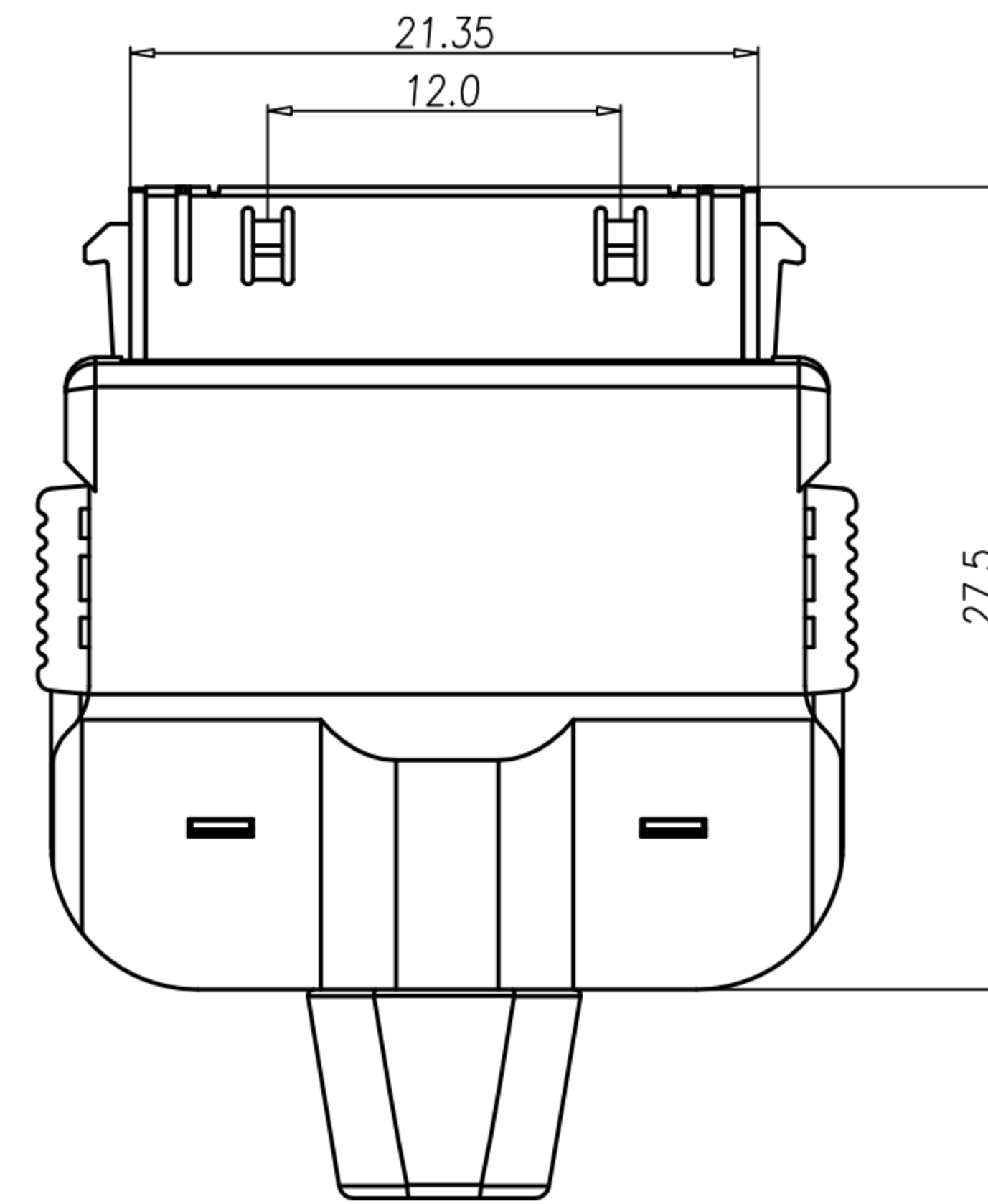
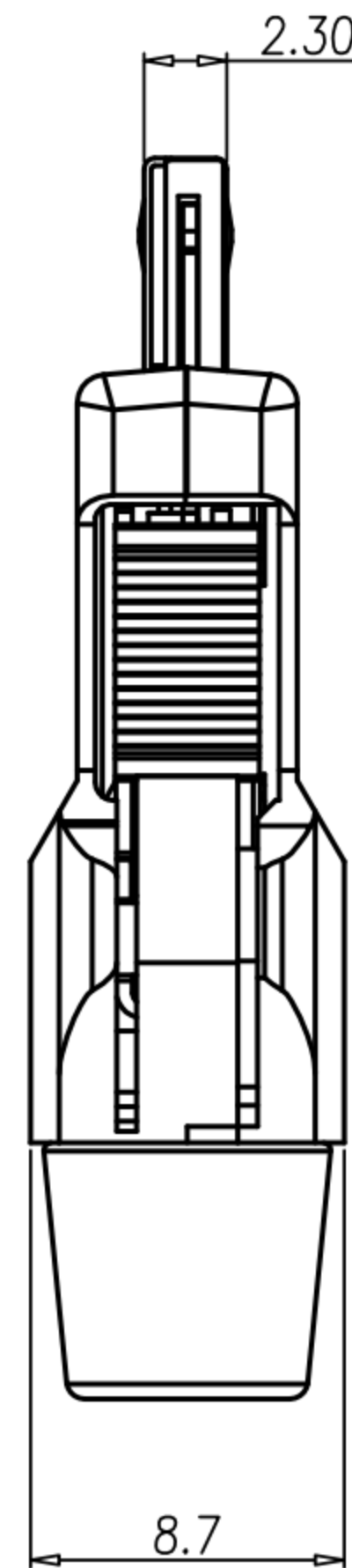
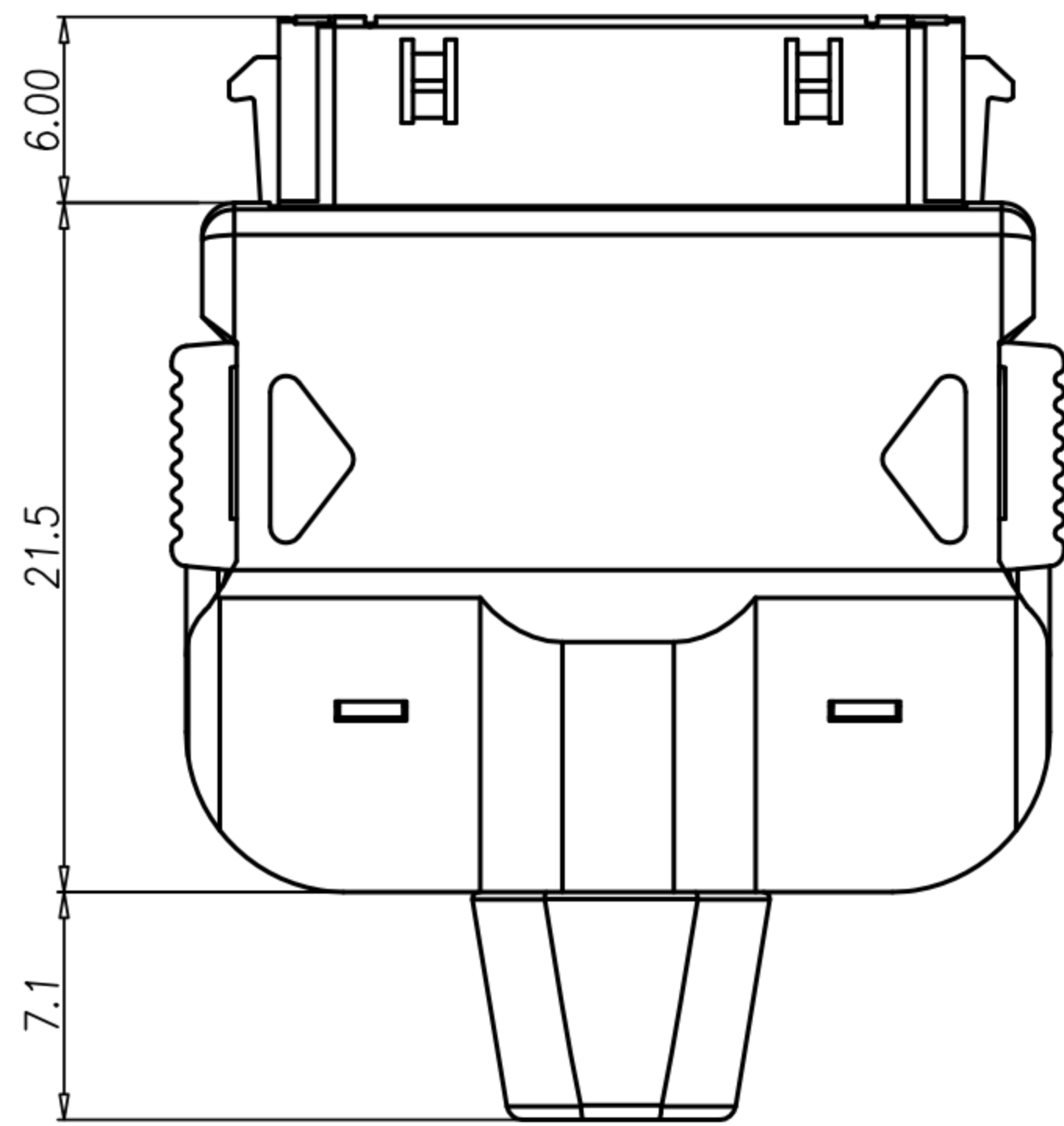
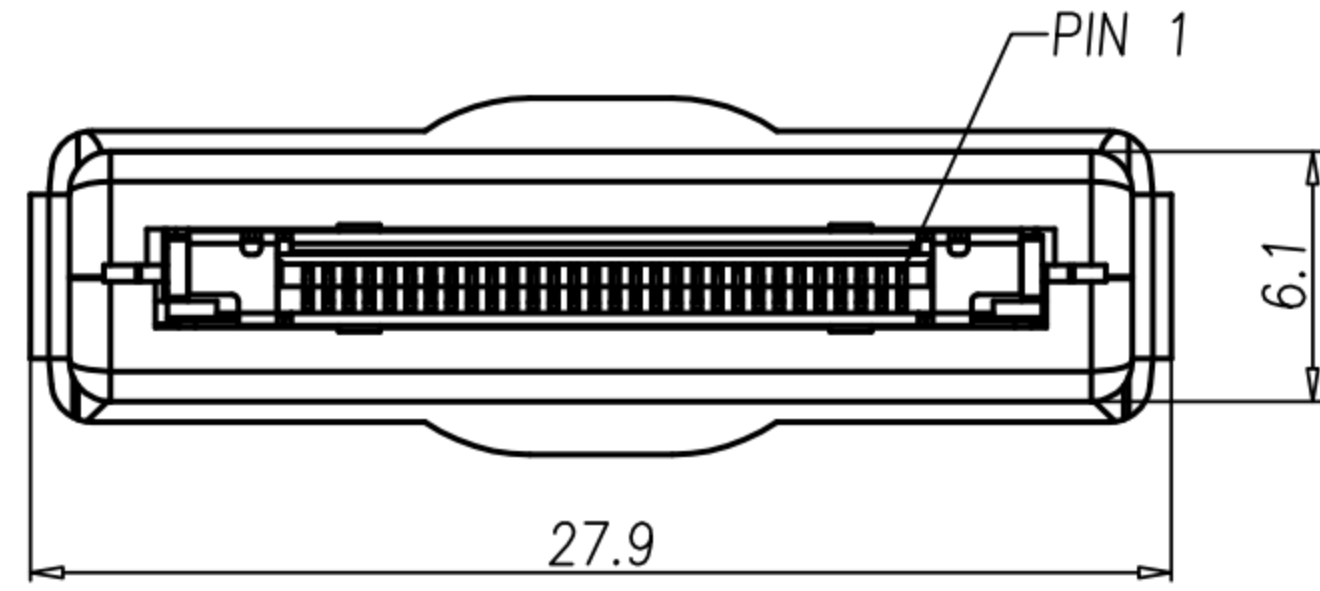

NOTE:
 1.MATERIAL:
 1-1.CONTACT:PHOSPHOR BRONZE.
 1-2.METAL UPPER-CAP: STAINLESS STEEL.
 1-3.METAL LOWER-CAP: STAINLESS STEEL.
 1-4.CABLE FIXED: BRASS.
 1-5.HOUSING: NYLON 46.
 1-6.PLASTIC UPPER CAP: COLOR SEE TABLE A
 1-7.PLASTIC LOWER-CAP: COLOR SEE TABLE A
 1-8.SR: PVC.
 2.PLATING:
 2-1.CONTACT: SEE TABLE A
 2-2.CABLE FIXED: TIN 50u".
 2-3.METAL DOWN-CAP: NICKEL 60u".

TABLE A

PC-30M2-15	NATURE WHITE	BRIGHT TIN 60u"	GOLD 5u"	NATURE WHITE
PC-30M2-14	NATURE BLACK	BRIGHT TIN 60u"	GOLD 5u"	NATURE BLACK
PC-30M2-10	NATURE BLACK	GOLD FLASH	GOLD 5u"	NATURE BLACK
PC-30M2-08	NATURE WHITE	GOLD FLASH	GOLD 5u"	NATURE WHITE
PC-30M2-07	NATURE BLACK	GOLD FLASH	GOLD 5u"	NATURE BLACK
P/N	HOUSING COLOR	SOLDER PLATING	CONTACT PLATING	CAP COLOR

DRAWN	Jen Xie	APP'D	Fido Weng	UNIT	mm	TOLERANCE			TITLE	SEE TABLE A			SHEET	1
CHK'D	Emily Suen	SCALE	1:1	ANGULA	±1°	PART NO.			SEE TABLE A	DWG NO.	QC2560	VERSION	C	