

CUSTOMER DRAWING

REV.	DESCRIPTION	APPVL. BY	DATE	ECN NO.
A	RELEASE	Emily Suen	10/07/12"	
B	CHANGE MATERIAL	Emily Suen	19/09/22"	
C				

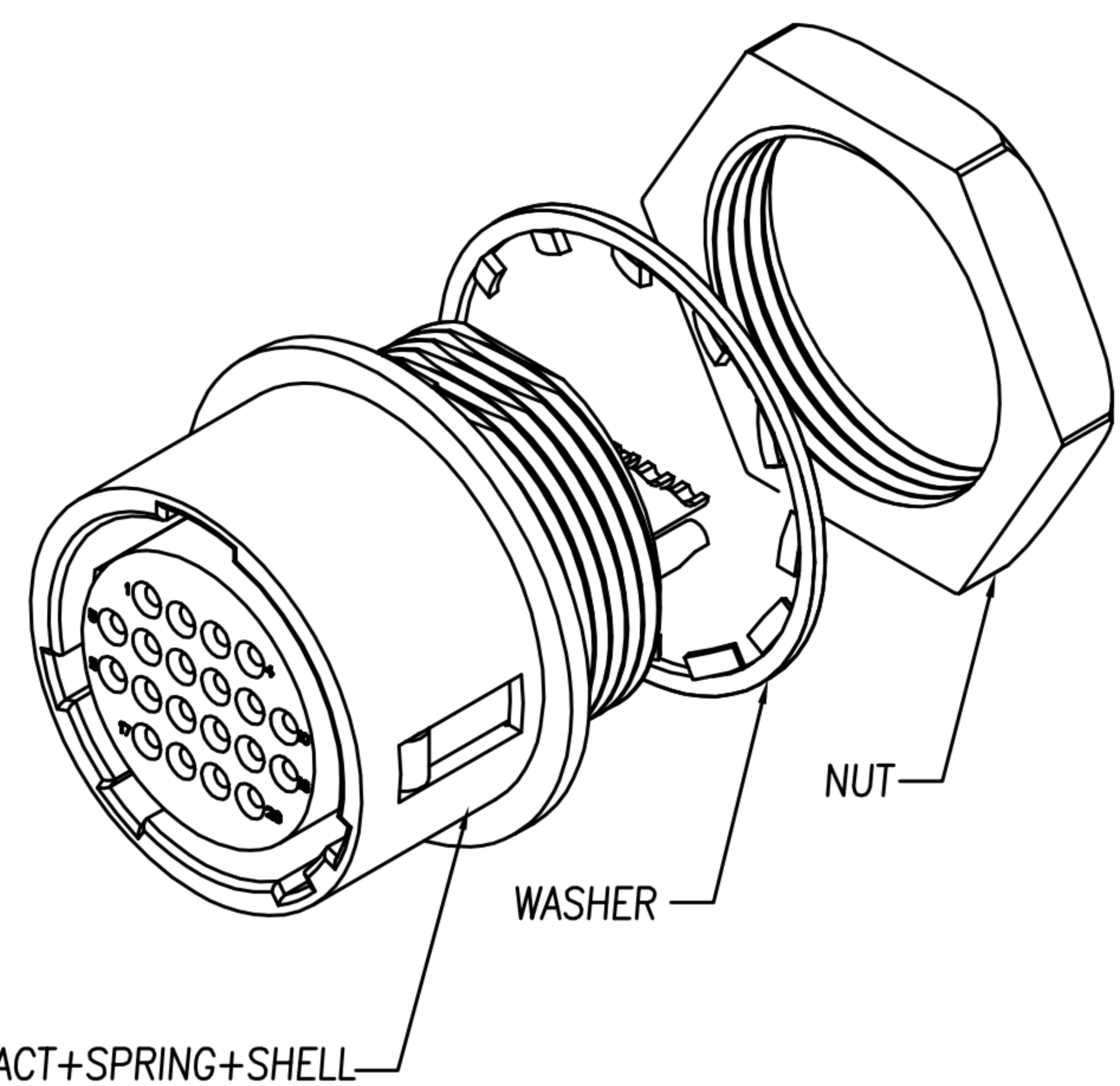
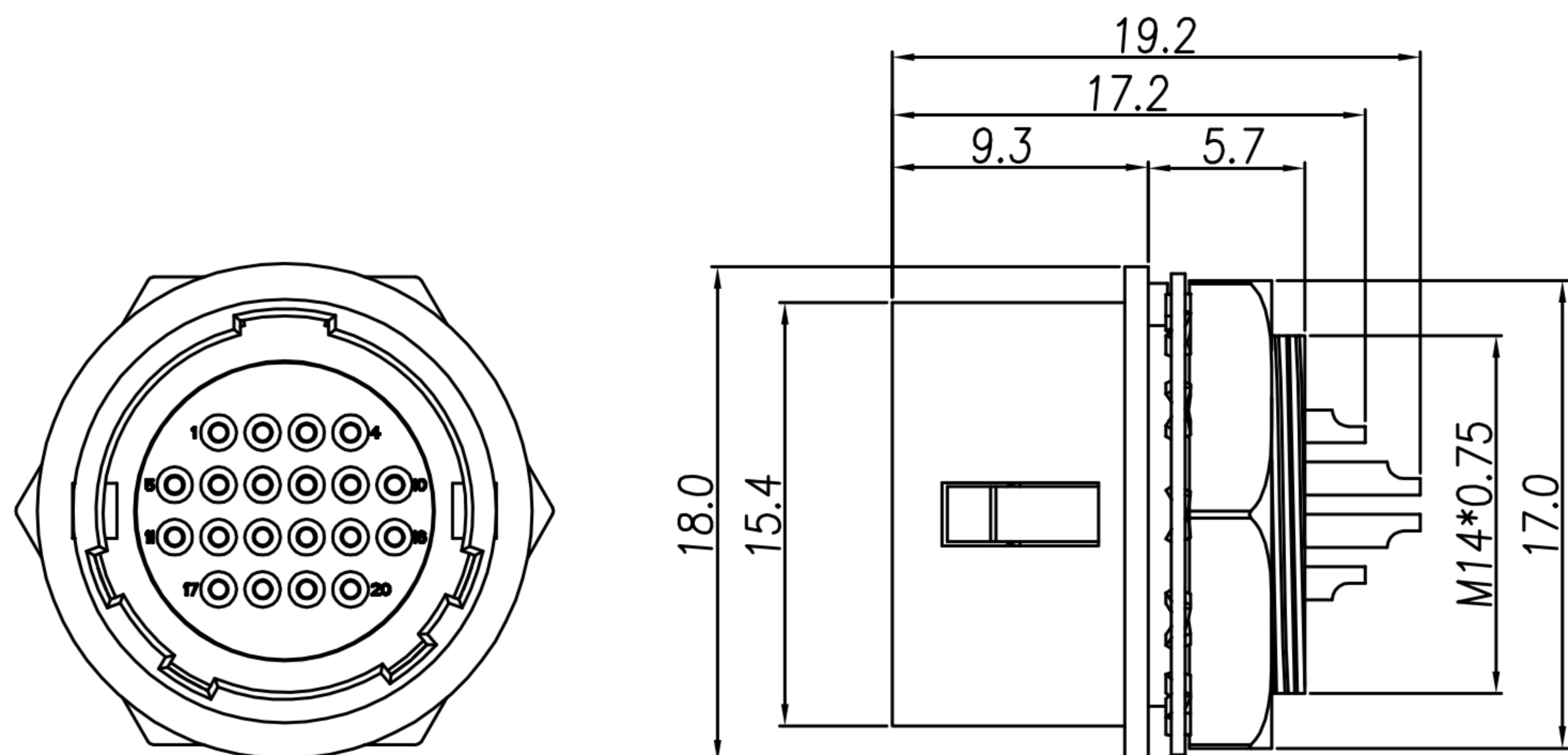

1. MATERIAL :

- △ 1-1. HOUSING : NYLON66 UL94V-0; COLOR : BLACK
- 1-2. CONTACT : BRASS
- 1-3. SHELL : ZINC ALLOY
- 1-4. SPRING : STAINLESS STEEL
- 1-5. WASHER : PHOSPHOR BRONZE
- 1-6. NUT : BRASS

2. FINISH :

- 2-1. CONTACT : GOLD FLASH
- 2-2. SHELL : NICKEL
- 2-3. WASHER : NICKEL
- 2-4. NUT : NICKEL

3. ELECTRICAL SPECIFICATION :

- 3-1. Rated current : 2A
- 3-2. Rated voltage : 100V AC / 140V DC

4. Environmental :

- 4-1. Operation Temperature : -25℃~85℃

DRAW	Lai Angus	APPVL	Emily Suen	UNIT	mm	TOLERANCE			TITLE	DIN 20PIN(F) RECEPTACLE 圆形/矩形式(SHELL SIZE 13mm)			SHEET	
CHECK	Emily Suen			SCALE	1:1	.x ±0.20 .xx ±0.15 .xxx ±0.05 .xxxx ±0.03 ANGULA ±1°			PART NO.	DI-20F2-02	DWG NO.	QC5836	VERSION	