

CUSTOMER DRAWING

REV.	DESCRIPTION	APPROVED BY	DATE	ECN NO.
△A	RELEASE	Ku Chou	27/06/24'	
△B				
△C				

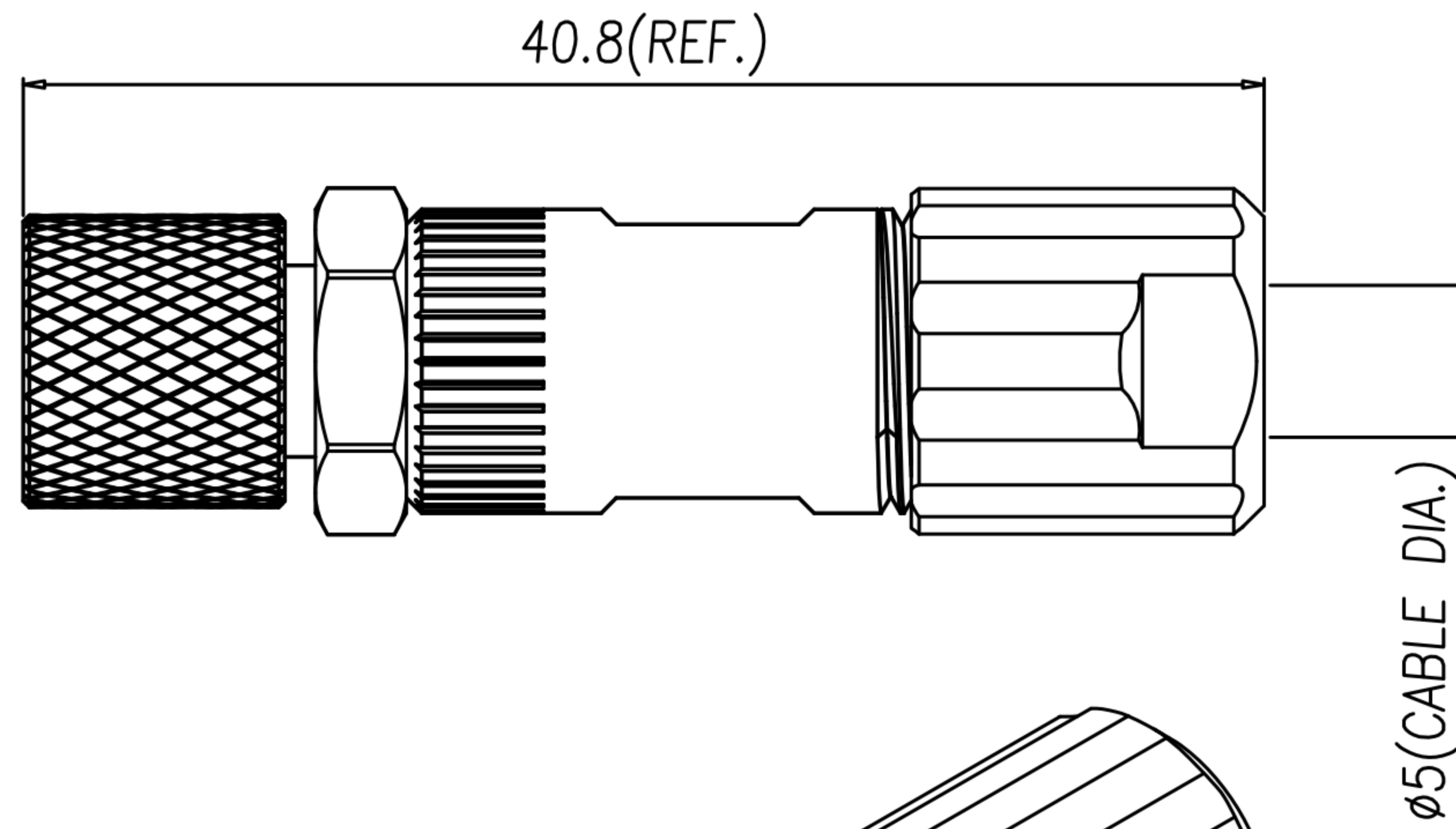

WP-04F2-313-11	WP-03F2-185-11	WP-02F2-119-11

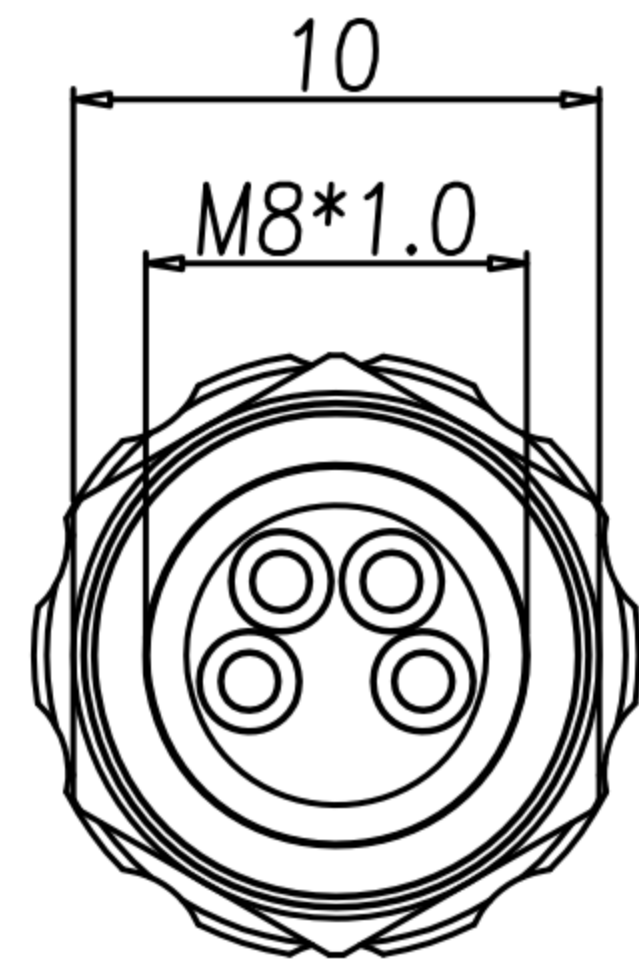
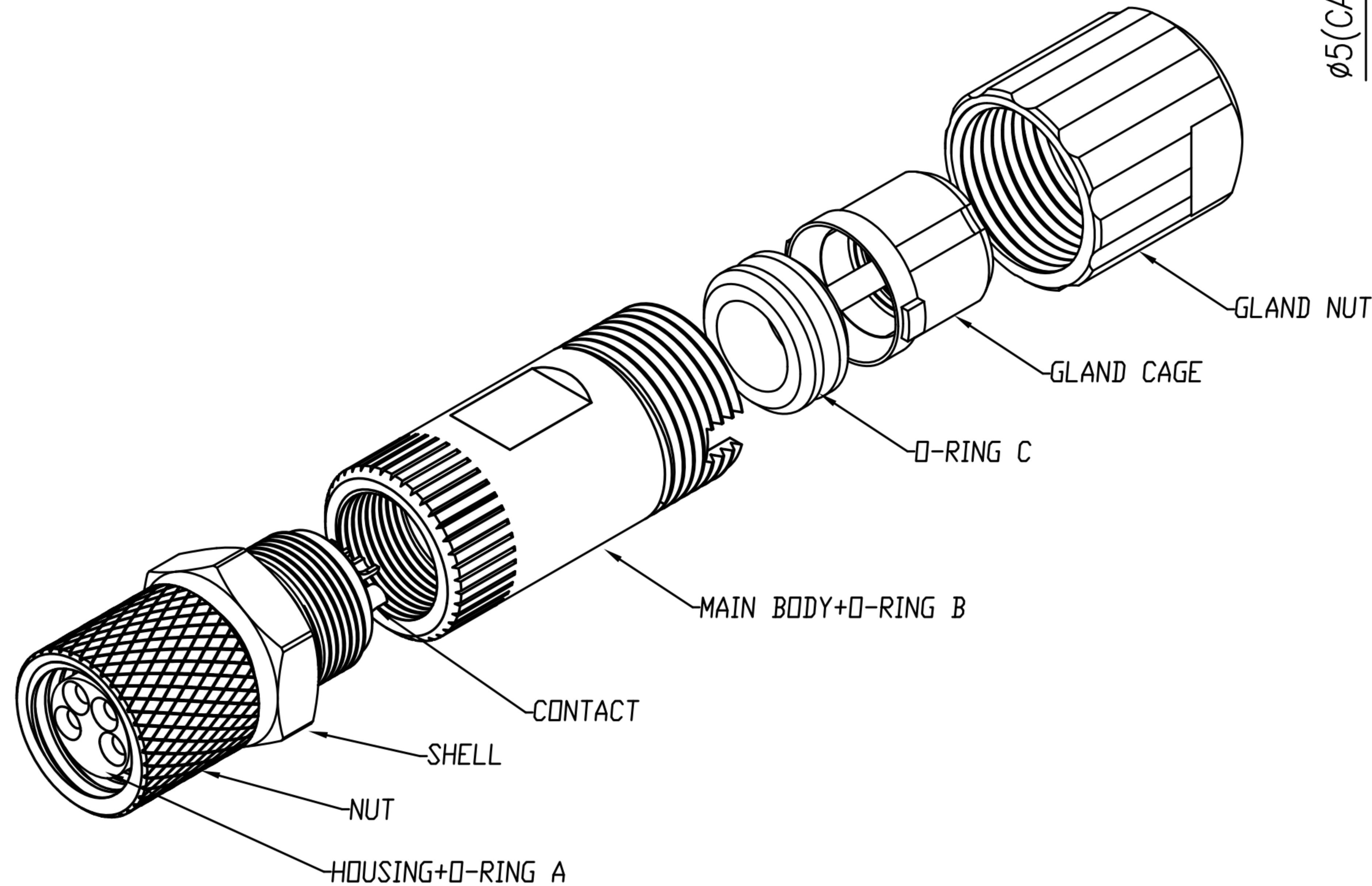

1. MATERIAL :
 - 1-1. MATERIAL A
 - a. HOUSING : PBT UL94V-0 ; COLOR : BLACK.
 - b. CONTACT : BRASS
 - c. NUT : BRASS
 - d. SHELL : ALUMINIUM ALLOY
 - e. O-RING A : NBR ; COLOR : BLACK
 - 1-2. MATERIAL B
 - a. MAIN BODY : ALUMINIUM ALLOY
 - b. O-RING B : EPDM ; COLOR : BLACK
 - 1-3. O-RING C : NBR COLOR : BLACK.
 - 1-4. GLAND CAGE : PA66 ; COLOR : WHITE.
 - 1-5. GLAND NUT : PA66 ; COLOR : BROWN.
2. FINISH :
 - 2-1. MATERIAL A
 - a. CONTACT : GOLD FLASH PLATED.
UNDER PLATE : NICKEL.
 - b. NUT : NICKEL PLATED.
 - c. SHELL : NICKEL PLATED.
 - 2-2. MAIN BODY : NICKEL PLATED.
3. ELECTRICAL SPECIFICATION :
 - 3-1. Rated current : 4A
 - 3-2. Rated voltage : 60V
 - 3-3. Water proof : IPX7
4. Environmental :
 - 4-1. Operation Temperature : -40℃~85℃

DRAWN	Emily Suen	APP'D	Ku Chou	UNIT	mm	TOLERANCE		广东科斯达电子科技有限公司 GUANG DONG KE SI DA ELECTRONIC TECHNOLOGY CO., LTD.	TITLE	M8 (F) Assembly type (NUT L=8.6)			SHEET	1/1
CHK'D	Ku Chou			SCALE	1:1	.x ±0.20 .xx ±0.10 .xxx ±0.05 .xxxx ±0.03 ANGULA ±1°			PART NO.	SEE TABLE A	DWG NO.	QC11018	VERSION	A