

REV.	DESCRIPTION	APPVL. BY	DATE	ECN NO.	
A	RELEASE	LED	14/05/21'		
B					
C					

CUSTOMER DRAWING

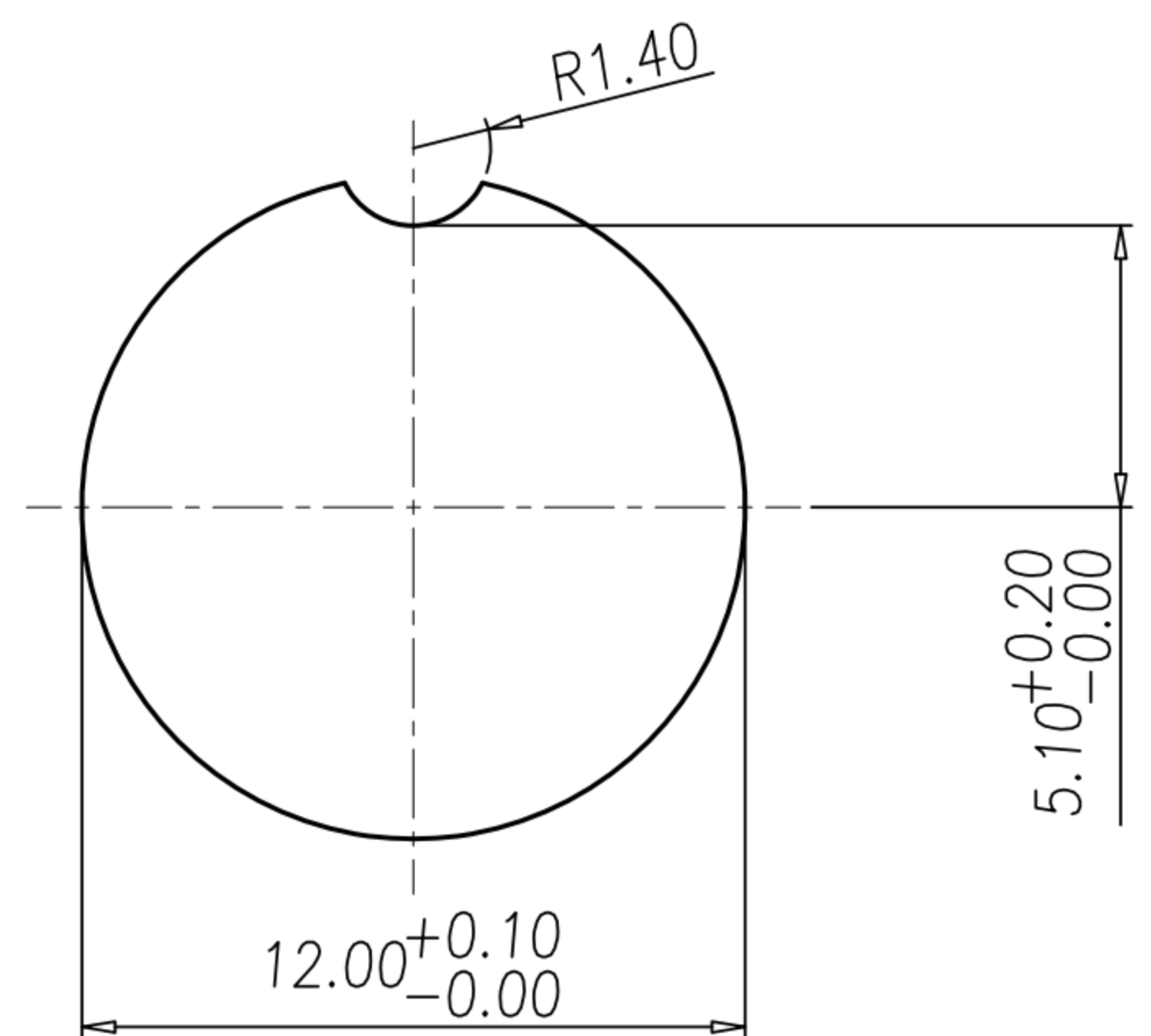
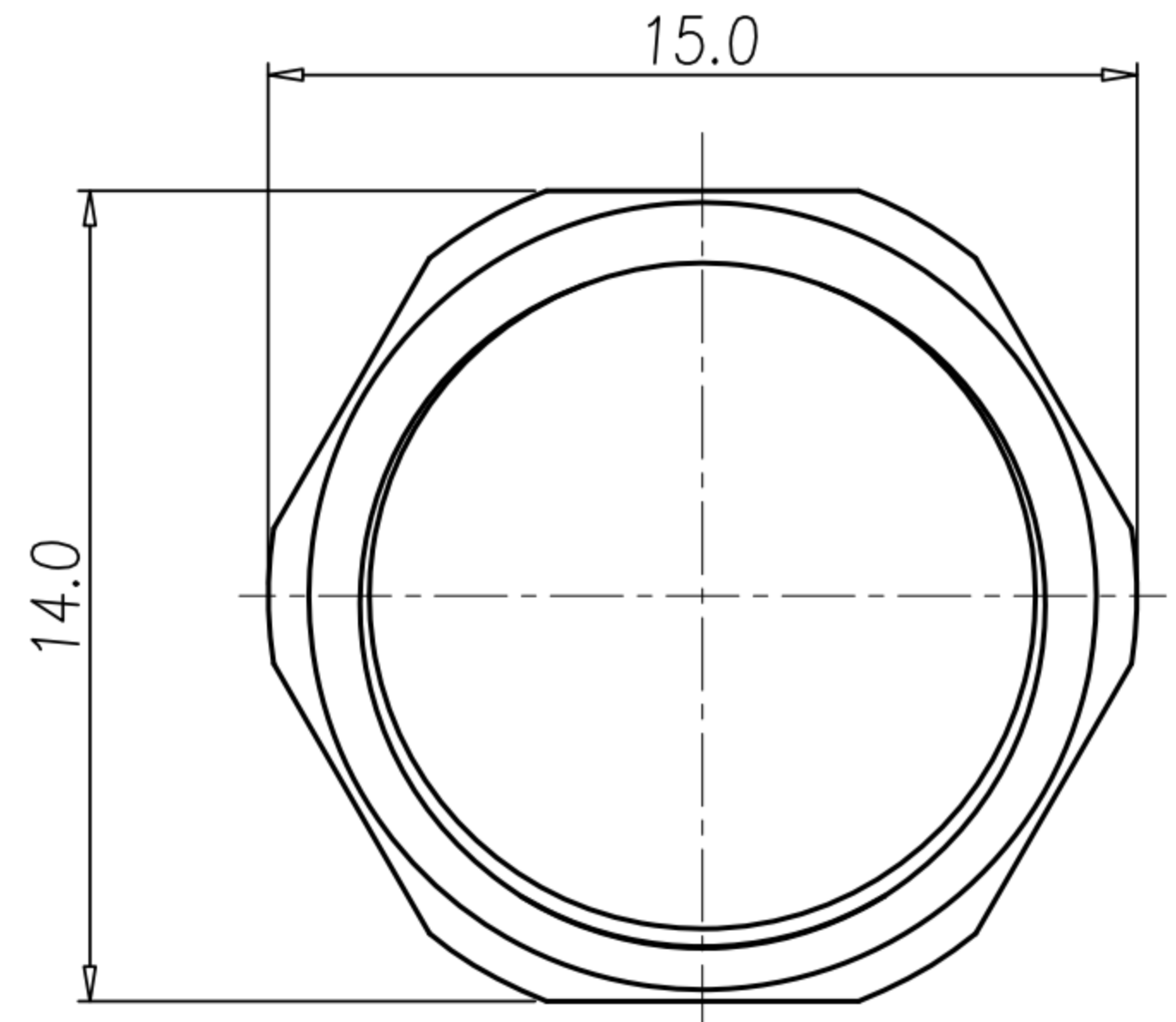
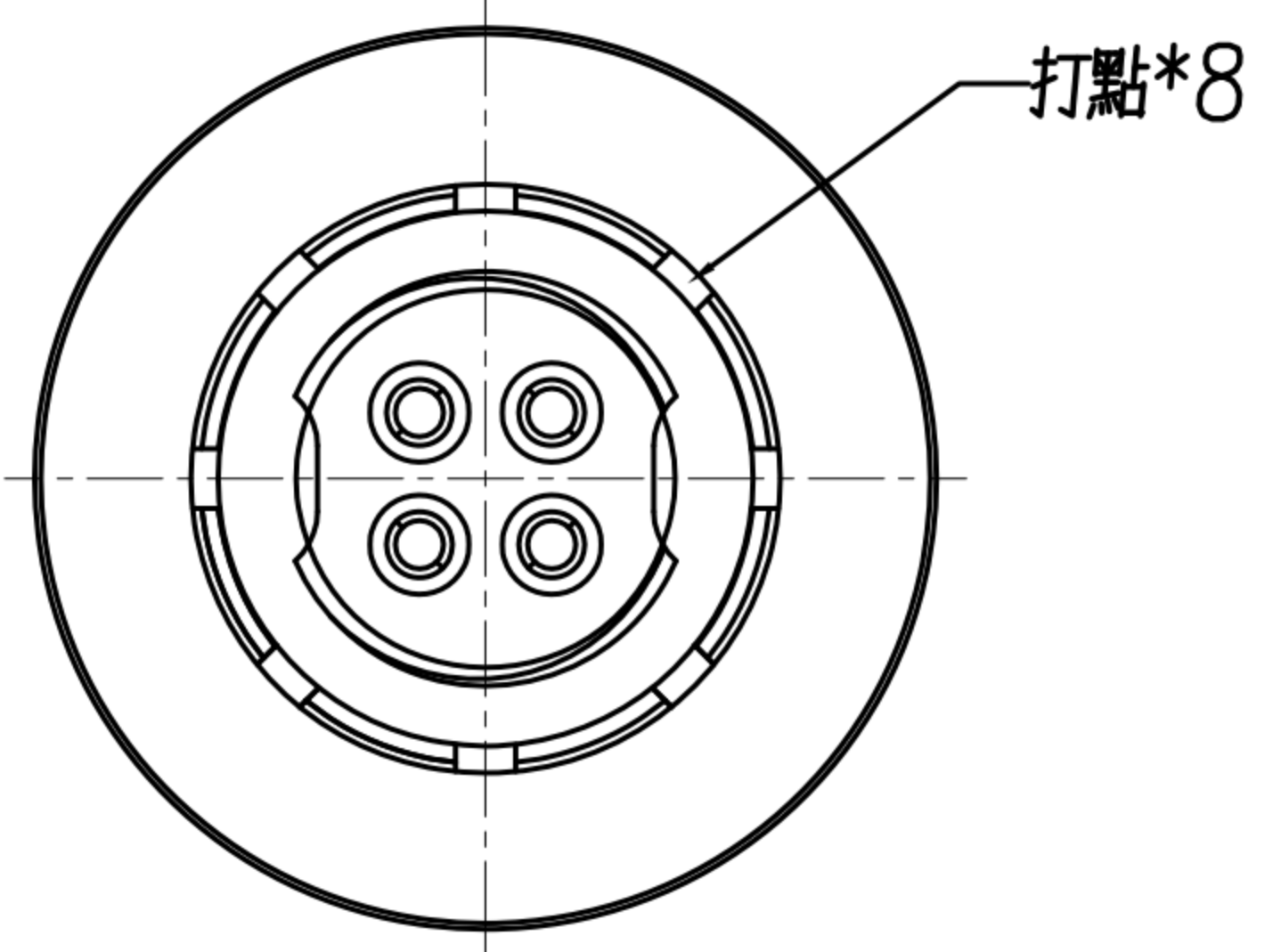
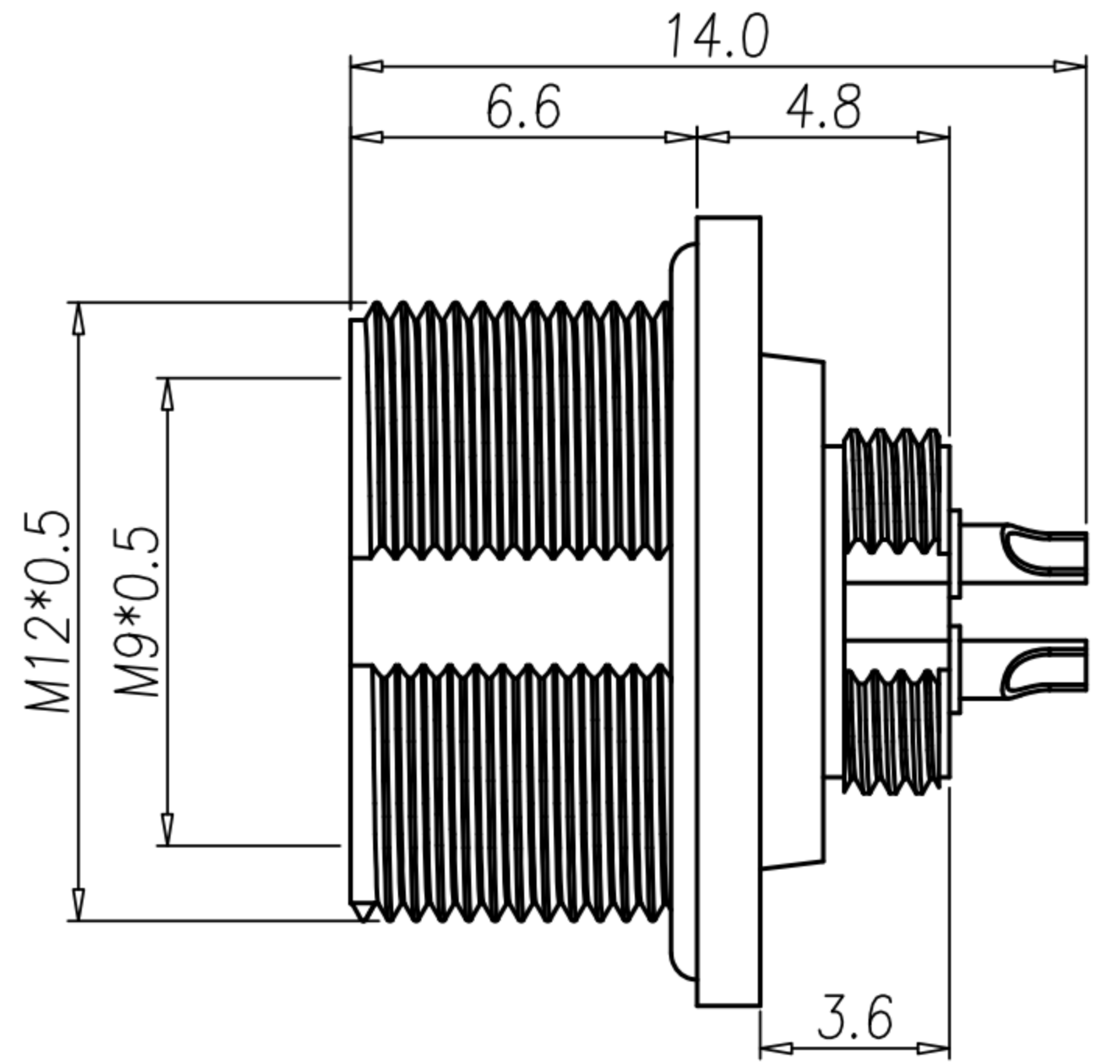
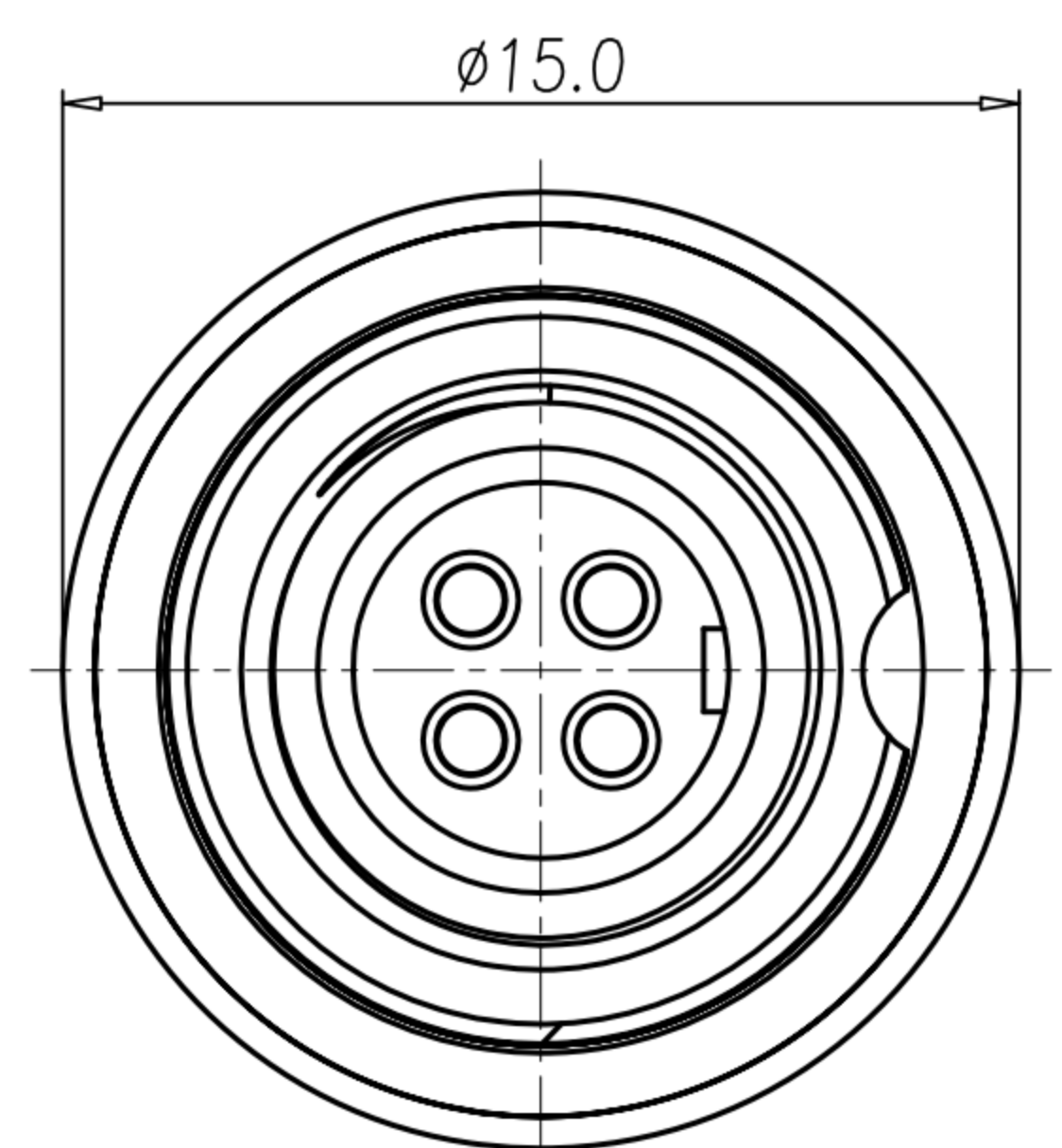

- MATERIAL :
  - 1-1. HOUSING : PA UL94V-0 ; COLOR : BLACK
  - 1-2. CONTACT : BRASS.
  - 1-3. SHELL : BRASS.
  - 1-4. O-RING A : SILICONE ; COLOR : BLACK.
  - 1-5. O-RING B : EPDM ; COLOR : BLACK.
  - 1-6. NUT : BRASS
- FINISH :
  - 2-1. CONTACT : GOLD FLASH
  - 2-2. SHELL : NICKEL PLTAE D.
  - 2-3. NUT : NICKEL PLTAE D.
- ELECTRICAL SPECIFICATION :
  - 3-1. Rated current(40°C) : 2~3P 4A; 4~5P 3A; 7~8P 1A
  - 3-2. Rated Voltage : 125V
  - 3-3. Water proof : IP67
- Environmental :
  - 4-1. Operation Temperature : -40°C~85°C

NUT

RECOMMEND PANEL CUT-OUT

WP-02F2-100-11	WP-03F2-169-11	WP-04F2-279-11	WP-05F2-212-11	WP-07F2-21-11	WP-08F2-132-11

DRAWN	LED	APP'D	Ku Chou	UNIT	mm	TOLERANCE		广东科斯达电子科技有限公司 GUANG DONG KE SI DA ELECTRONIC TECHNOLOGY CO., LTD.	TITLE	WP M9 (F) M12 插頭 測試			SHEET
CHK'D	Ku Chou			SCALE	1:1	.x ±0.20 .xx ±0.10 .xxx ±0.05 .xxxx ±0.03 ANGULA ±1°			PART NO.	SEE TABLE A	DWG NO.	QC10196	VERSION