

CUSTOMER DRAWING

REV.	DESCRIPTION	APPROVED BY	DATE	ECN NO.
△A	RELEASE	Fido Weng	25/04/17*	
△B				
△C				

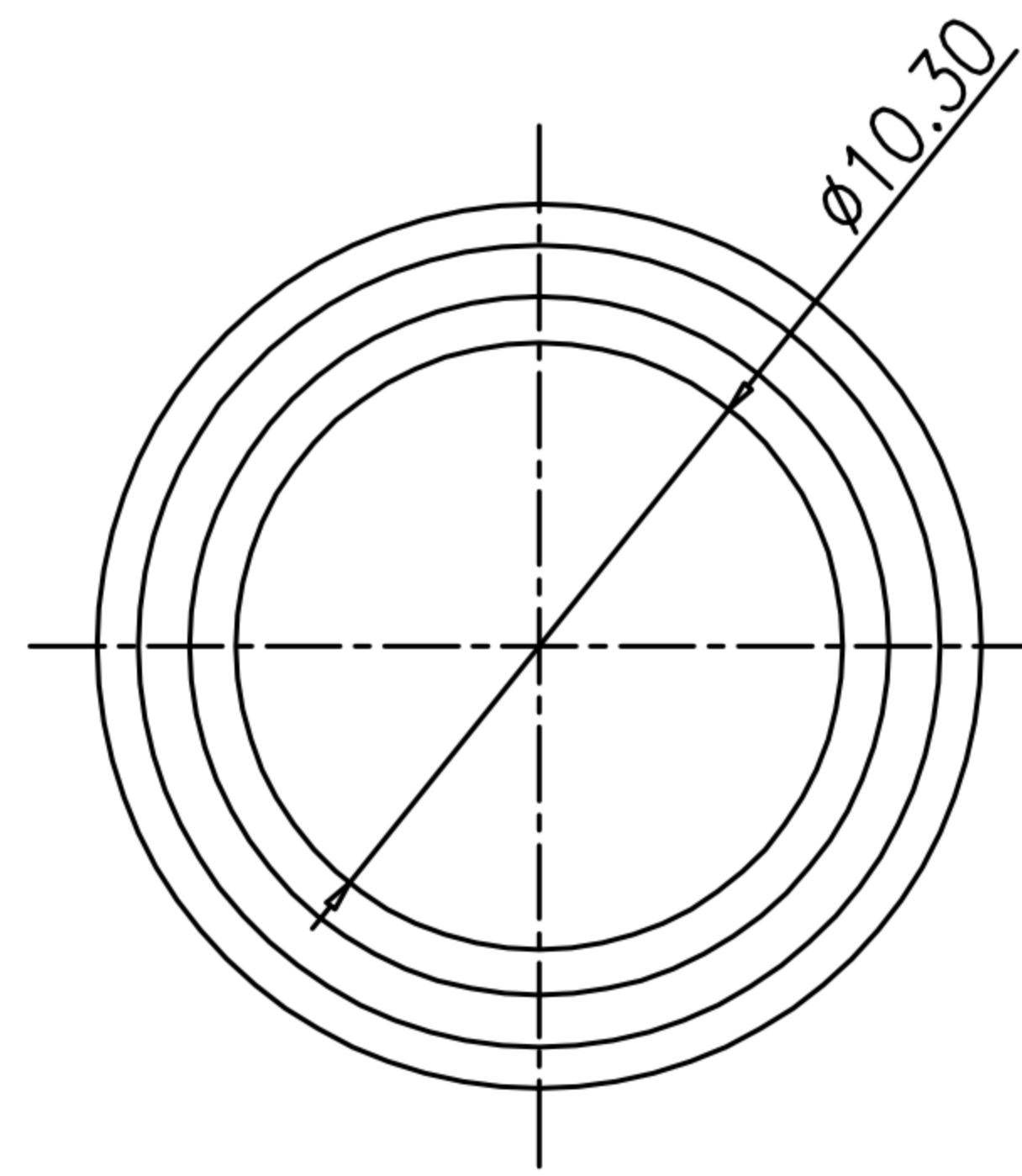
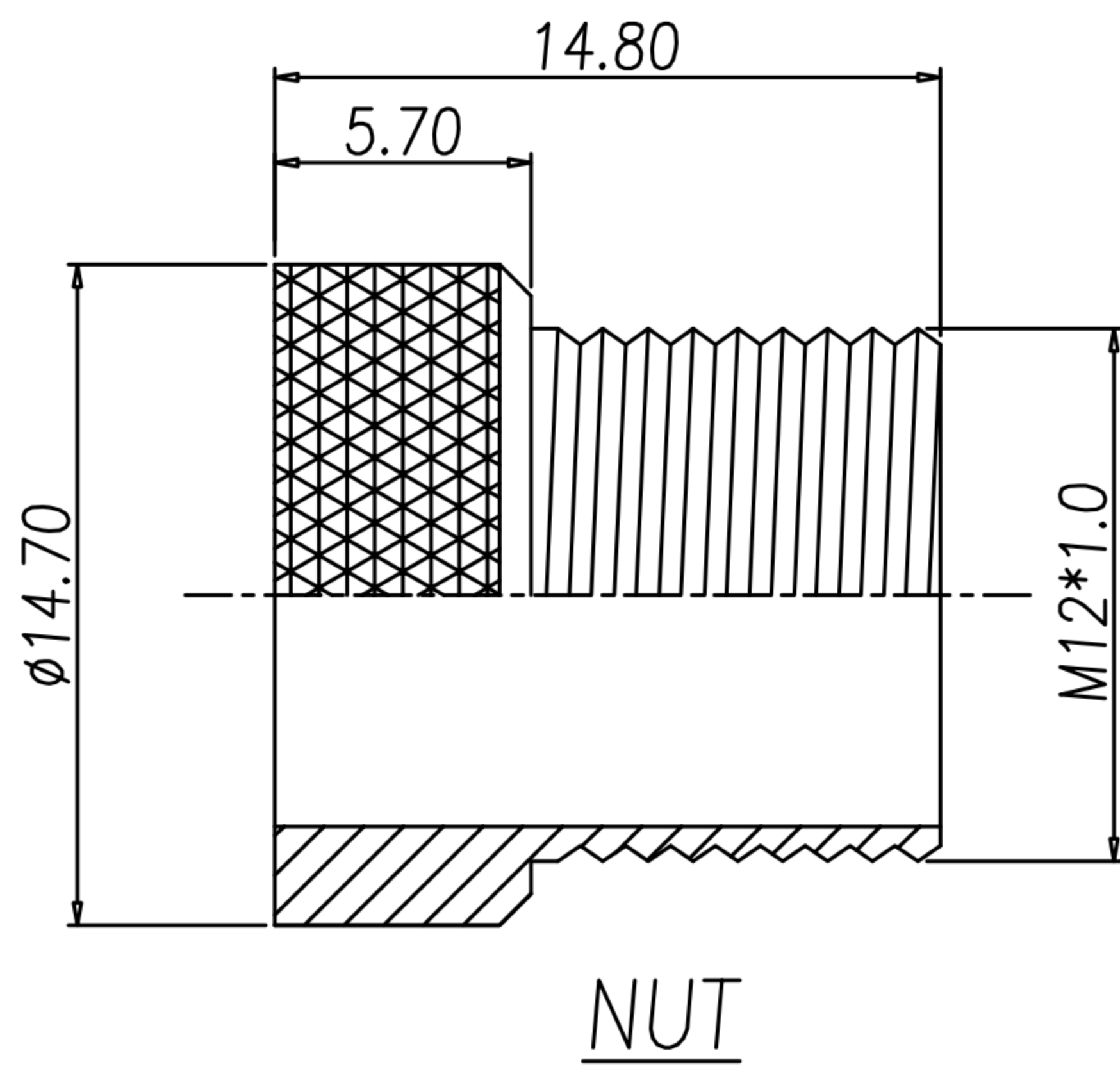
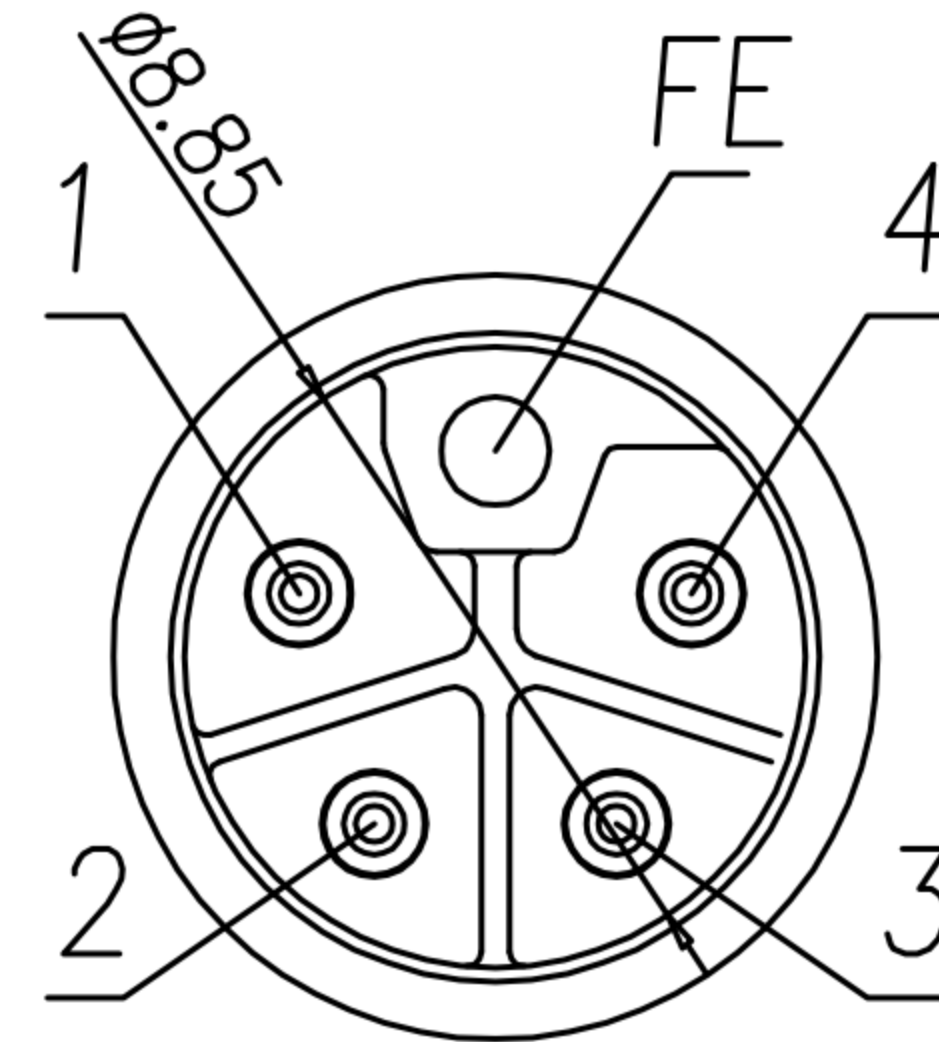
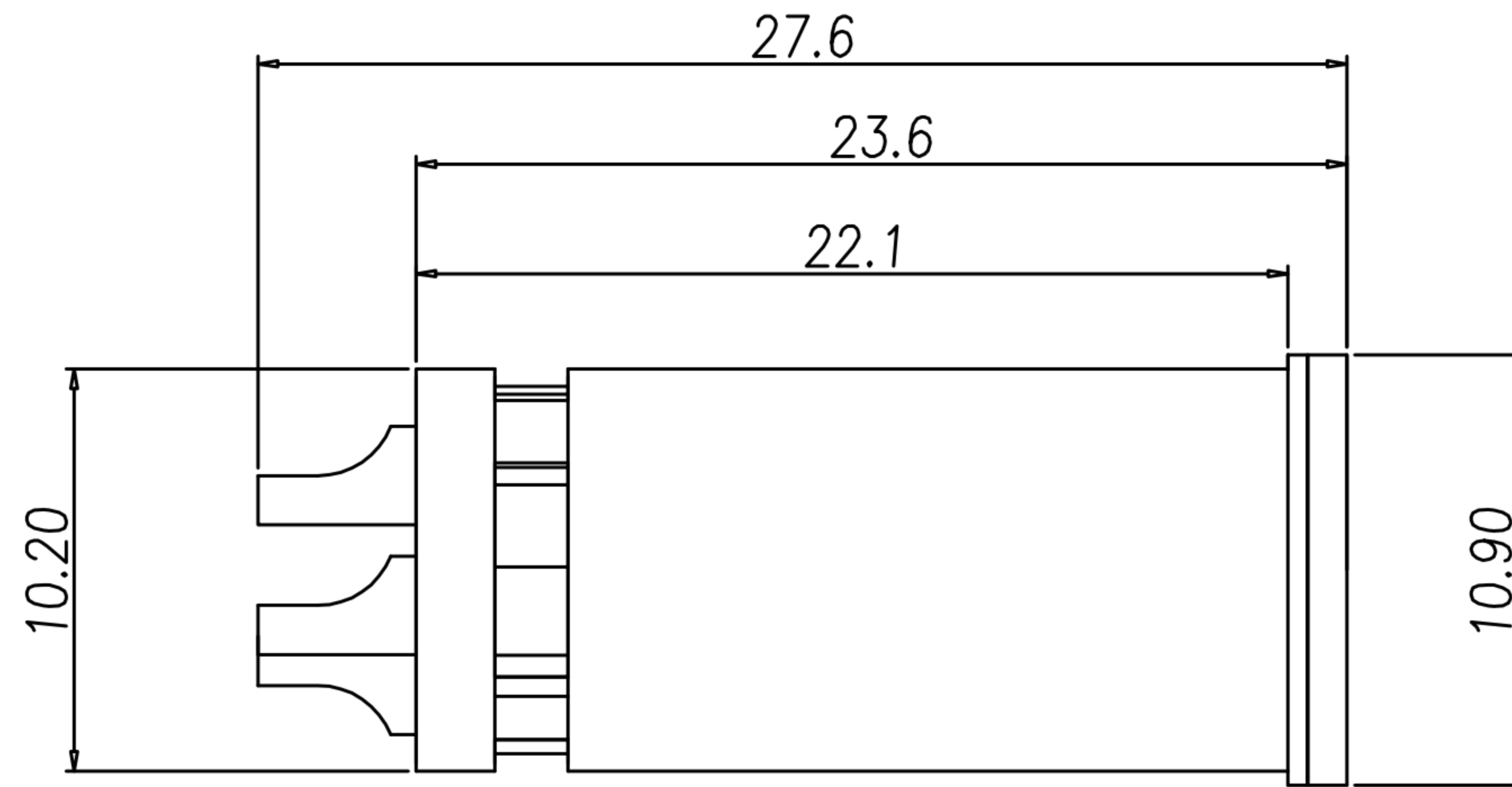

1. MATERIAL :
 - 1-1. HOUSING : PA66 UL94V-0 ; COLOR : BLACK
 - 1-2. CONTACT : BRASS
 - 1-3. NUT : BRASS
 - 1-4. SHELL : BRASS
2. FINISH :
 - 2-1. CONTACT : 10 MICRO INCHES MIN. GOLD PLATED
UNDER PLATE : NICKEL
 - 2-2. NUT : NICKEL PLATED
 - 2-3. SHELL : BRIGHT TIN PLATED
3. ELECTRICAL SPECIFICATION :
 - 3-1. Rated current : 16A
 - 3-2. Rated Voltage : 63V
 - 3-3. Water proof: IP67/68
4. Environmental :
 - 4-1. Operation Temperature : -40℃~105℃

DRAWN	KU	APPEND	Ku Chou	UNIT	mm	TOLERANCE		广东科斯达电子科技有限公司 GUANG DONG KE SI DA ELECTRONIC TECHNOLOGY CO., LTD.	TITLE	M12-5PIN (4+FE) L-CODE (M) 成形焊線式			SHEET	1 VERSION A
CHKED	Emily Suen			SCALE	1:1	.x ±0.20 .xx ±0.10 .xxx ±0.05 .xxxx ±0.03 ANGULA ±1°			PART NO.	WP-05M2-119-11	DWG NO.	QC7937		