

CUSTOMER DRAWING

REV.	DESCRIPTION	APPROVED BY	DATE	ECN NO.
△A	RELEASE	Fido Weng	24/07/17*	
△B				
△C				

# ASSEMBLY INSTRUCTION

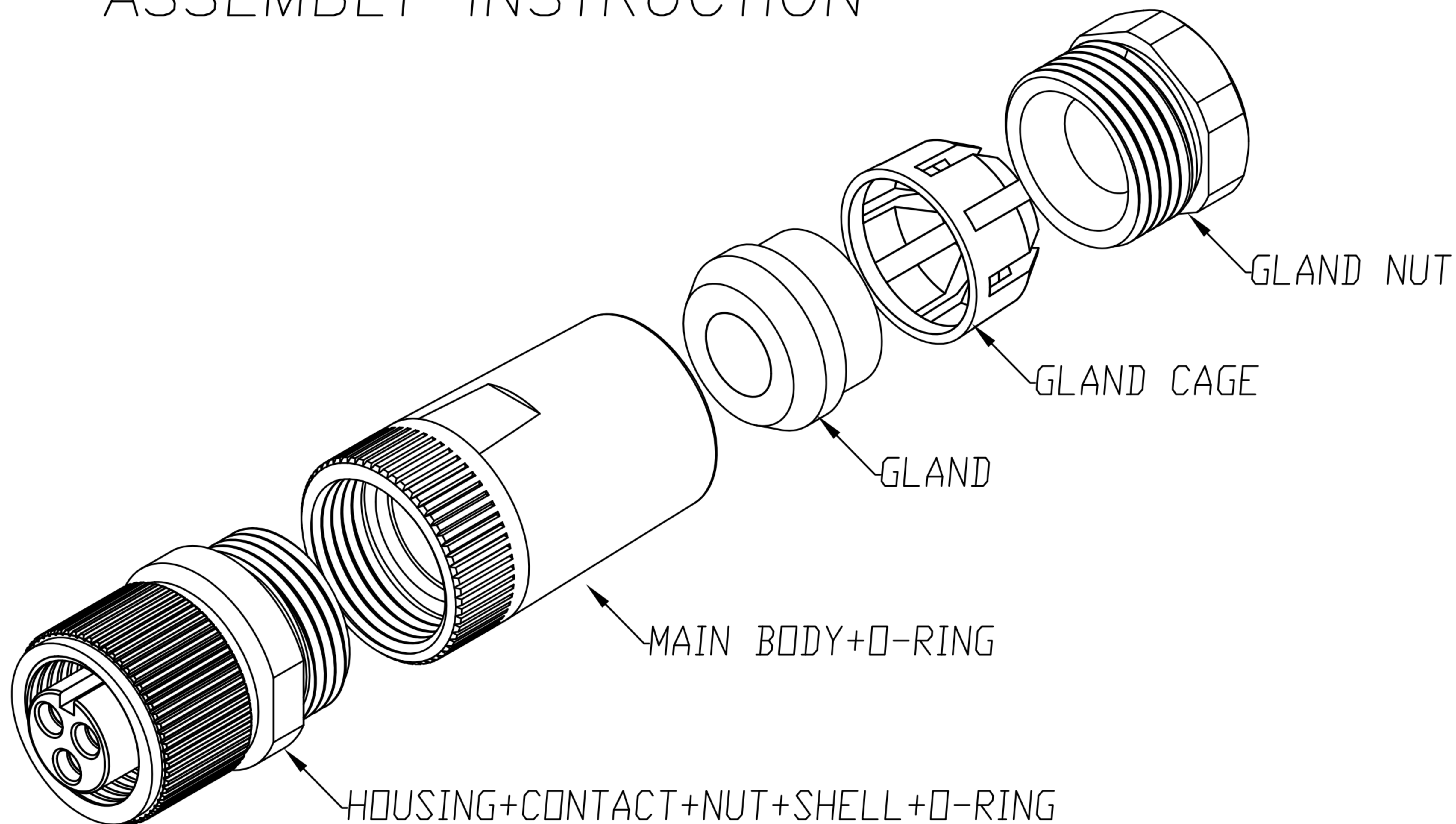

DRAWN	KU Chou	APP'D		UNIT	mm	TOLERANCE		广东科斯达电子科技有限公司 GUANG DONG KE SI DA ELECTRONIC TECHNOLOGY CO., LTD.	TITLE	M12 (F) A-coded Assembly type (15A)			SHEET	2/2
CHK'D				SCALE	1:1	.x ±0.20 .xx ±0.10 .xxx ±0.05 .xxxx ±0.03 ANGULA ±1°			PART NO.	SEE TABLE A	DWG NO.	QC8683	VERSION	A



CUSTOMER DRAWING

REV.	DESCRIPTION	APPROVED BY	DATE	ECN NO.
A	RELEASE	Fido Weng	24/07/17'	
B				
C				

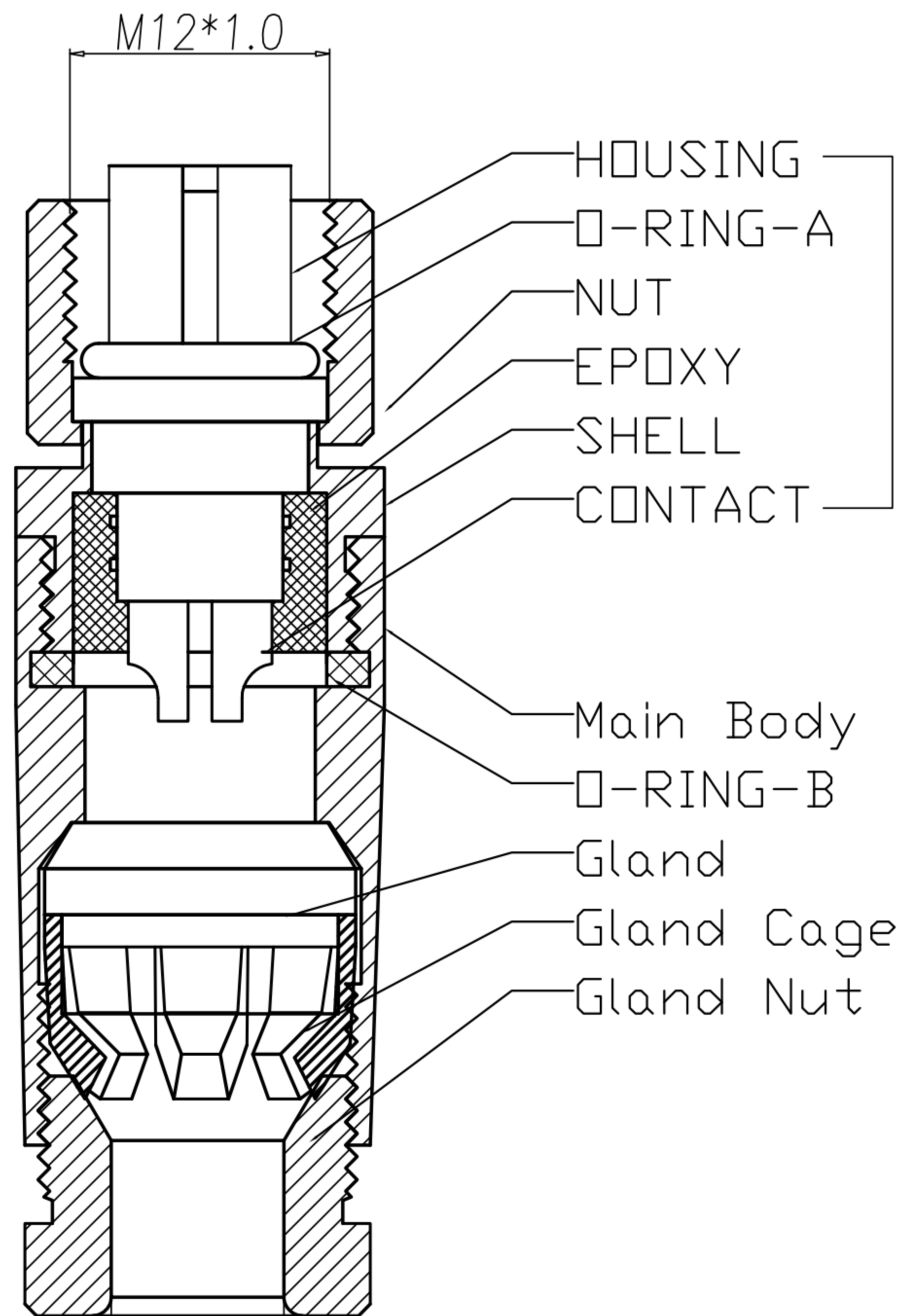
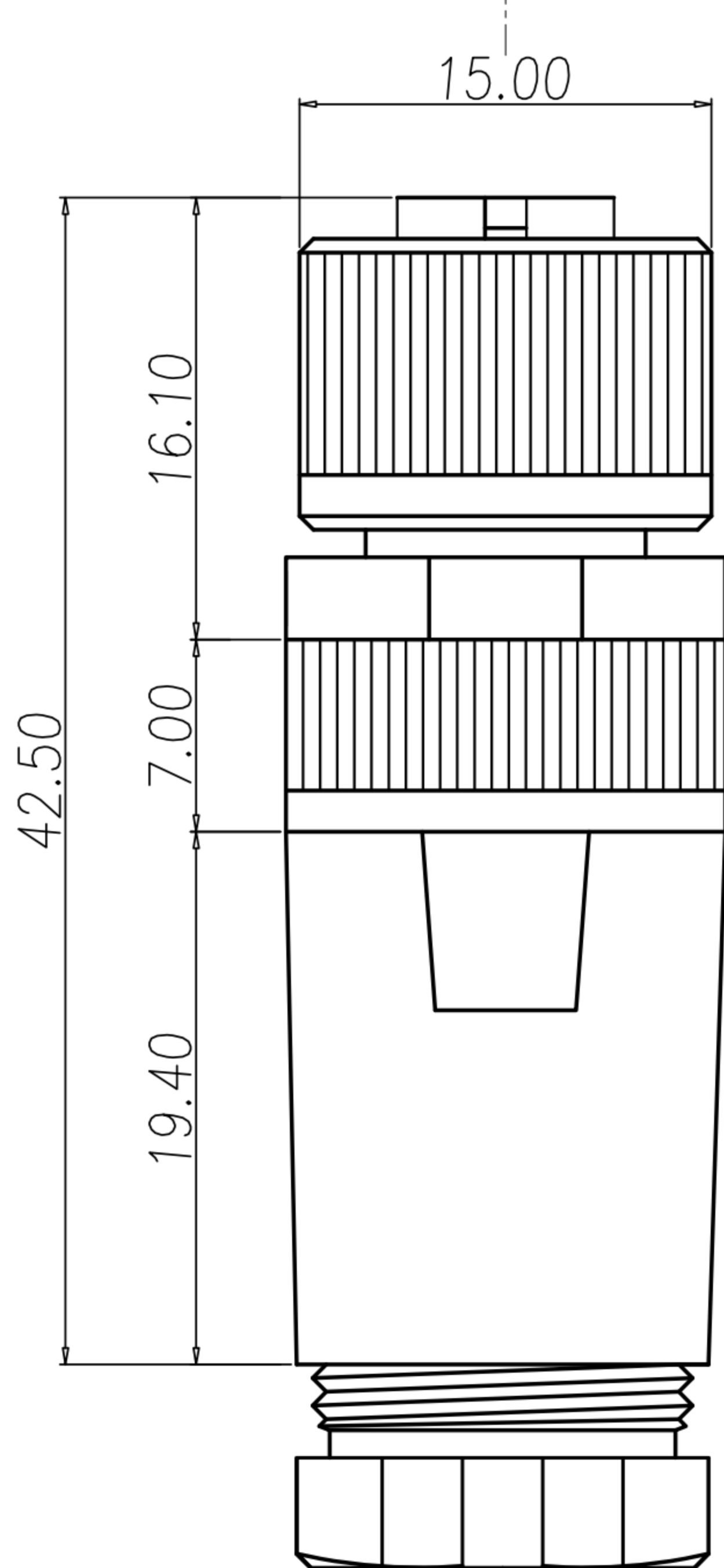
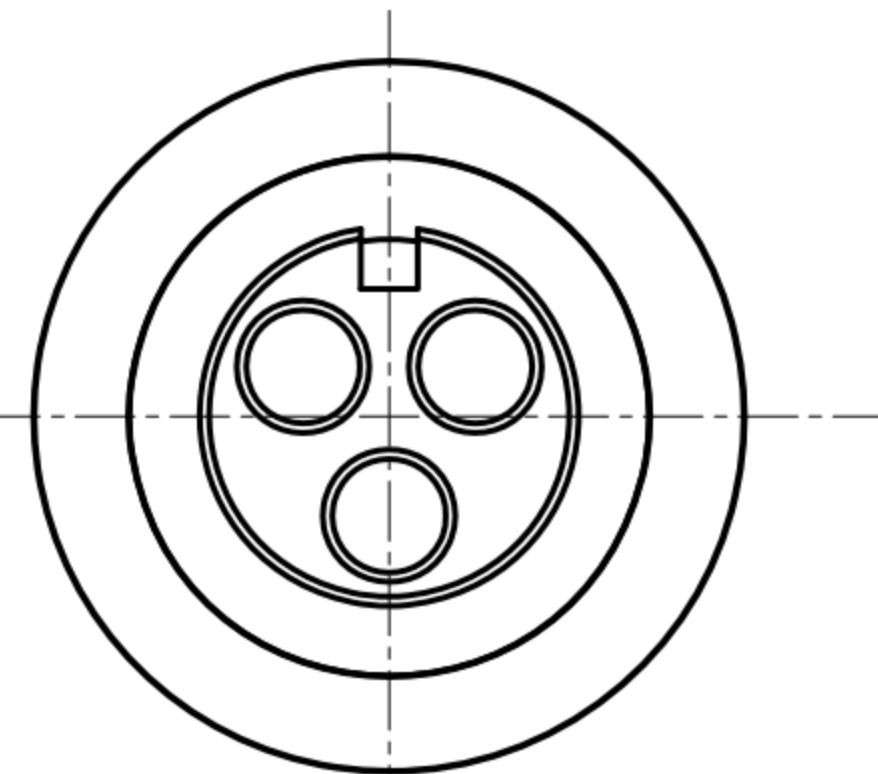

7.50 RECOMMEND CABLE OD=5.0mm~6.0mm

TABLE A

WP-03F2-100-11	WP-02F2-58-11

1. MATERIAL :

1-1.

- a. HOUSING : PBT UL94V-0 ; COLOR : BLACK.
- b. CONTACT : BRASS
- c. NUT : ALUMINUM ALLOY
- d. SHELL : ALUMINUM ALLOY
- e. O-RING : EPDM ; COLOR : BLACK

1-2. Main Body : ALUMINUM ALLOY

1-3. Gland : SILICONE COLOR : BLACK.

1-4. Gland Cage : POM ; COLOR : WHITE.

1-5. Gland Nut : ALUMINUM ALLOY

2. FINISH :

2-1.

- a. CONTACT : GOLD FLASH.
- b. NUT : SATING Ni PLATED.
- c. SHELL : SATING Ni PLATED.

2-2. Main Body : SATING Ni PLATED.

2-3. Gland Nut : SATING Ni PLATED.

3. ELECTRICAL SPECIFICATION :

3-1. Rated current : 15A

3-2. Rated Voltage : 250V

3-3. Water proof : IPX7

4. Environmental :

4-1. Operation Temperature : -20℃~85℃

DRAWN	KU Chou	APP'D	UNIT	mm	TOLERANCE		广东科斯达电子科技有限公司 GUANG DONG KE SI DA ELECTRONIC TECHNOLOGY CO., LTD.	TITLE	M12 (F) A-coded Assembly type (15A)			SHEET	1/2
CHK'D			SCALE	1:1	.x ±0.20 .xx ±0.10 .xxx ±0.05 .xxxx ±0.03 ANGULA ±1°			PART NO.	SEE TABLE A	DWG NO.	QC8683	VERSION	A