

CUSTOMER DRAWING

REV.	DESCRIPTION	APPVL. BY	DATE	ECN NO.
△A	RELEASE	Fido Weng	18/02/14*	
△B				
△C				

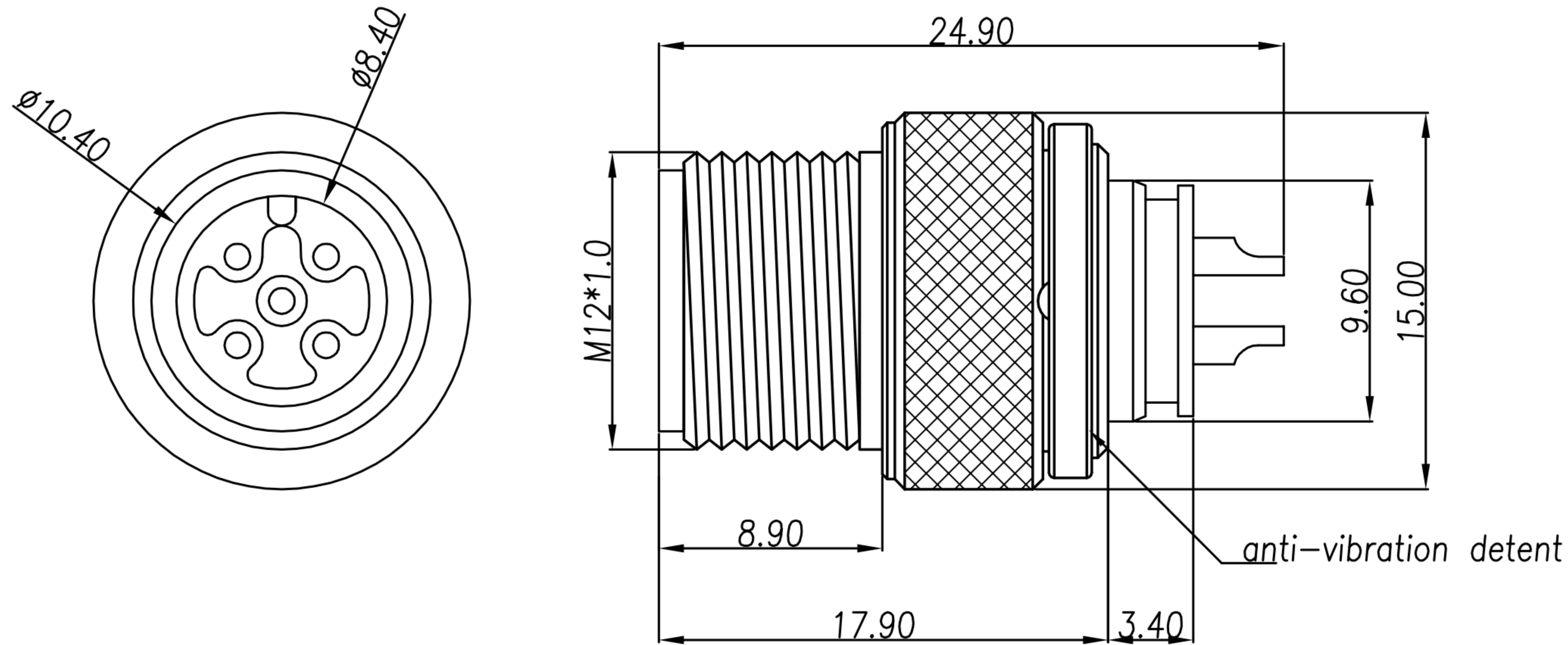

WP-05M2-79-11	WP-05M2-88-11	WP-04M2-141-11	WP-03M2-80-11
WP-05M2-111-11			

- MATERIAL :
 - 1-1. HOUSING : PA66 ; COLOR : BLACK
 - 1-2. CONTACT : BRASS
 - 1-3. NUT : SEE TABLE A
- FINISH :
 - 2-1. CONTACT : SEE TABLE A
 - 2-2. SHELL : SEE TABLE A
- ELECTRICAL SPECIFICATION :
 - 3-1. Rated current : 4A
 - 3-2. Rated Voltage : 3~4PIN 250V ; 5PIN 60V
 - 3-3. Water proof : IP68
- Environmental :
 - 4-1. Operation Temperature : -40°C~105°C

TABLE A/表A

WP-03M2-80-11	BRASS/NICKEL PLATED.	GOLD 10u"
WP-04M2-141-11	BRASS/NICKEL PLATED.	GOLD 10u"
WP-05M2-111-11	BRASS/NICKEL PLATED.	GOLD 10u"
WP-05M2-88-11	STAINLESS STEEL 303.	GOLD FLASH
WP-05M2-79-11	BRASS/NICKEL PLATED.	GOLD FLASH
PART NO.	NUT MATERIAL	CONTACT PLATED