

CUSTOMER DRAWING

REV.	DESCRIPTION	APPROVED BY	DATE	ECN NO.
△A	RELEASE	Fido Weng	08/04/09*	
△B	CHANGE & DIN	Fido Weng	10/12/10*	
△C				

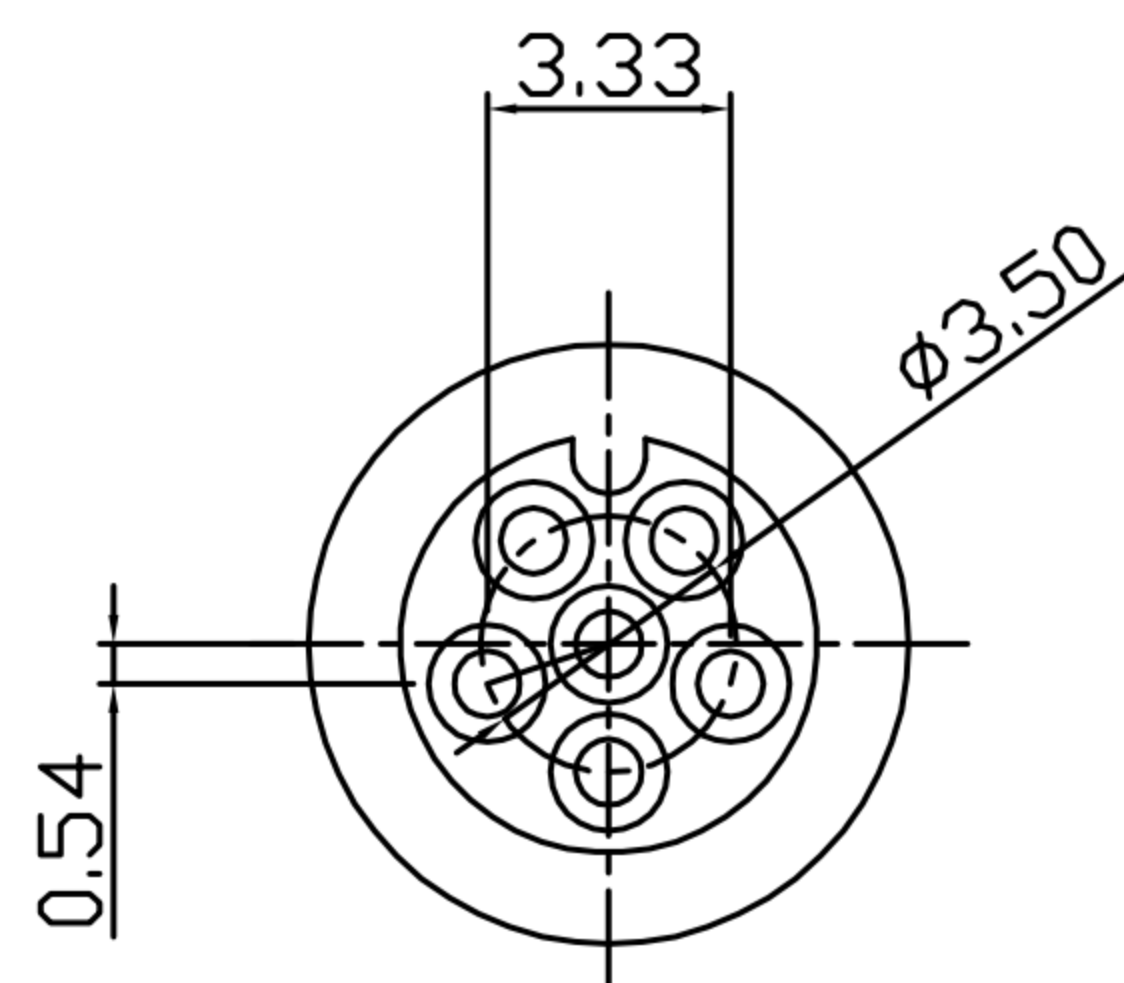
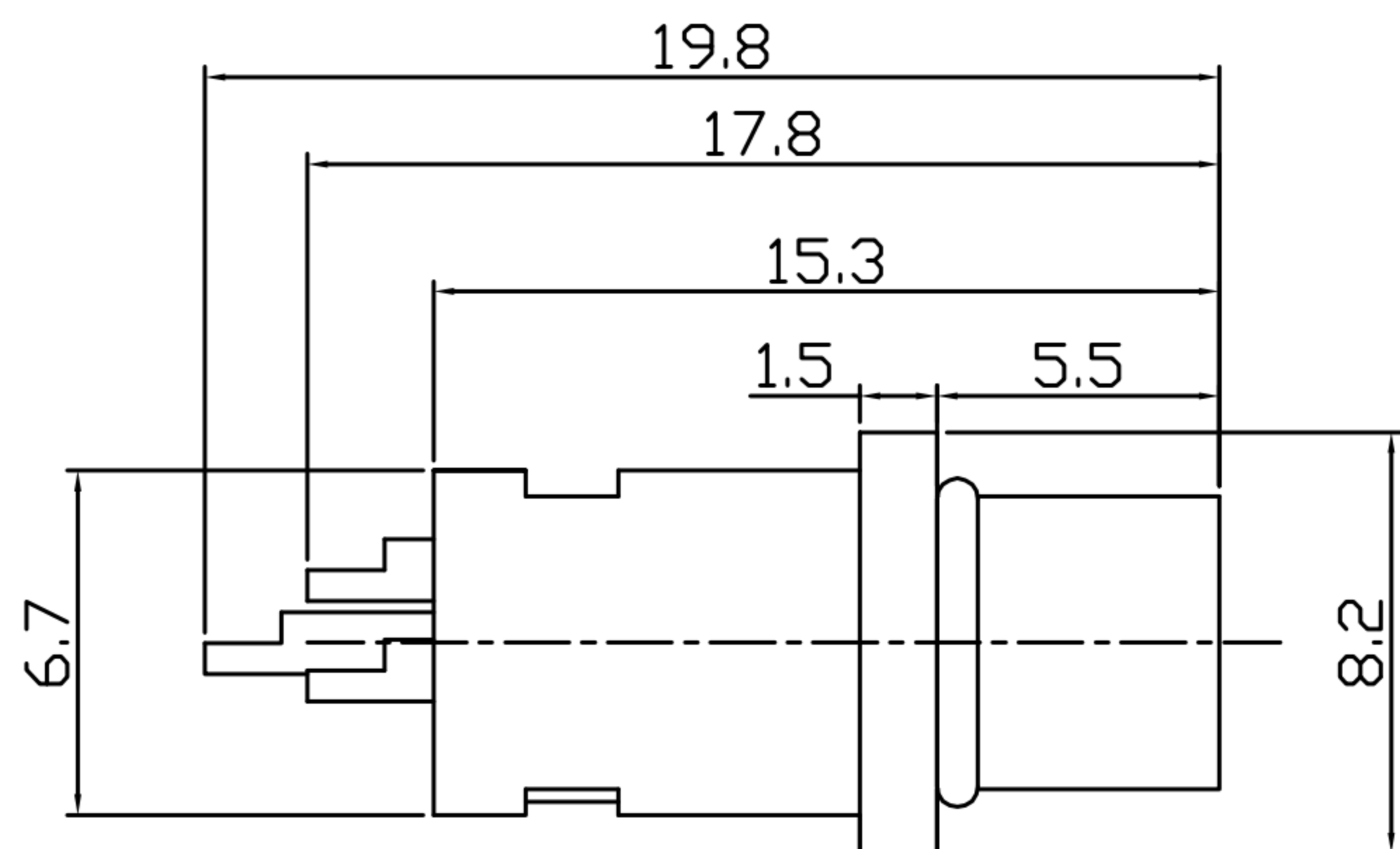
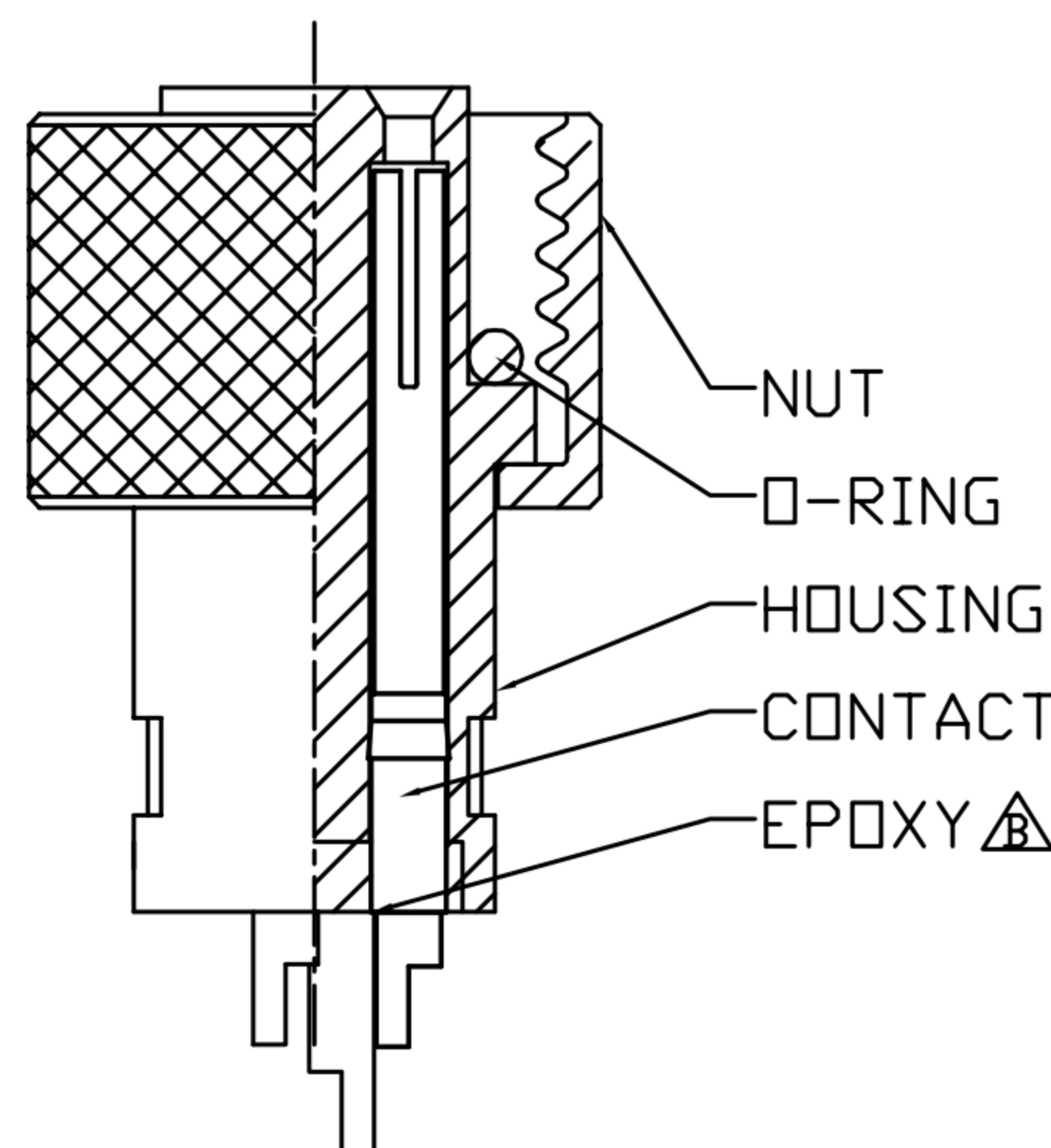
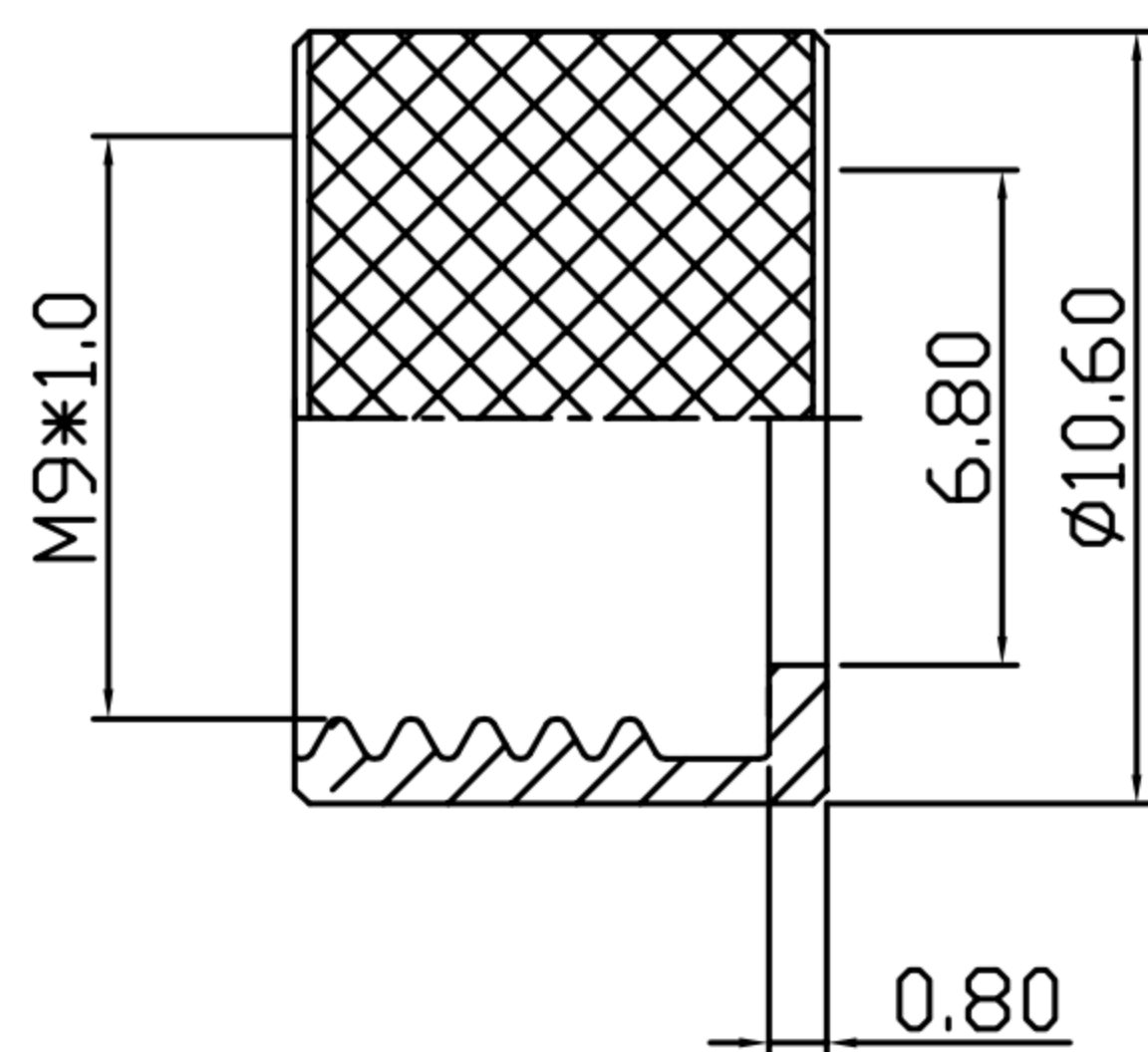
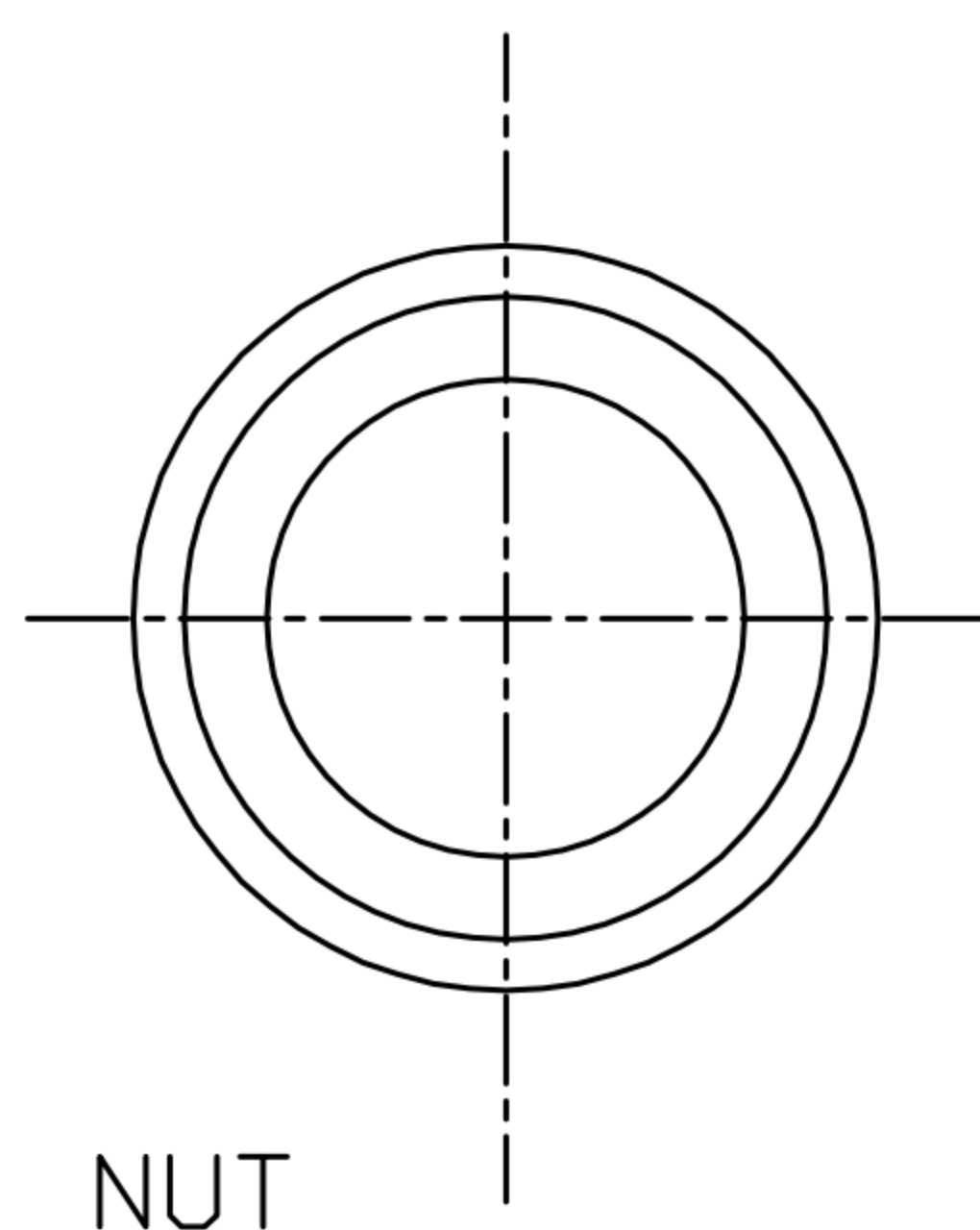

TABLE A

WP-05F2-31 WP-05F2-71	WP-06F2-07
WP-02F2-10	WP-04F2-57
WP-05F2-71	PHOSPHOR BRONZE
WP-06F2-07	BRASS
WP-05F2-31	BRASS
WP-04F2-57	BRASS
WP-02F2-10	BRASS
PART No.	MATERIAL(CONTACT)

- MATERIAL :
  - 1-1. HOUSING : PBT UL94V-0 ; COLOR : BLACK
  - 1-2. CONTACT : SEE TABLE A
  - 1-3. O-RING : NBR ; COLOR : BLACK
  - 1-4. NUT : BRASS
- FINISH :
  - 2-1. CONTACT : 10 MICRO INCHES MIN. GOLD PLATED
  - 2-2. NUT : NICKEL PLATED.
- ELECTRICAL SPECIFICATION :
  - 3-1. Rated current : 4A
  - 3-2. Rated voltage : 60V
  - 3-3. Water proof : IPX7
- Environmental :
  - 4-1. Operation Temperature : -20℃~85℃



DRAWN	Mark Kao	APP'D	KU Chou	UNIT	mm	TOLERANCE		广东科斯达电子科技有限公司 GUANG DONG KE SI DA ELECTRONIC TECHNOLOGY CO., LTD.	TITLE	M9-(F)線端焊線式			SHEET	1
CHK'D	Emily Suen			SCALE	1:1	.x ±0.20 .xx ±0.10 .xxx ±0.05 .xxxx ±0.03 ANGULA ±1°			PART NO.	SEE TABLE A	DWG NO.	QC3690	VERSION	B