

CUSTOMER DRAWING

REV.	DESCRIPTION	APPROVED BY	DATE	ECN NO.
△A	RELEASE	Fido Weng	17/06/09*	
△B	ADD P/N	KU CHOU	15/03/21*	
△C				

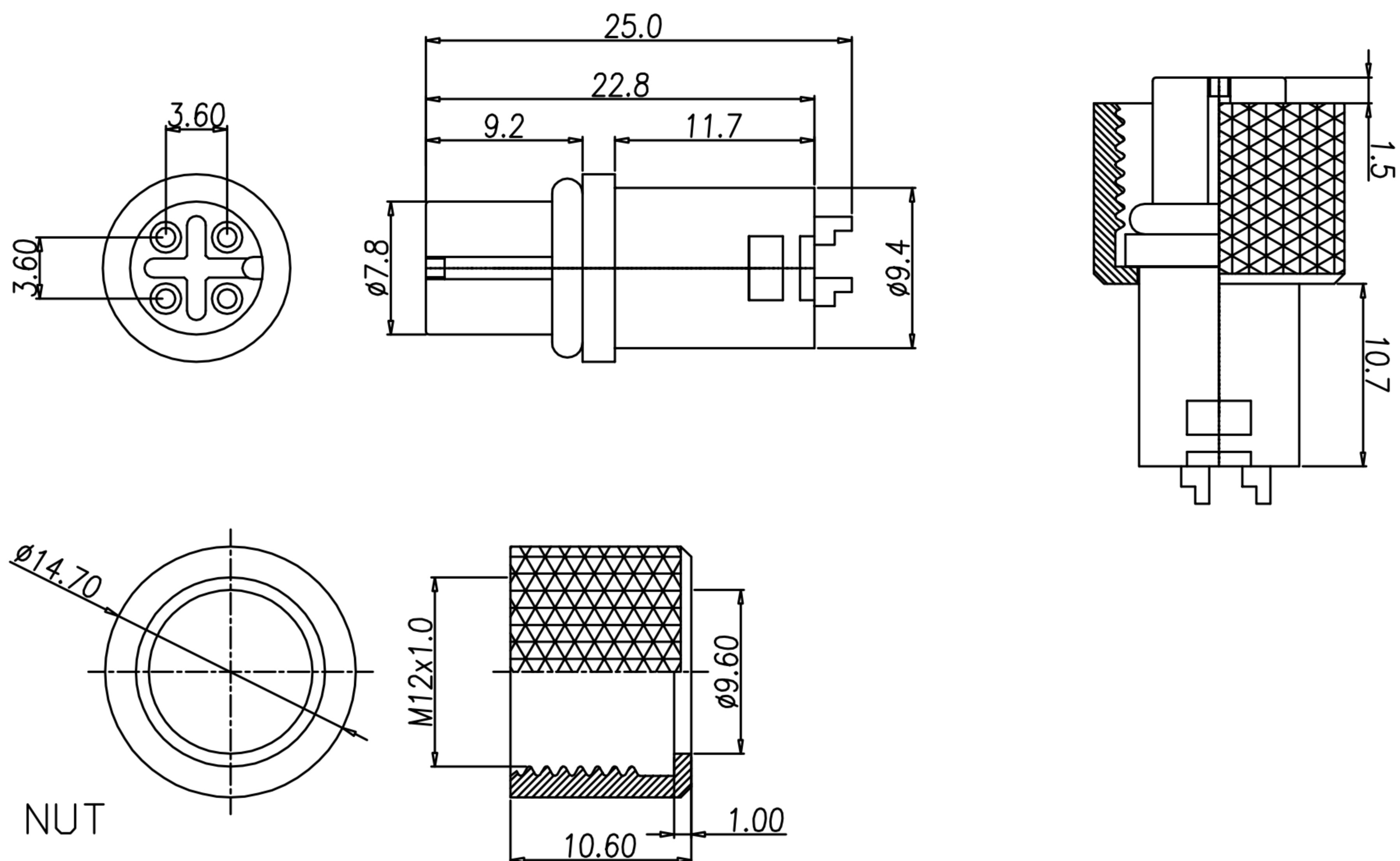

- MATERIAL :
  - HOUSING : PBT UL94V-0 ; COLOR : BLACK
  - CONTACT : BRASS
  - NUT : SEE TABLE A
  - O-RING : EPDM ; COLOR ; BLACK(7.5\*1.5)
- FINISH :
  - CONTACT : SEE TABLE A ; UNDER PLATE : NICKEL
  - NUT : SEE TABLE A
- ELECTRICAL SPECIFICATION :
  - RATED CURRENT: 4A
  - RATED VOLTAGE : 2~4PIN 250V ; 5PIN 60V
  - WATER PROOF: IP67
- ENVIRONMENTAL :
  - OPERATION TEMPERATURE : -40℃~85℃

TABLE A

WP-02F2-36-11 WP-02F2-95-11	WP-02F2-23-11 WP-02F2-96-11	WP-03F2-38-11 WP-03F2-152-11 WP-03F2-163-11	WP-03F2-19 WP-03F2-164-11	WP-04F2-275-11 WP-04F2-263-11 WP-04F2-44	WP-05F2-207-11 WP-05F2-196-11 WP-05F2-44

WP-05F2-207-11	GOLD 10u"	STAINLESS STEEL 316
WP-04F2-275-11	GOLD 10u"	STAINLESS STEEL 316
WP-03F2-164-11	GOLD 10u"	STAINLESS STEEL 316
WP-03F2-163-11	GOLD 10u"	STAINLESS STEEL 316
WP-02F2-96-11	GOLD 10u"	STAINLESS STEEL 316
WP-02F2-95-11	GOLD 10u"	STAINLESS STEEL 316
WP-05F2-196-11	GOLD FLASH	BRASS/NICKEL
WP-04F2-263-11	GOLD FLASH	BRASS/NICKEL
WP-03F2-152-11	GOLD FLASH	BRASS/NICKEL
WP-05F2-44	GOLD 10u"	BRASS/NICKEL
WP-04F2-44	GOLD 10u"	BRASS/NICKEL
WP-03F2-19	GOLD 10u"	BRASS/NICKEL
WP-03F2-38-11	GOLD 10u"	BRASS/NICKEL
WP-02F2-23-11	GOLD 10u"	BRASS/NICKEL
WP-02F2-36-11	GOLD 10u"	BRASS/NICKEL
PART NO	FINISH	NUT MATERIAL/FINISH

DRAWN	Emily Suen	APP'D	KU CHOU	UNIT	mm	TOLERANCE			广东科斯达电子科技有限公司 GUANG DONG KE SI DA ELECTRONIC TECHNOLOGY CO., LTD.	TITLE	防水頭 (F) 線端(膠芯L=22.8)			SHEET	1
CHK'D	KU CHOU			SCALE	1:1					PART NO.	SEE TABLE A	DWG NO.	QC4293	VERSION	B