

CUSTOMER DRAWING

REV.	DESCRIPTION	APPVL. BY	DATE	ECN NO.
A	RELEASE	Fido Weng	06/05/13*	
B				
C				

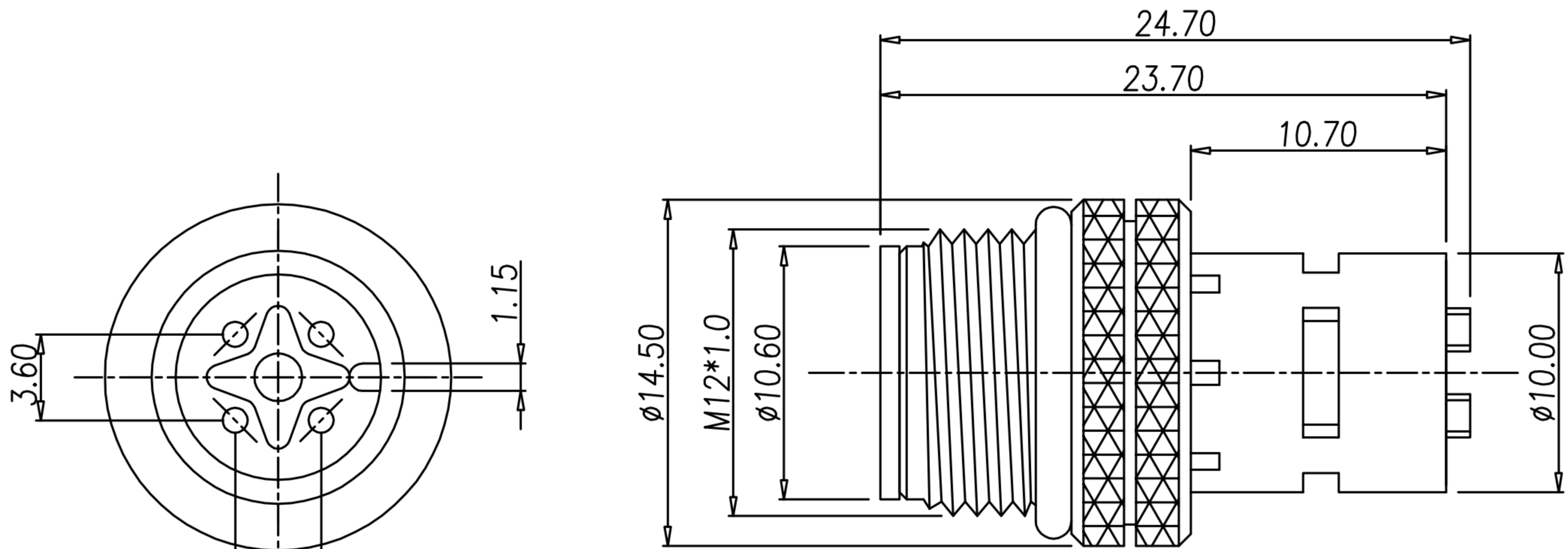

- MATERIAL :
 - HOUSING : SEE TABLE A UL94V-0 ; COLOR : BLACK
 - CONTACT : BRASS
 - NUT : SEE TABLE A
 - O-RING : EPDM ; COLOR : BLACK
 - SHELL : SEE TABLE A
- FINISH :
 - CONTACT : SEE TABLE A
UNDER PLATE : NICKEL
 - NUT : SEE TABLE A
 - SHELL : SEE TABLE A
- ELECTRICAL SPECIFICATION :
 - Rated current : 4A
 - Rated Voltage : 2PIN~4PIN 250V ; 5PIN 60V
 - Water proof : IP68
- Environmental :
 - Operation Temperature : -20°C~85°C

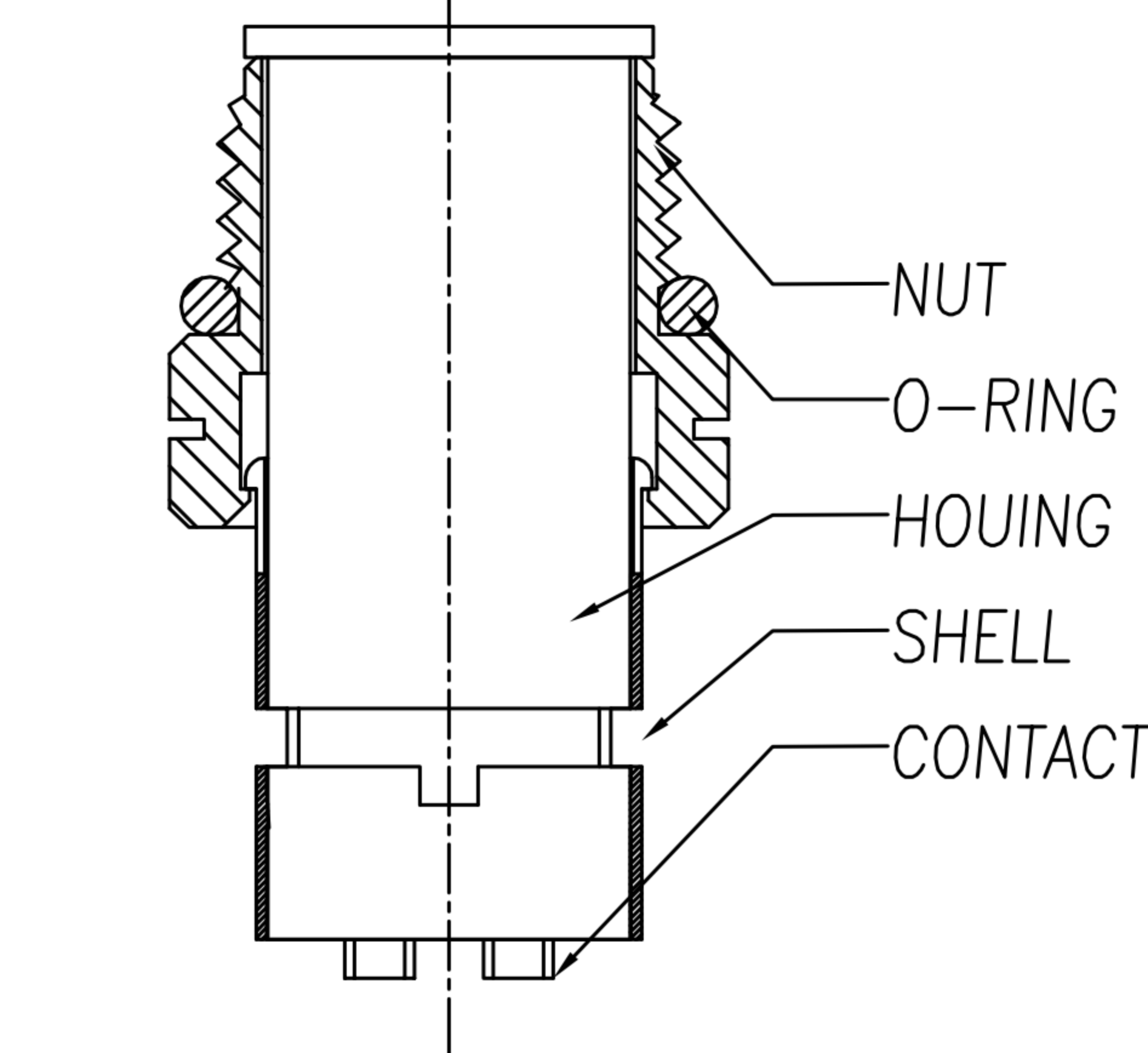
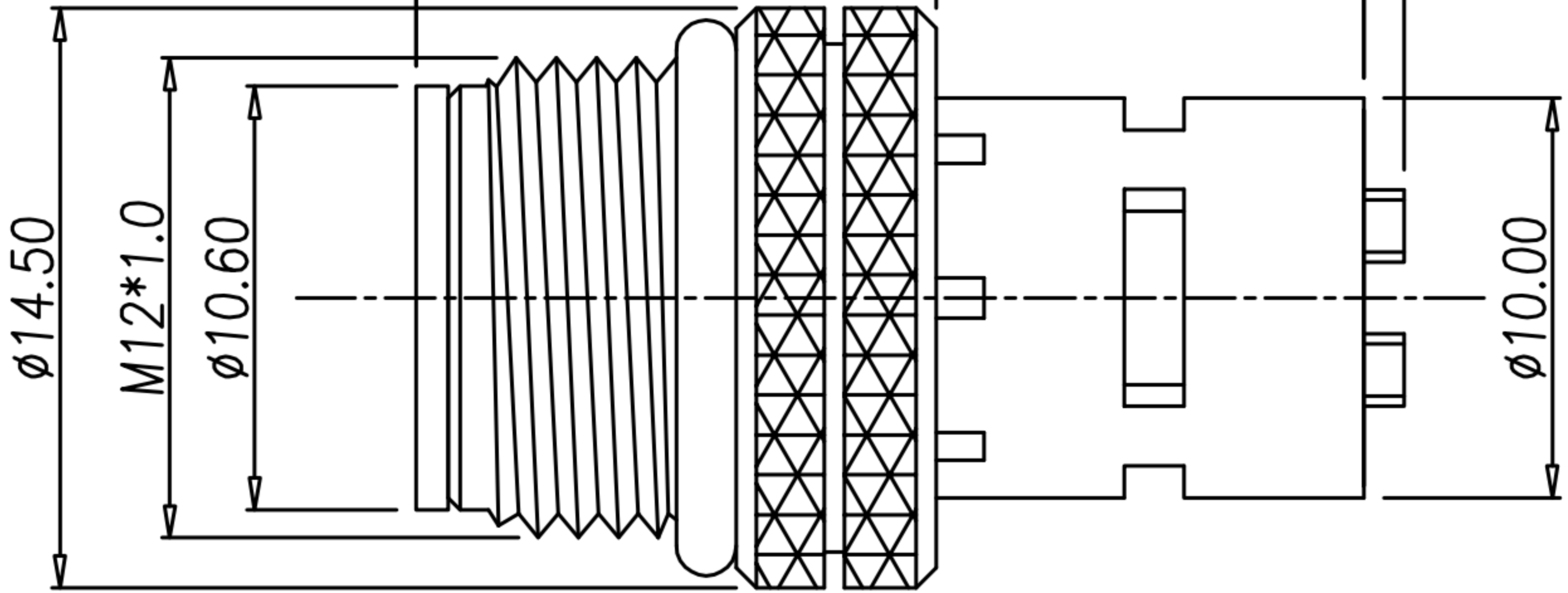
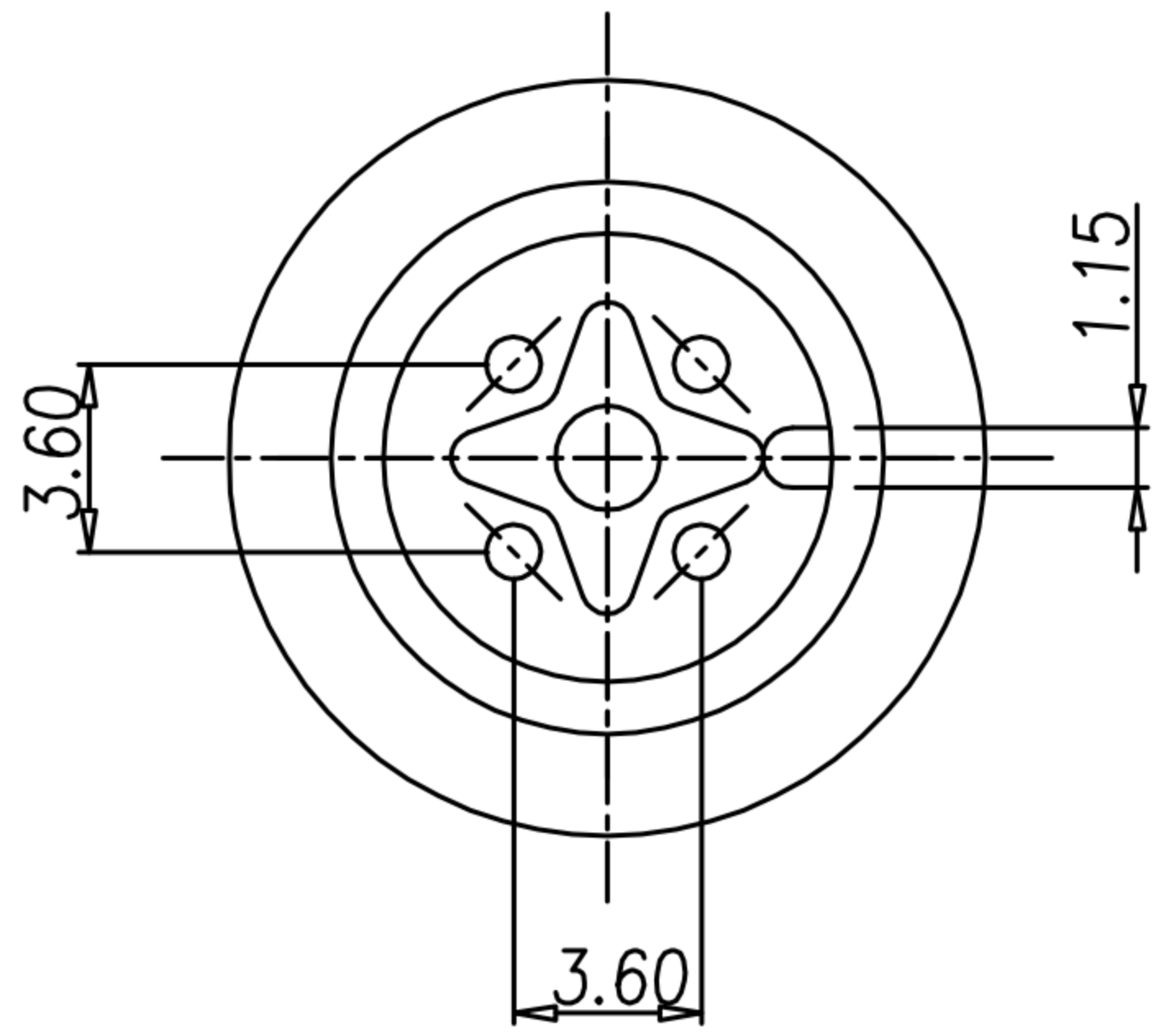

TABLE A

2PIN	3PIN	3PIN	4PIN	5PIN		
 WP-02M2-89-11	 WP-03M2-74-11 WP-03M2-75-11	 WP-03M2-76-11 WP-03M2-77-11	 WP-04M2-82-11 WP-04M2-126-11 WP-04M2-217-11 WP-04M2-218-11	 WP-05M2-99-11 WP-05M2-107-11 WP-05M2-112-11 WP-05M2-175-11 WP-05M2-176-11		
WP-04M2-218-11	GOLD 10u"	PBT	STAINLESS STEEL 316	PASSIVATION	STAINLESS STEEL 316	PASSIVATION
WP-04M2-217-11	GOLD 10u"	PBT	BRASS	BRIGHT TIN PLATED	STAINLESS STEEL 316	PASSIVATION
WP-05M2-176-11	GOLD 10u"	PBT	STAINLESS STEEL 316	PASSIVATION	STAINLESS STEEL 316	PASSIVATION
WP-05M2-175-11	GOLD 10u"	PBT	BRASS	BRIGHT TIN PLATED	STAINLESS STEEL 316	PASSIVATION
WP-02M2-89-11	GOLD FLASH	PBT	BRASS	BRIGHT TIN PLATED	BRASS	NICKEL PLATED
WP-03M2-74-11	GOLD FLASH	PBT	BRASS	BRIGHT TIN PLATED	BRASS	NICKEL PLATED
WP-03M2-75-11	GOLD 10u"	PBT	BRASS	BRIGHT TIN PLATED	BRASS	NICKEL PLATED
WP-03M2-76-11	GOLD FLASH	PBT	BRASS	BRIGHT TIN PLATED	BRASS	NICKEL PLATED
WP-03M2-77-11	GOLD 10u"	PBT	BRASS	BRIGHT TIN PLATED	BRASS	NICKEL PLATED
WP-04M2-126-11	GOLD FLASH	PBT	BRASS	BRIGHT TIN PLATED	BRASS	NICKEL PLATED
WP-04M2-82-11	GOLD 10u"	PBT	BRASS	BRIGHT TIN PLATED	BRASS	NICKEL PLATED
WP-05M2-107-11	GOLD FLASH	PBT	BRASS	BRIGHT TIN PLATED	BRASS	NICKEL PLATED
WP-05M2-99-11	GOLD 10u"	PBT	BRASS	BRIGHT TIN PLATED	BRASS	NICKEL PLATED
WP-05M2-112-11	GOLD 10u"	NYLON 66	BRASS	BRIGHT TIN PLATED	BRASS	NICKEL PLATED
PART NO	FINISH(CONTACT)	MATERIAL(HOUSING)	MATERIAL(SHELL)	FINISH(SHELL)	MATERIAL(NUT)	FINISH(NUT)

DRAWN	Mark Kao	APP'D	Ku Chou	UNIT	mm	TOLERANCE			广东科斯达电子科技有限公司 GUANG DONG KE SI DA ELECTRONIC TECHNOLOGY CO., LTD.	TITLE	防水頭 M12 (M)A-CODE 接地線式			SHEET	1
CHK'D	Emily Suen			SCALE	1:1					PART NO.	SEE TABLE A	DWG NO.	QC6180	VERSION	