

# CUSTOMER DRAWING

REV.	DESCRIPTION	APPROVED BY	DATE	ECN NO.
△A	RELEASE	Fido Weng	22/11/11'	
△B	ADD TABLE A	Fido Weng	06/11/13'	
△C				

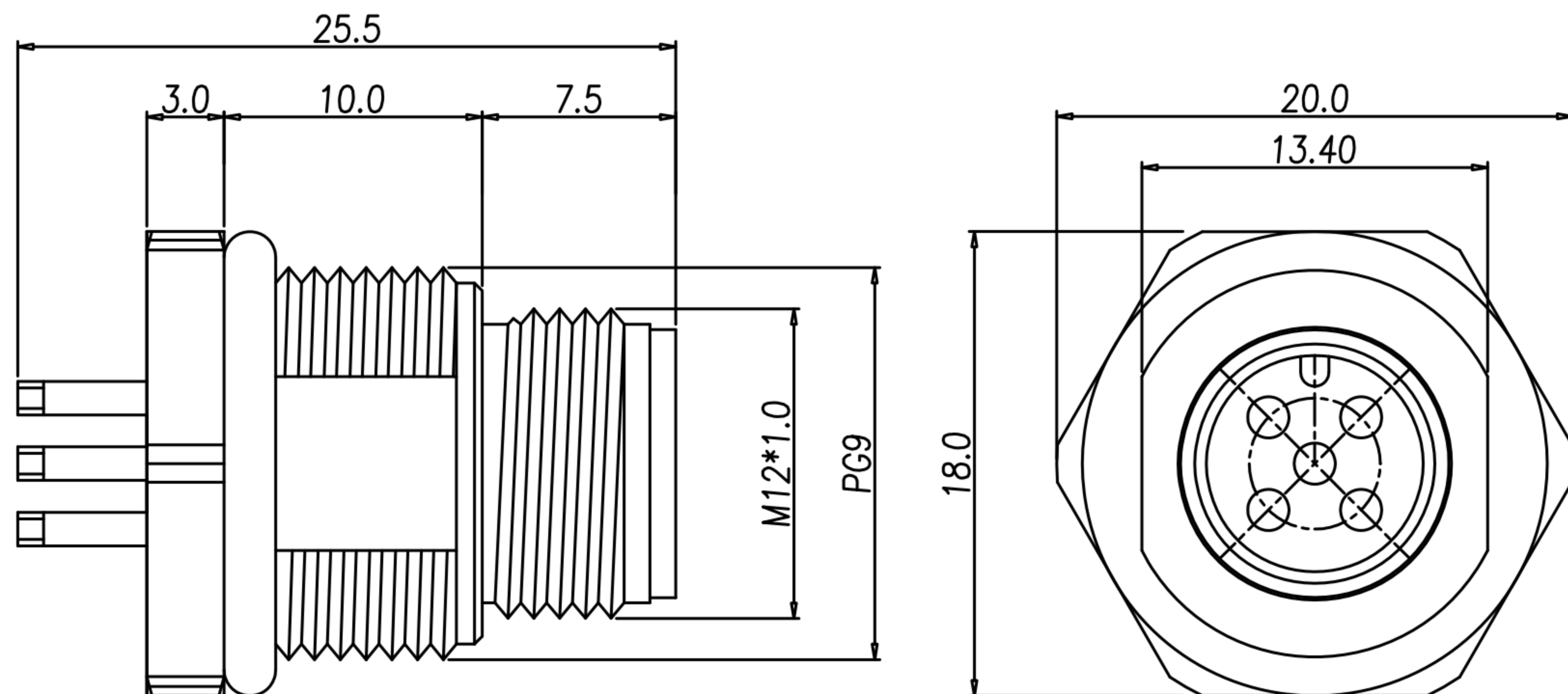

△B TABLE A

4PIN	5PIN
WP-04M2-89-11	WP-05M2-64
2PIN	3PIN
WP-02M2-92-11	WP-03M2-151-11

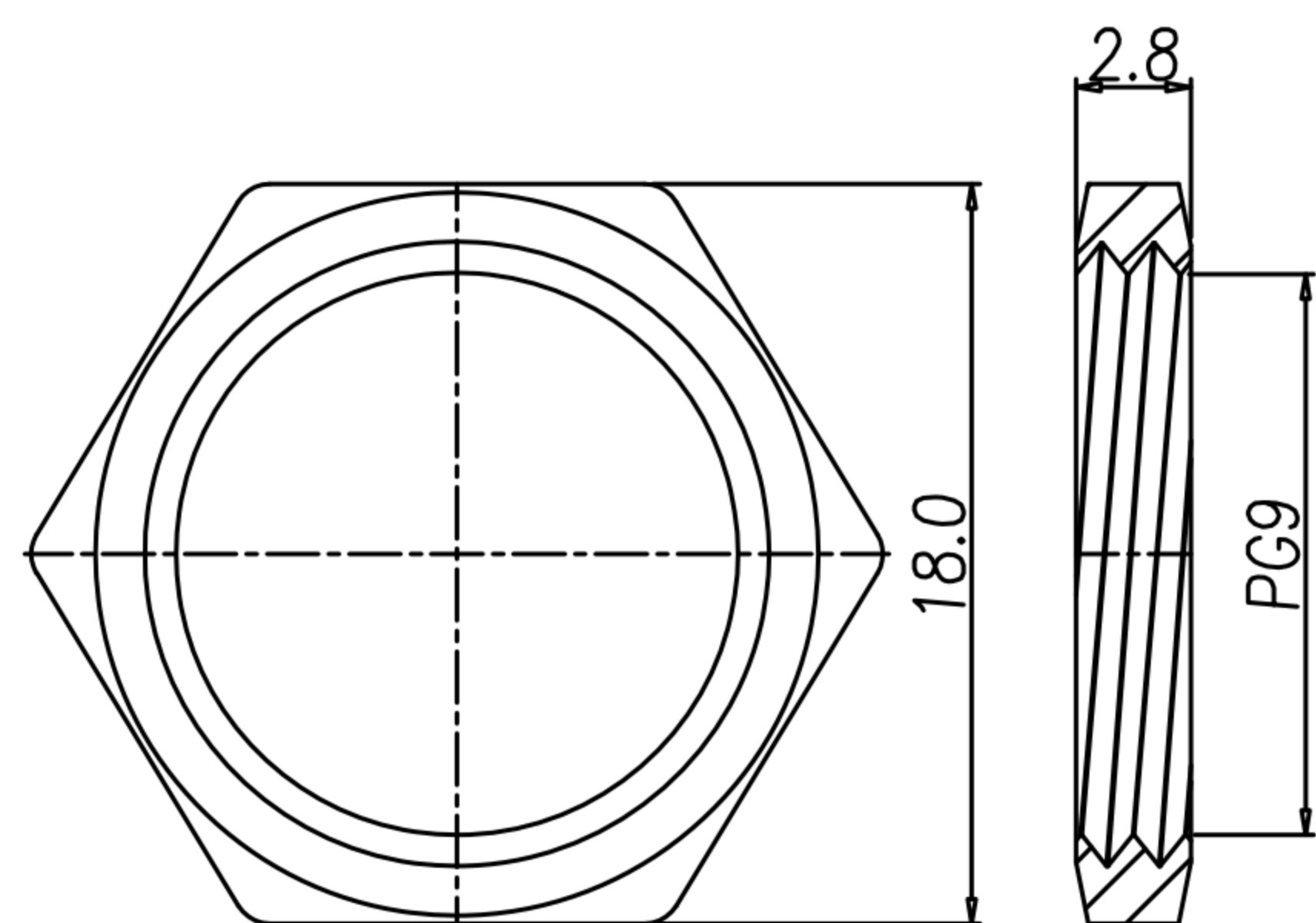

NUT

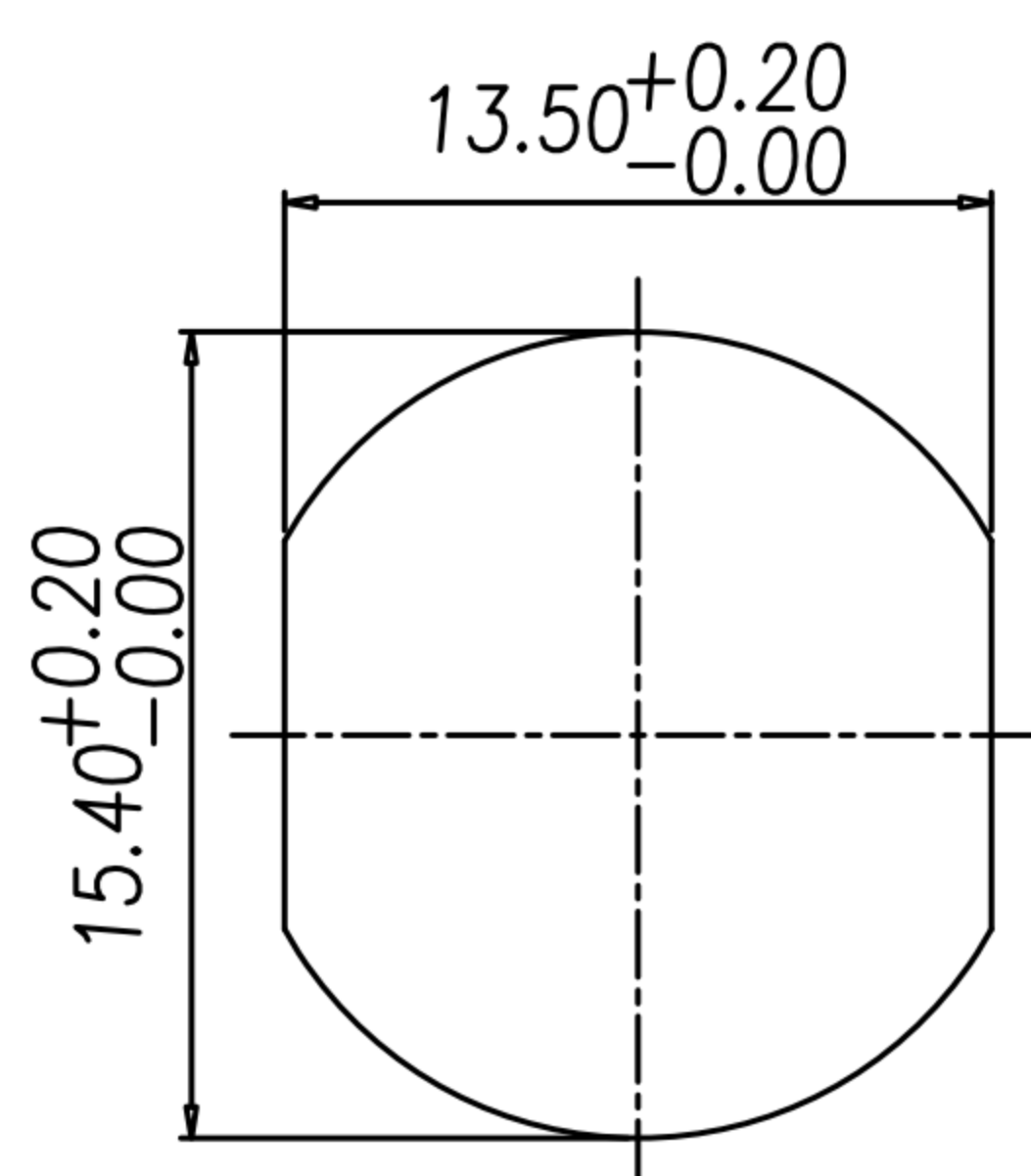

RECOMMEND PANEL CUT-OUT

- MATERIAL :
  - 1-1. HOUSING : PBT UL94V-0 ; COLOR : BLACK
  - 1-2. CONTACT : BRASS
  - 1-3. NUT : BRASS
  - 1-4. SHELL : BRASS
  - 1-5. O-RING : EPDM
- FINISH :
  - 2-1. CONTACT : 10 MICRO INCHES MIN. GOLD PLATED  
UNDER PLATE : NICKEL
  - 2-2. NUT : NICKEL PLATED
  - 2-3. SHELL : NICKEL PLATED
- ELECTRICAL SPECIFICATION :
  - 3-1. Rated current : 4A
  - 3-2. Rated Voltage : 2~4PIN 250V ; 5PIN 60V
  - 3-3. Water proof : IP67
- Environmental :
  - 4-1. Operation Temperature : -40℃~85℃

DRAWN	Ku Chou	APPEND	Fido Weng	UNIT	mm	TOLERANCE		广东科斯达电子科技有限公司 GUANG DONG KE SI DA ELECTRONIC TECHNOLOGY CO., LTD.	TITLE	M12 PIN A-code (M) 前鎖PG9 彈簧式(洗雙邊/無溝槽)			SHEET	1/1
CHKD	Emily Suen			SCALE	1:1				PART NO.	SEE TABLE A	DWG NO.	QC5734	VERSION	