

# CUSTOMER DRAWING

REV.	DESCRIPTION	APPROVED BY	DATE	ECN NO.
A	RELEASE	Fido Weng	04/03/10'	
B				
C				

TABLE A

5PIN	4PIN	3PIN	3PIN	2PIN
WP-05F2-62 WP-05F2-112-11 WP-05F3-18-11	WP-04F2-78 WP-04F2-154-11 WP-04F3-14-11	WP-03F2-27 WP-03F2-77-11	WP-03F2-59-11 WP-03F2-78-11	WP-02F2-17
WP-05F3-18-11	STAINLESS STEEL 316	-	-	GOLD 10u"
WP-04F3-14-11	STAINLESS STEEL 316	-	-	GOLD 10u"
WP-05F2-112-11	BRASS	NICKEL PLATED		GOLD FLASH
WP-04F2-154-11	BRASS	NICKEL PLATED		GOLD FLASH
WP-03F2-78-11	BRASS	NICKEL PLATED		GOLD FLASH
WP-03F2-77-11	BRASS	NICKEL PLATED		GOLD FLASH
WP-05F2-62	BRASS	NICKEL PLATED		GOLD 10u"
WP-04F2-78	BRASS	NICKEL PLATED		GOLD 10u"
WP-03F2-59-11	BRASS	NICKEL PLATED		GOLD 10u"
WP-03F2-27	BRASS	NICKEL PLATED		GOLD 10u"
WP-02F2-17	BRASS	NICKEL PLATED		GOLD 10u"
PART NO	MATERIAL(SHELL&NUT)	FINISH(SHELL&NUT)		FINISH(CONTACT)

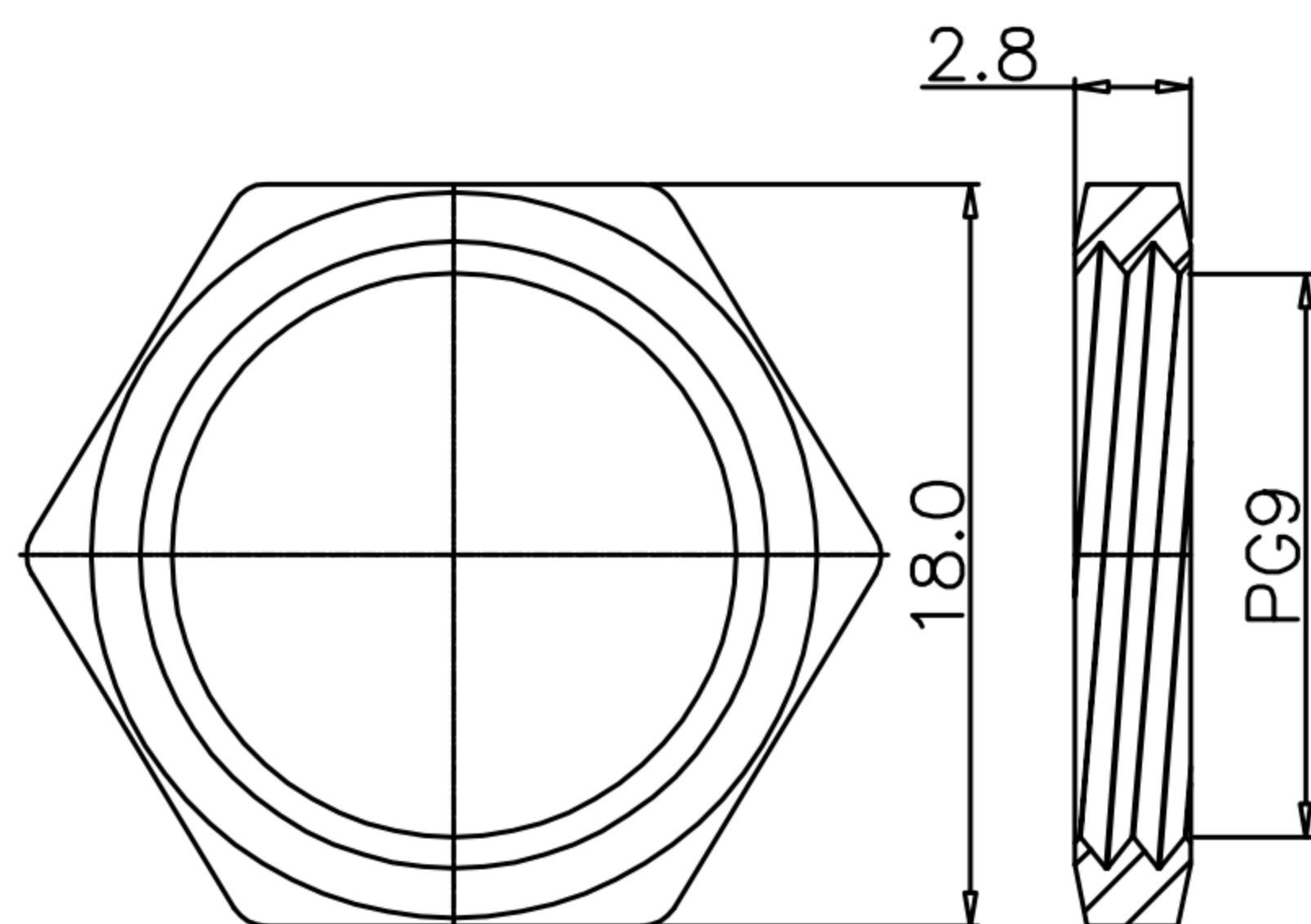
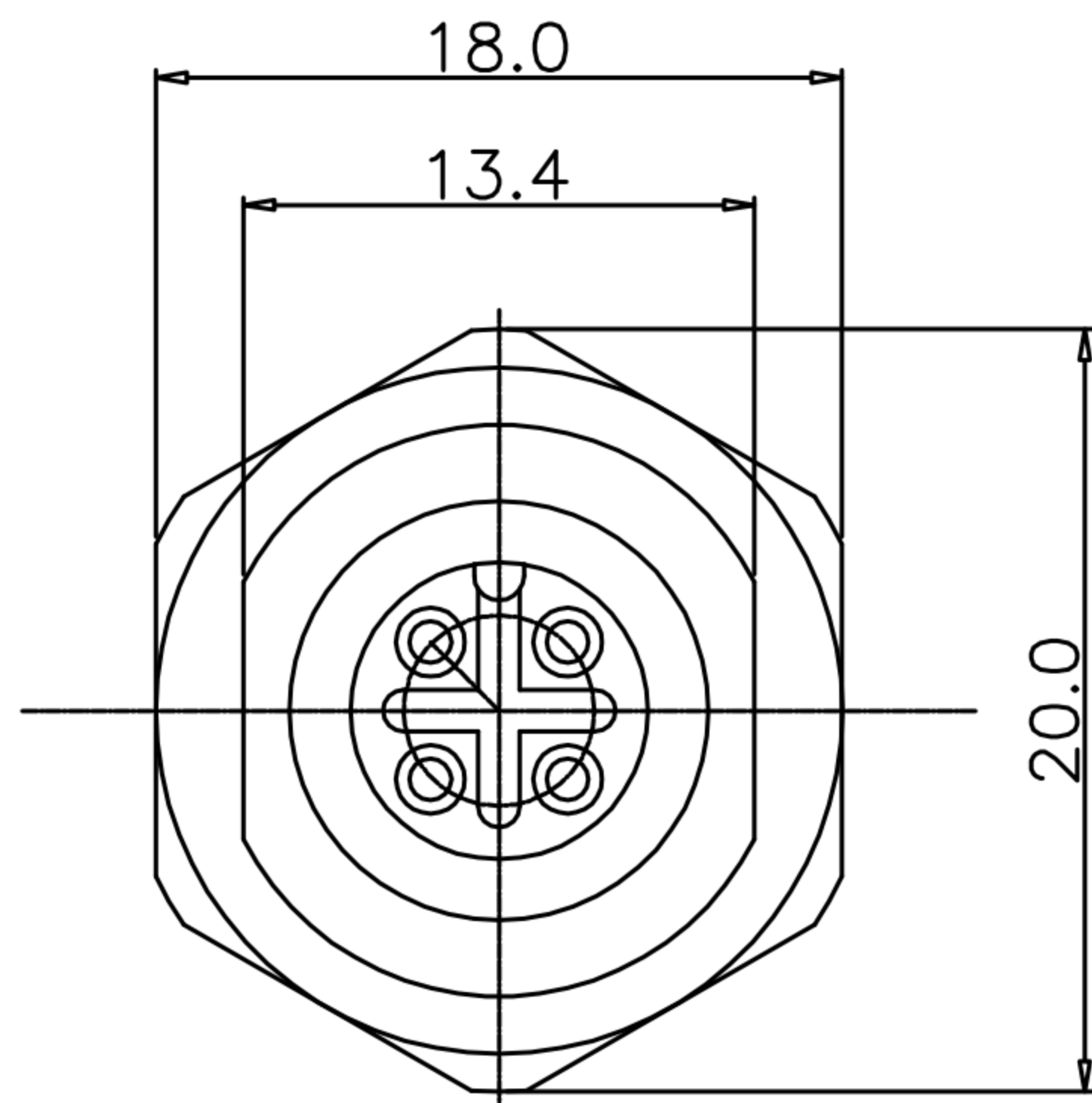
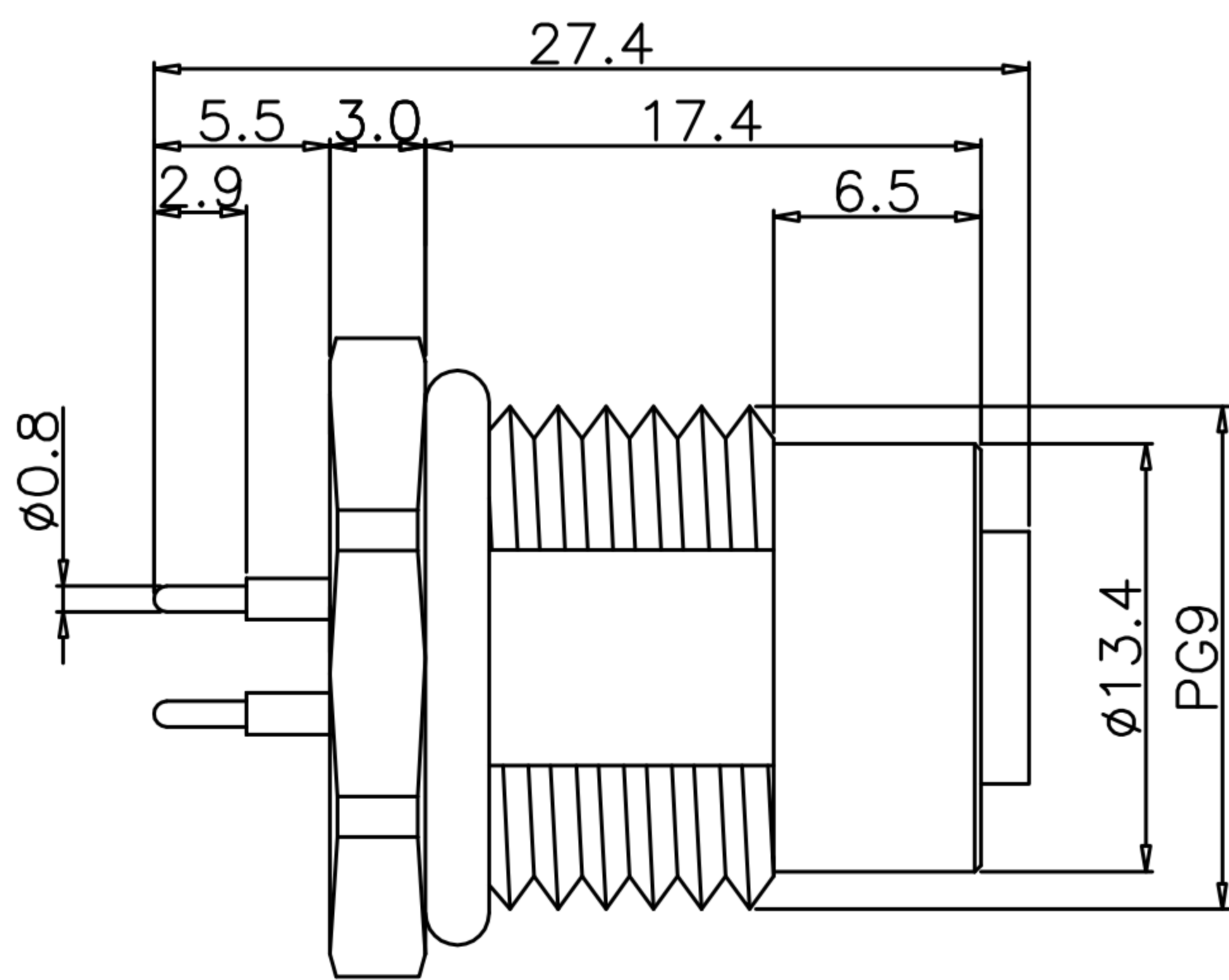

**NUT**

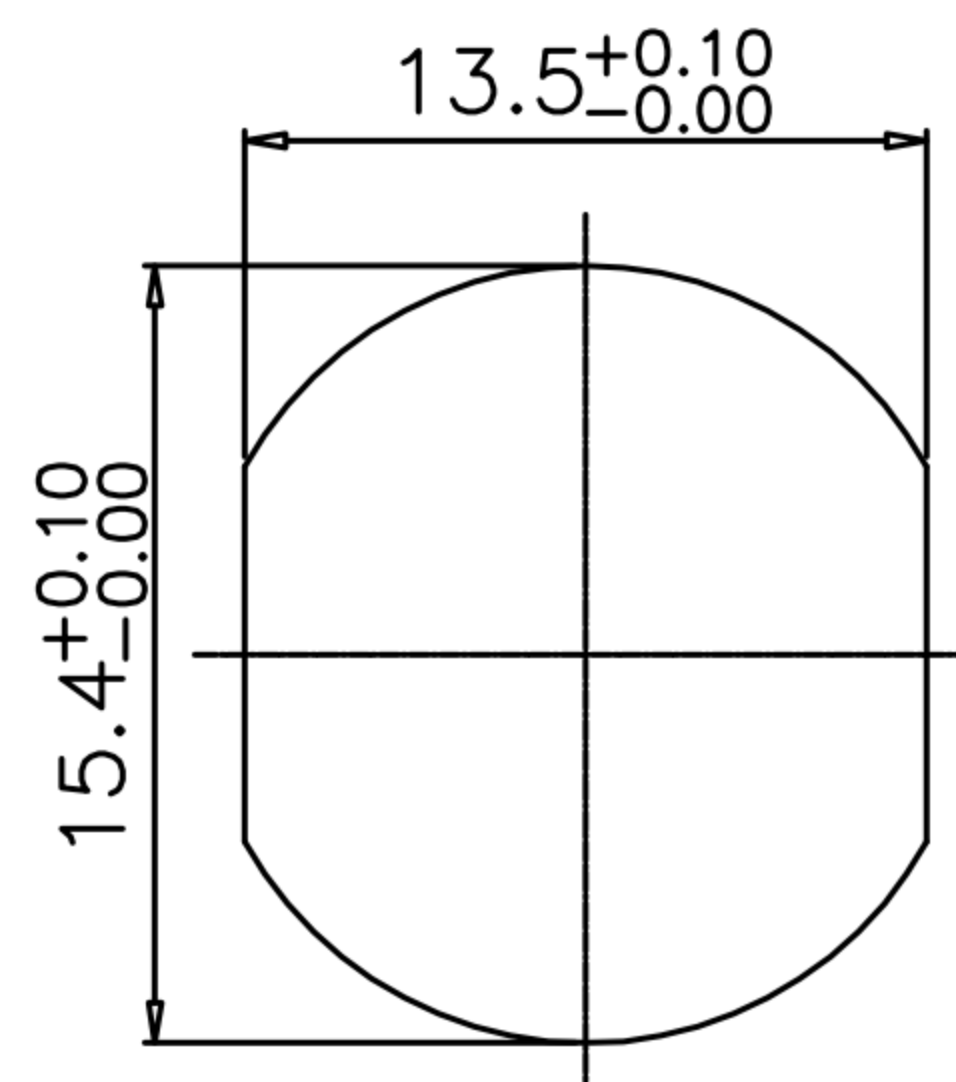

RECOMMEND PANEL CUT-OUT RECOMMEND P.C.B LAYOUT

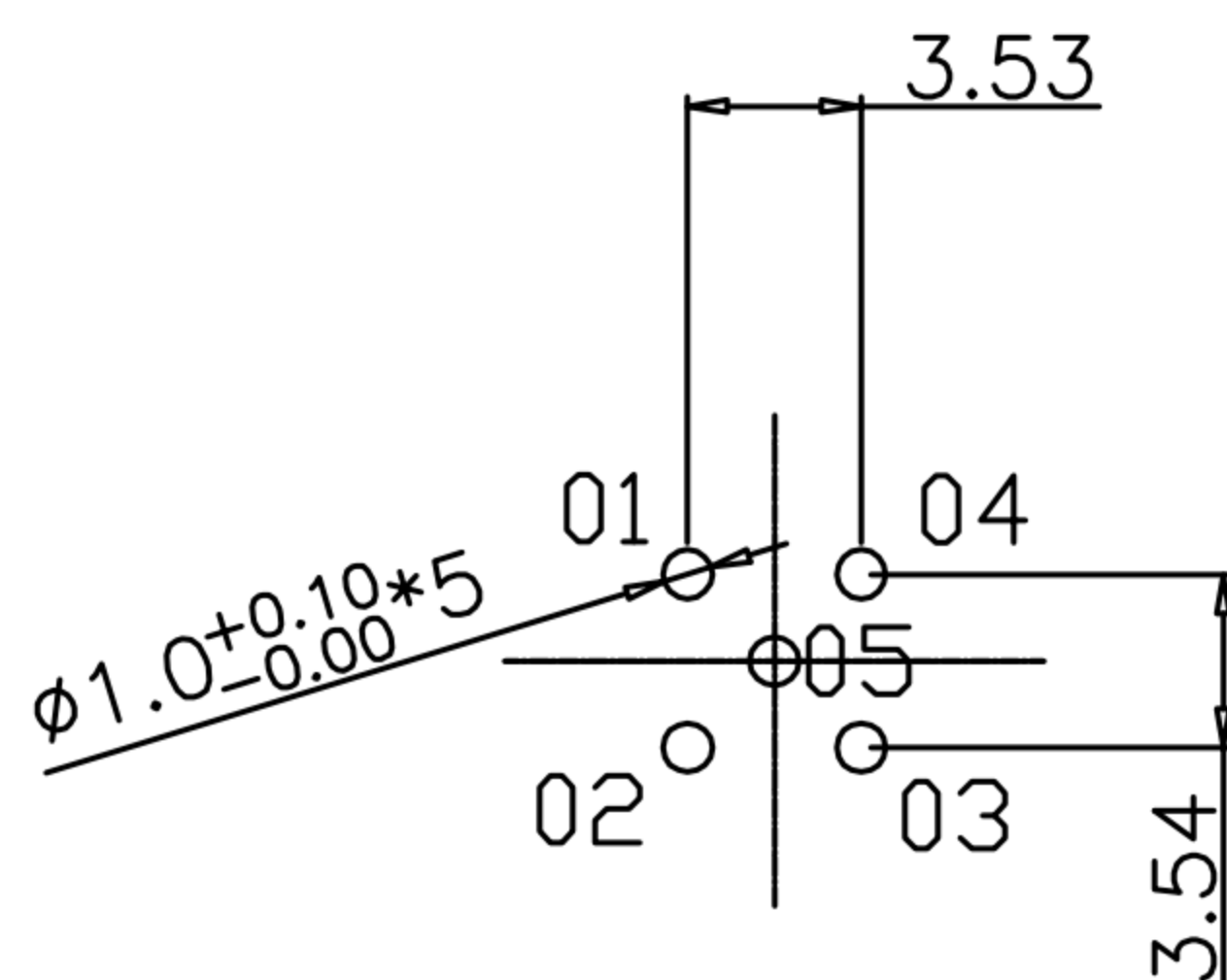

- MATERIAL :
  - HOUSING : PBT UL94V-0 ; COLOR : BLACK
  - CONTACT : BRASS
  - NUT : SEE TABLE A
  - SHELL : SEE TABLE A
  - O-RING : EPDM ; COLOR : BLACK
- FINISH :
  - CONTACT : SEE TABLE A  
UNDER PLATE : NICKEL
  - NUT : SEE TABLE A
  - SHELL : SEE TABLE A
- ELECTRICAL SPECIFICATION :
  - Rated current : 4A
  - Rated Voltage : 2~4PIN 250V ; 5PIN 60V
  - Water proof : IP67/IP68
- Environmental :
  - Operation Temperature : -40℃~85℃

DRAWN	Ku Chou	APPEND	Fido Weng	UNIT	mm	TOLERANCE			TITLE	防水头 M12 A-Code (F) 前锁 Pg9 插件式			SHEET	1/1
CHKD	Emily Suen			SCALE	1:1				PART NO.	SEE TABLE A	DWG NO.	QC5572	VERSION	A