

CUSTOMER DRAWING

REV.	DESCRIPTION	APPROVED BY	DATE	ECN NO.
△A	RELEASE	Ku Chou	06/05/19*	
△B				
△C				

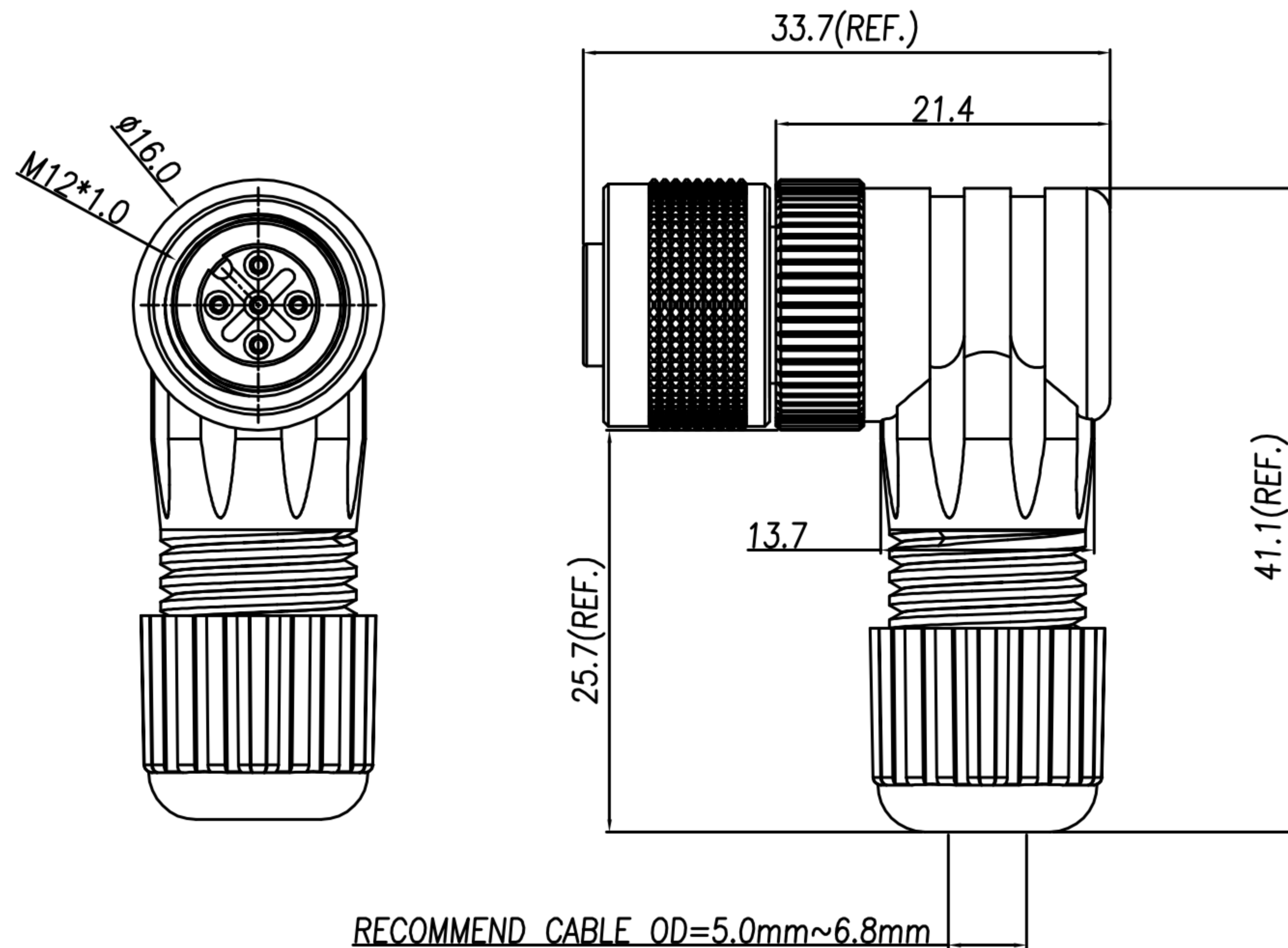

1. MATERIAL :
 - 1-1. HOUSING : PA66 ; COLOR : BLACK.
 - 1-2. CONTACT : BRASS
 - 1-3. SHELL : BRASS
 - 1-4. O-RING A : EPDM
 - 1-5. NUT : BRASS
 - 1-6. O-RING B : SILICONE
 - 1-7. CLAMP RING : PA66
 - 1-8. SEAL : SILICONE
 - 1-9. SEALING NUT : PA66
2. FINISH :
 - 2-1. CONTACT : GOLD 10U" MICRO INCHES MIN.
 - 2-2. NUT : NICKEL PLATED.
 - 2-3. SHELL : NICKEL PLATED.
3. ELECTRICAL SPECIFICATION :
 - 3-1. Rated current : 4A
 - 3-2. Rated voltage : 2~4PIN 250V ; 5PIN 60V
 - 3-3. Water proof : IP67
4. Environmental :
 - 4-1. Operation Temperature : -40℃~105℃

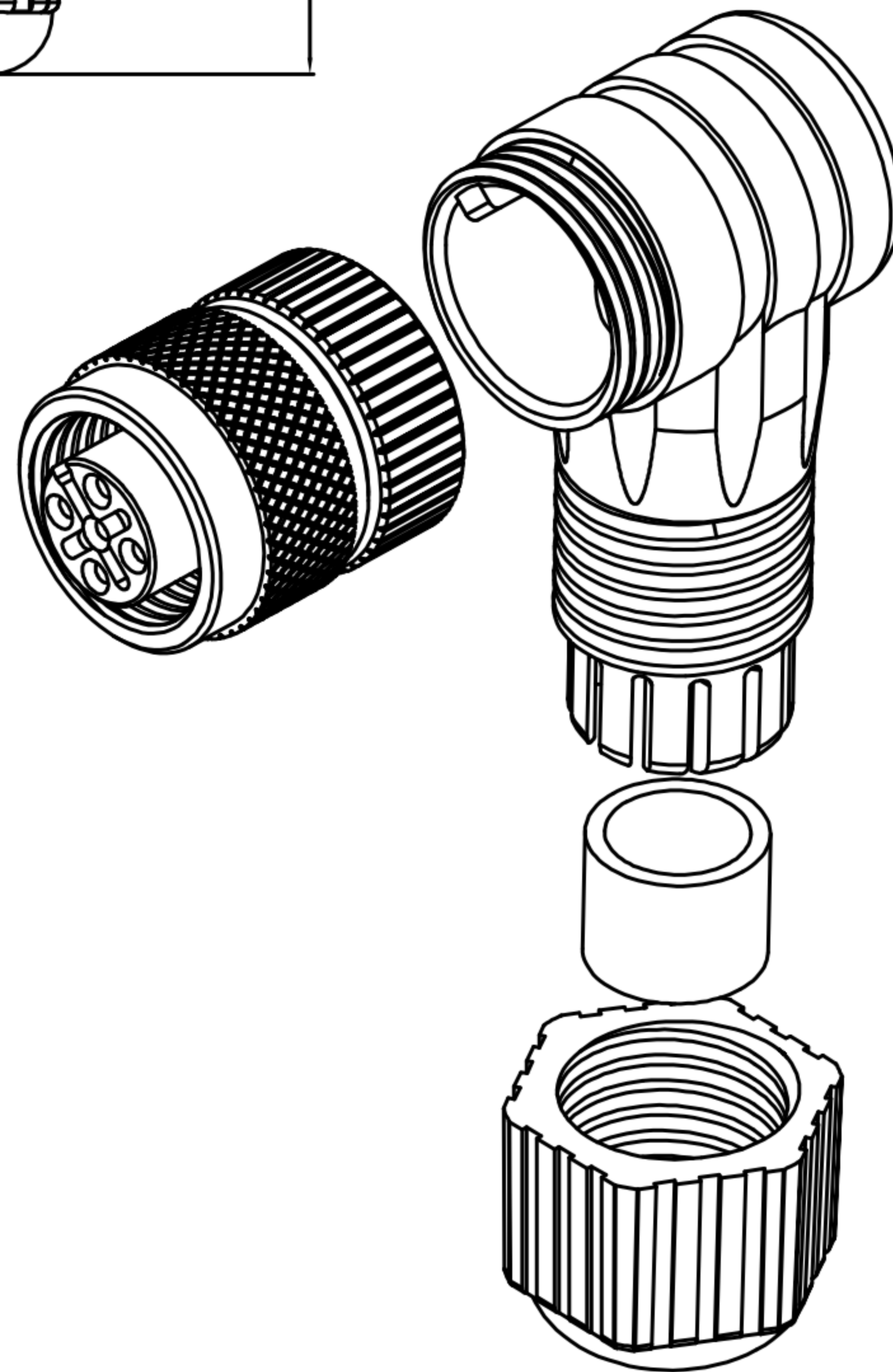

TABLE A

0° 5PIN	45°	90°	135°	180°
WP-05F2-184-11	WP-05F2-185-11	WP-05F2-186-11	WP-05F2-187-11	WP-05F2-188-11
0° 4PIN	45°	90°	135°	180°
WP-04F2-239-11	WP-04F2-240-11	WP-04F2-241-11	WP-04F2-242-11	WP-04F2-243-11
0° 3PIN	45°	90°	135°	180°
WP-03F2-127-11	WP-03F2-128-11	WP-03F2-129-11	WP-03F2-130-11	WP-03F2-131-11
0° 2PIN	45°	90°	135°	180°
WP-02F2-67-11	WP-02F2-68-11	WP-02F2-69-11	WP-02F2-70-11	WP-02F2-71-11

DRAWN	Emily Suen	APP'D	Ku Chou	UNIT	mm	TOLERANCE			广东科斯达电子科技有限公司 GUANG DONG KE SI DA ELECTRONIC TECHNOLOGY CO., LTD.	TITLE	M12 (F) A-coded 90° Assembly type(塑膠本體)防呆轉向xx°			SHEET	1
CHK'D	Ku Chou			SCALE	1:1					PART NO.	SEE TABLE A	DWG NO.	QC9377	VERSION	A