

CUSTOMER DRAWING

REV.	DESCRIPTION	APPROVED BY	DATE	ECN NO.
A	RELEASE	Fido Weng	25/02/14*	
B				
C				

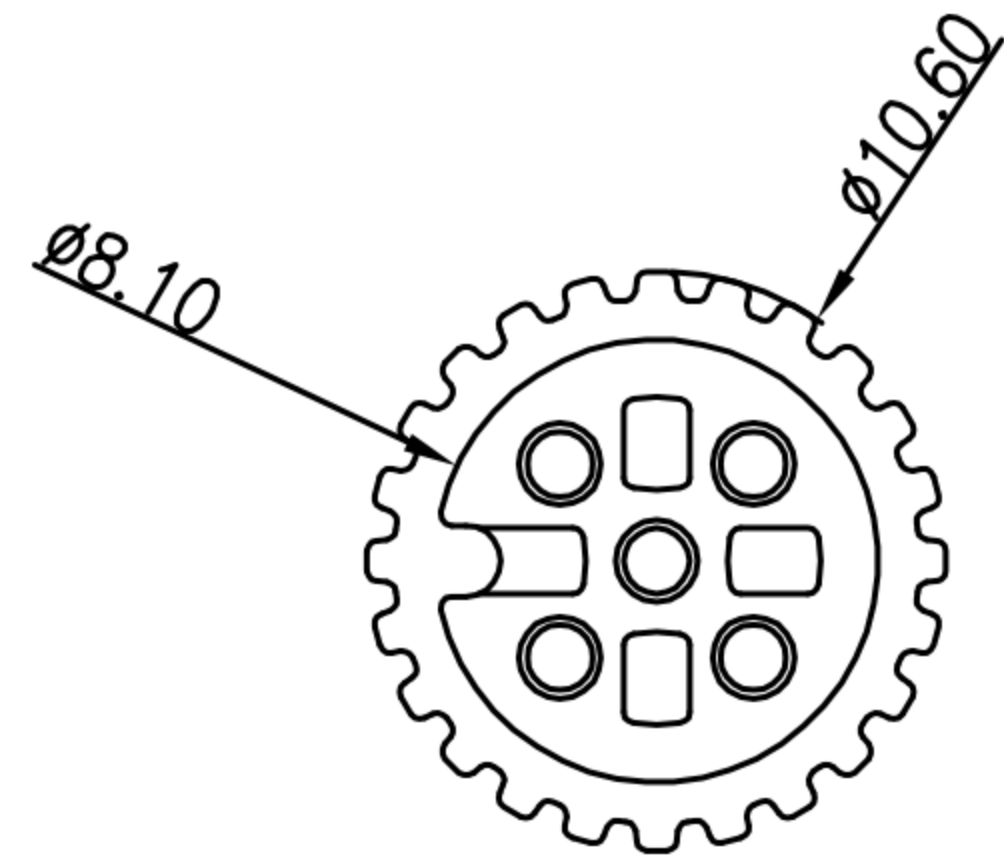

HPUSING & PIN & O-ring

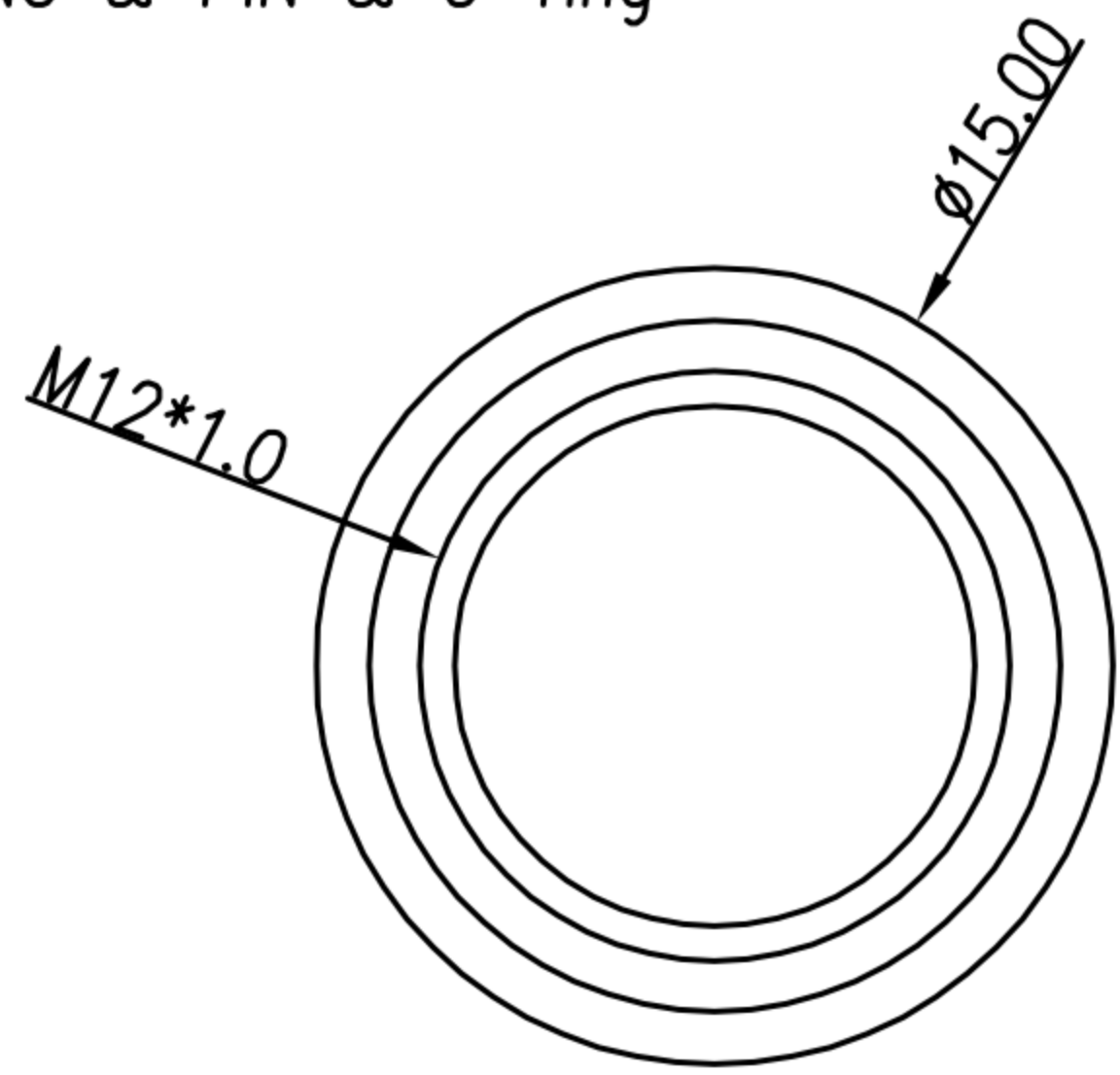
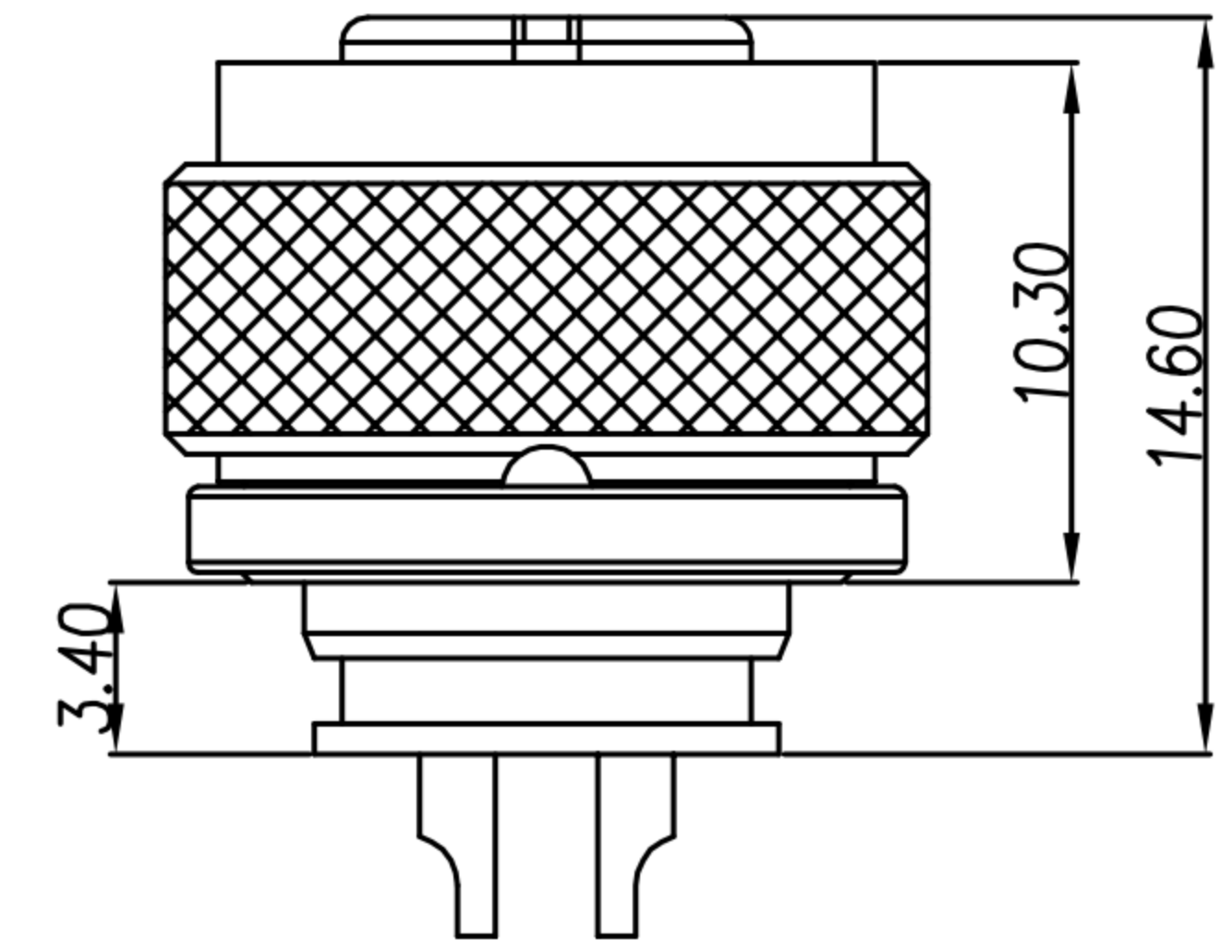
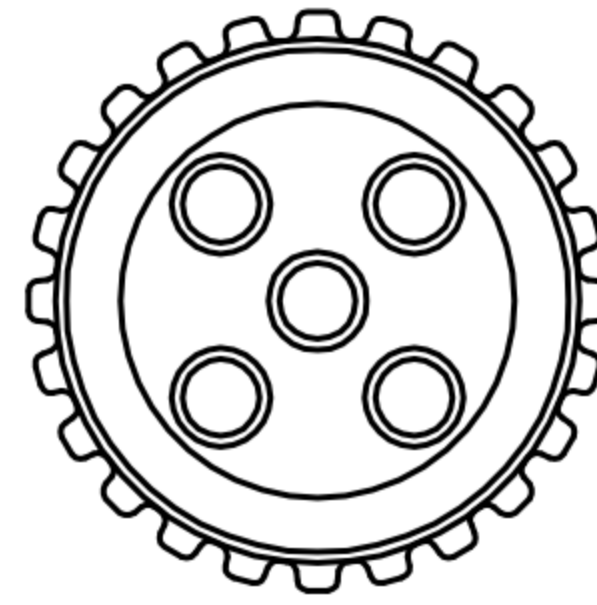
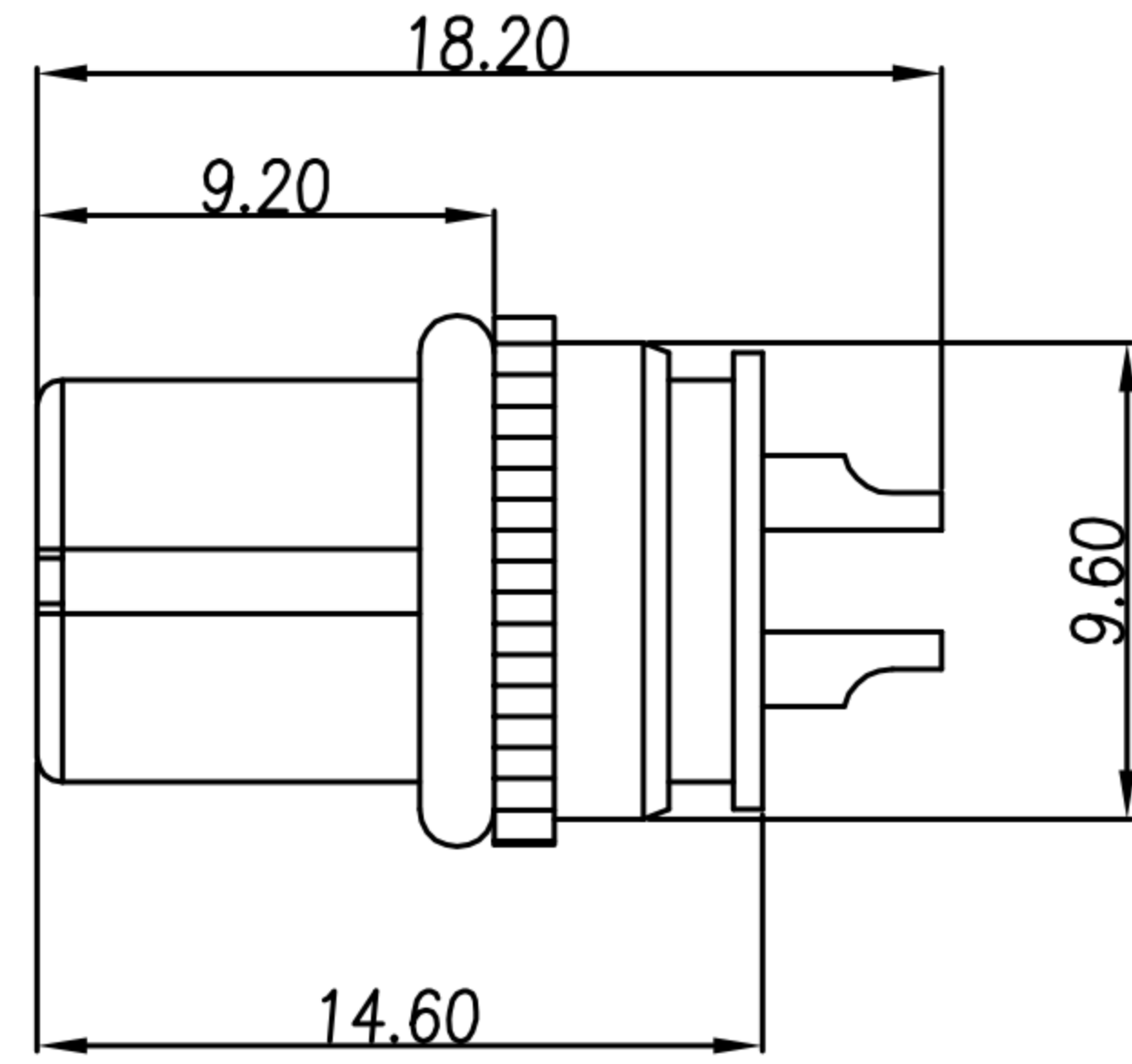

NUT & anti-vibration detent

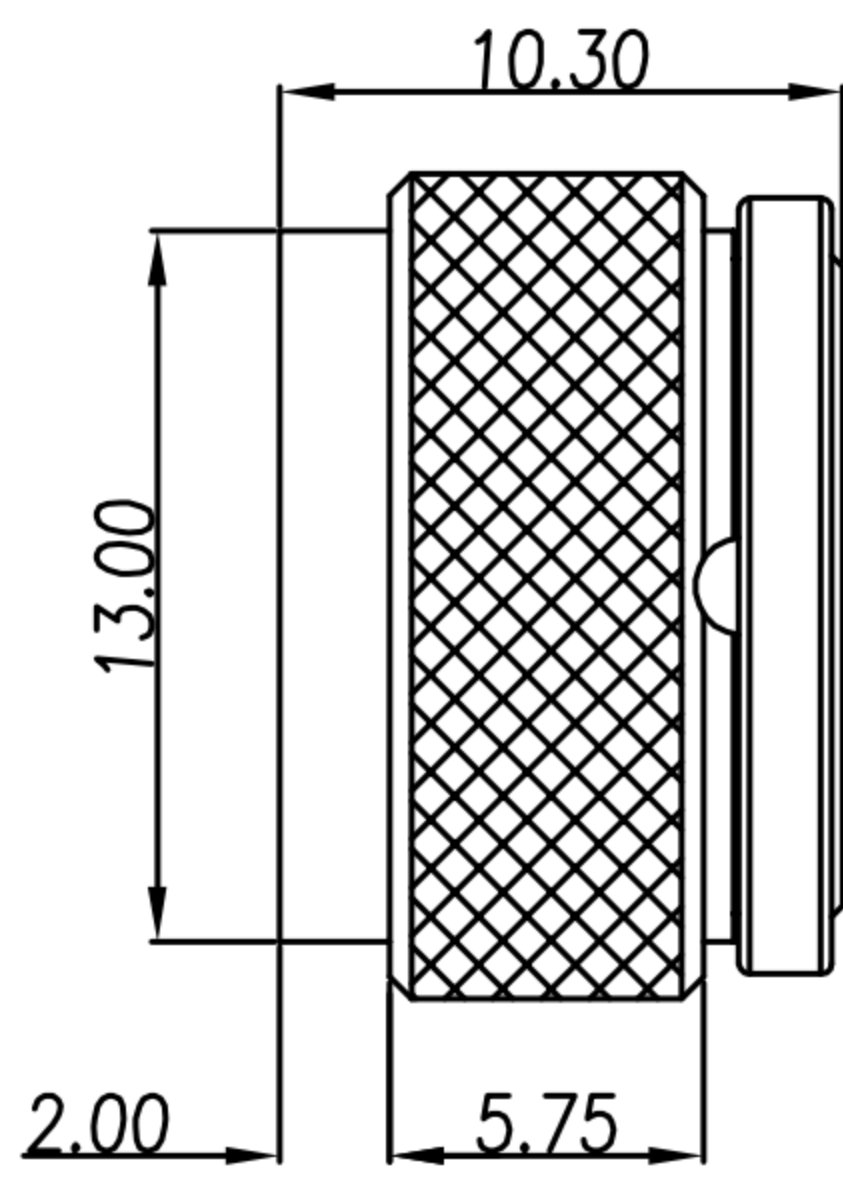

- MATERIAL :
  - 1-1. HOUSING : PA66 ; COLOR : BLACK
  - 1-2. CONTACT : BRASS
  - 1-3. NUT : SEE TABLE A
  - 1-4. O-RING : EDPM ; Color : BLACK.
- FINISH :
  - 2-1. CONTACT : SEE TABLE A  
UNDER PLATE : NICKEL
  - 2-2. NUT : SEE TABLE A
- ELECTRICAL SPECIFICATION :
  - 3-1. Rated current : 4A
  - 3-2. Rated Voltage : 3~4PIN 250V ; 5PIN 60V
  - 3-3. Water proof : IPX7
- Environmental :
  - 4-1. Operation Temperature : -20℃~85℃

WP-05F2-122-11 WP-05F2-100-11 WP-05F2-87-11	WP-04F2-168-11	WP-03F2-83-11

TABLE A/表A

WP-03F2-83-11	BRASS/NICKEL PLATED.	GOLD 10u"
WP-04F2-168-11	BRASS/NICKEL PLATED.	GOLD 10u"
WP-05F2-122-11	BRASS/NICKEL PLATED.	GOLD 10u"
WP-05F2-100-11	STAINLESS STEEL 303.	GOLD FLASH
WP-05F2-87-11	BRASS/NICKEL PLATED.	GOLD FLASH
PART NO.	NUT MATERIAL	CONTACT PLATED