

CUSTOMER DRAWING

REV.	DESCRIPTION	APPROVED BY	DATE	ECN NO.
A	RELEASE	LED	31/05/23'	
B				
C				

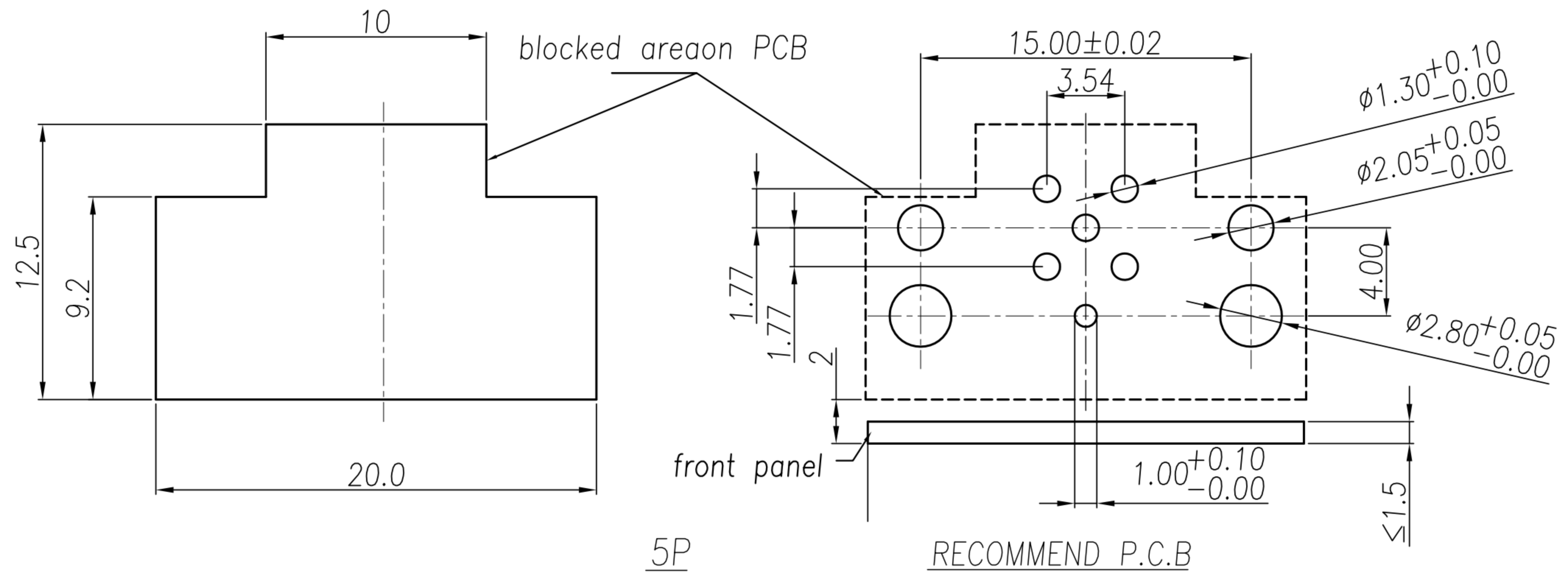
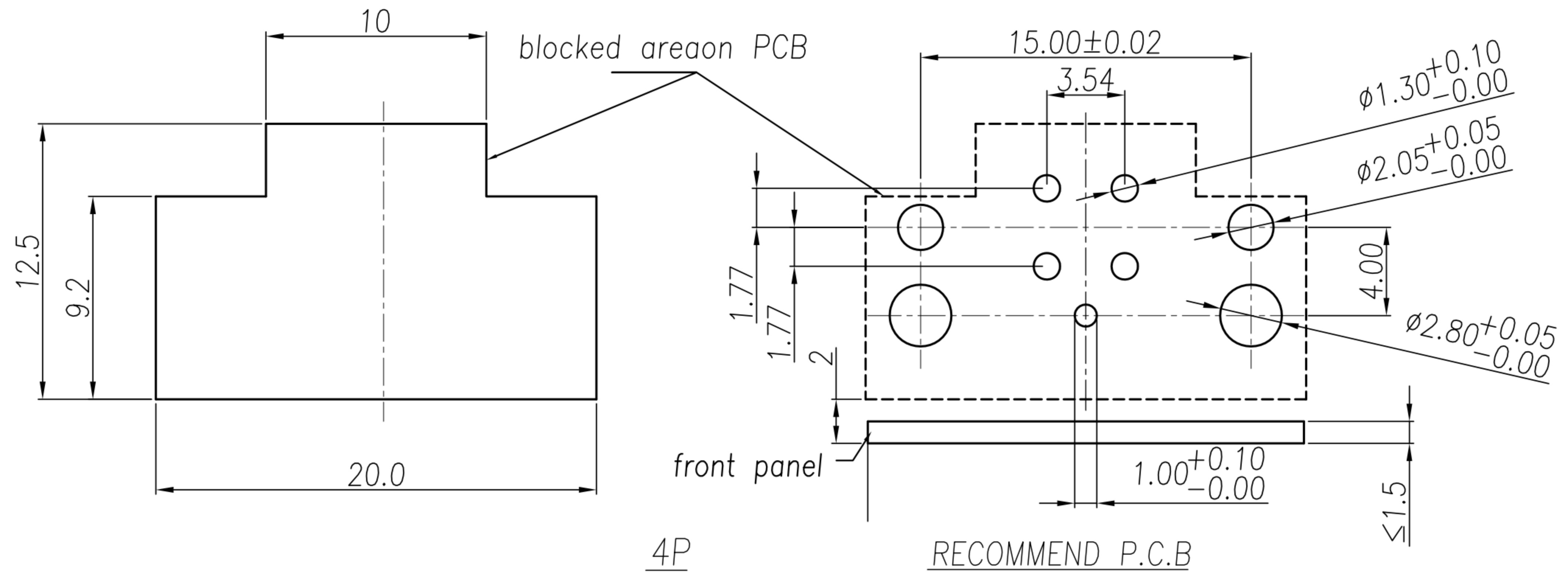

DRAWN	LED	APP'D	Ku Chou	UNIT	mm	TOLERANCE		广东科斯达电子科技有限公司 GUANG DONG KE SI DA ELECTRONIC TECHNOLOGY CO., LTD.	TITLE	WP M12 A-CODING (F) Two-piece 90度			SHEET
CHK'D	Ku Chou			SCALE	1:1	.x ±0.10 .xx ±0.05 .xxx ±0.03 .xxxx ±0.01 ANGULAR ±1°			PART NO.	TABLE A	DWG NO.	QC10812	VERSION

CUSTOMER DRAWING

REV.	DESCRIPTION	APPROVED BY	DATE	ECN NO.
A	RELEASE	LED	31/05/23'	
B				
C				

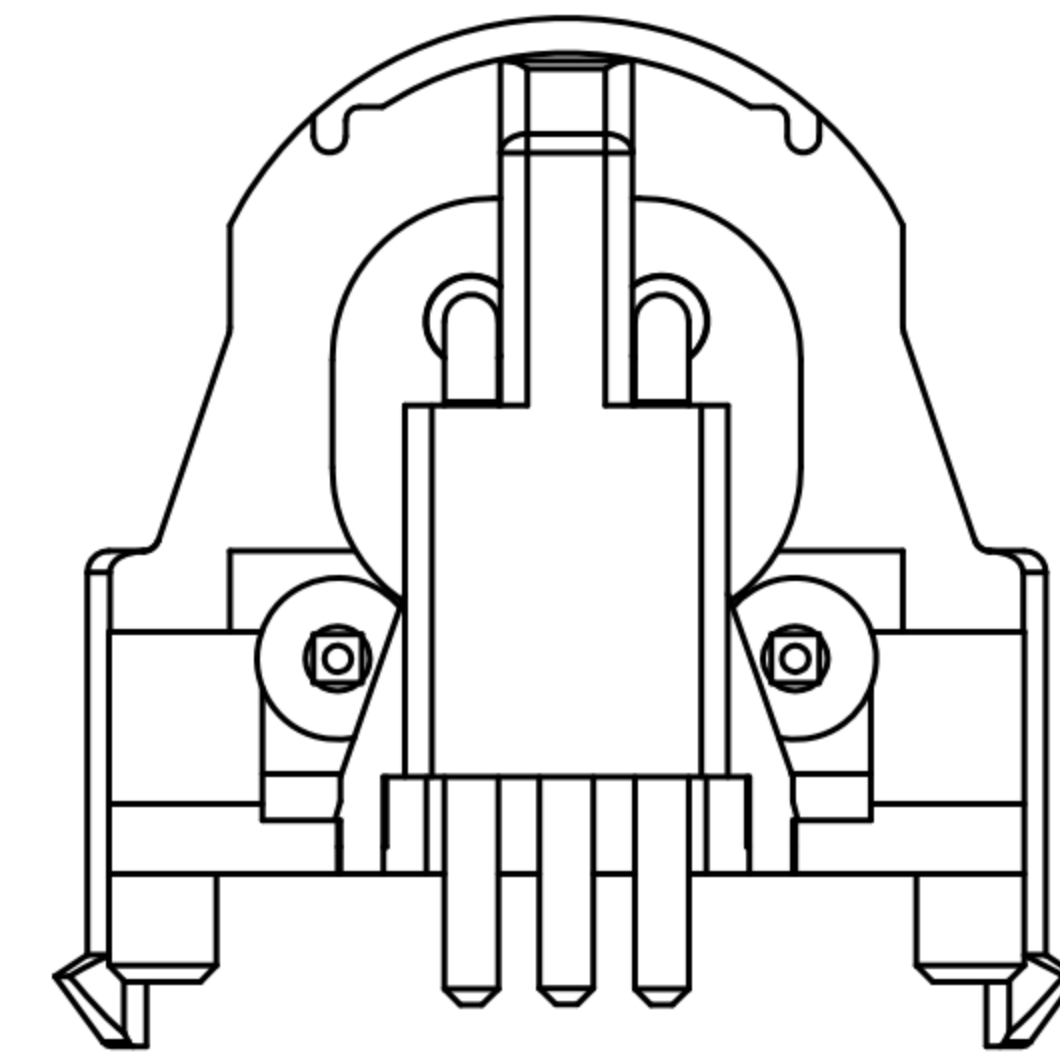
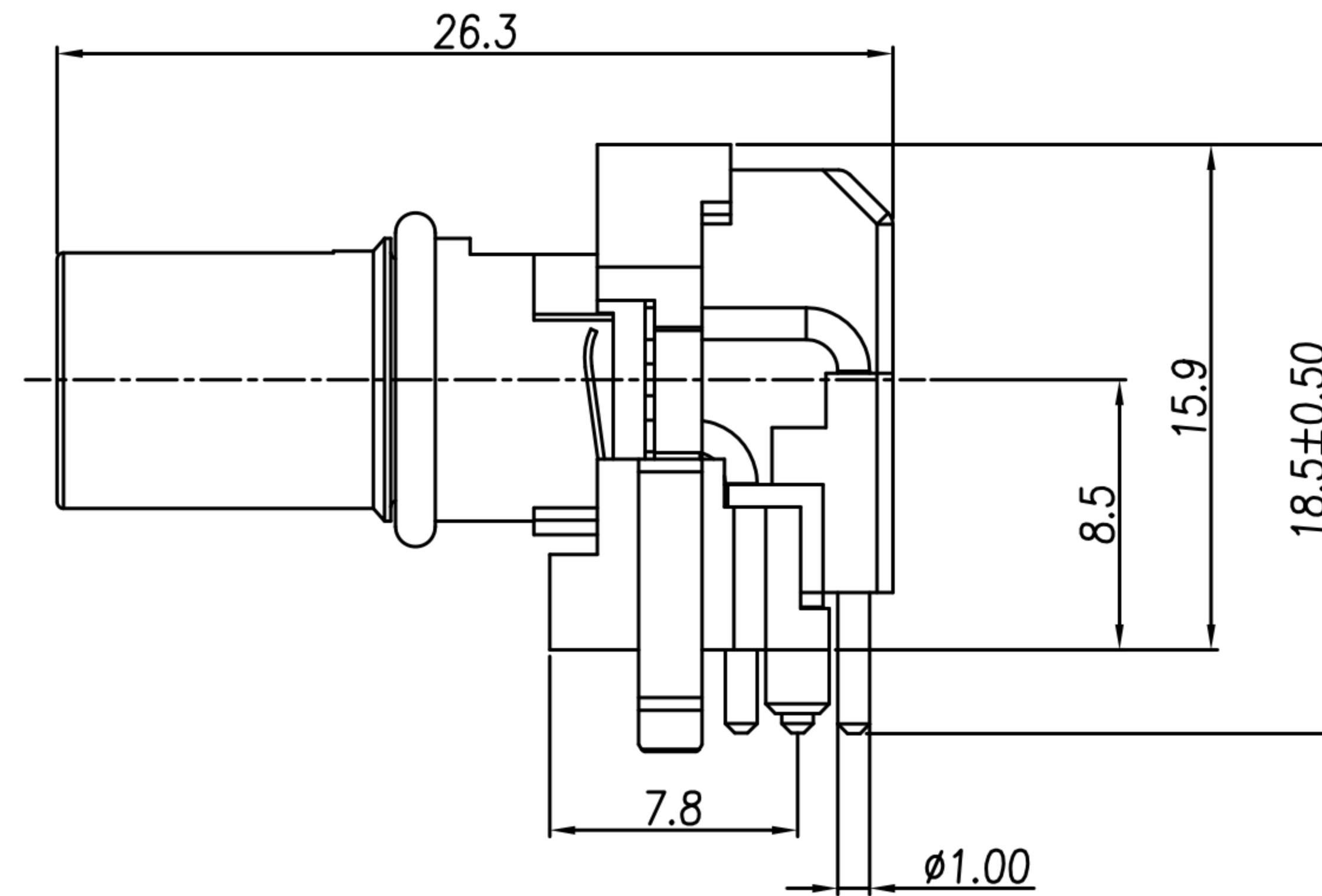
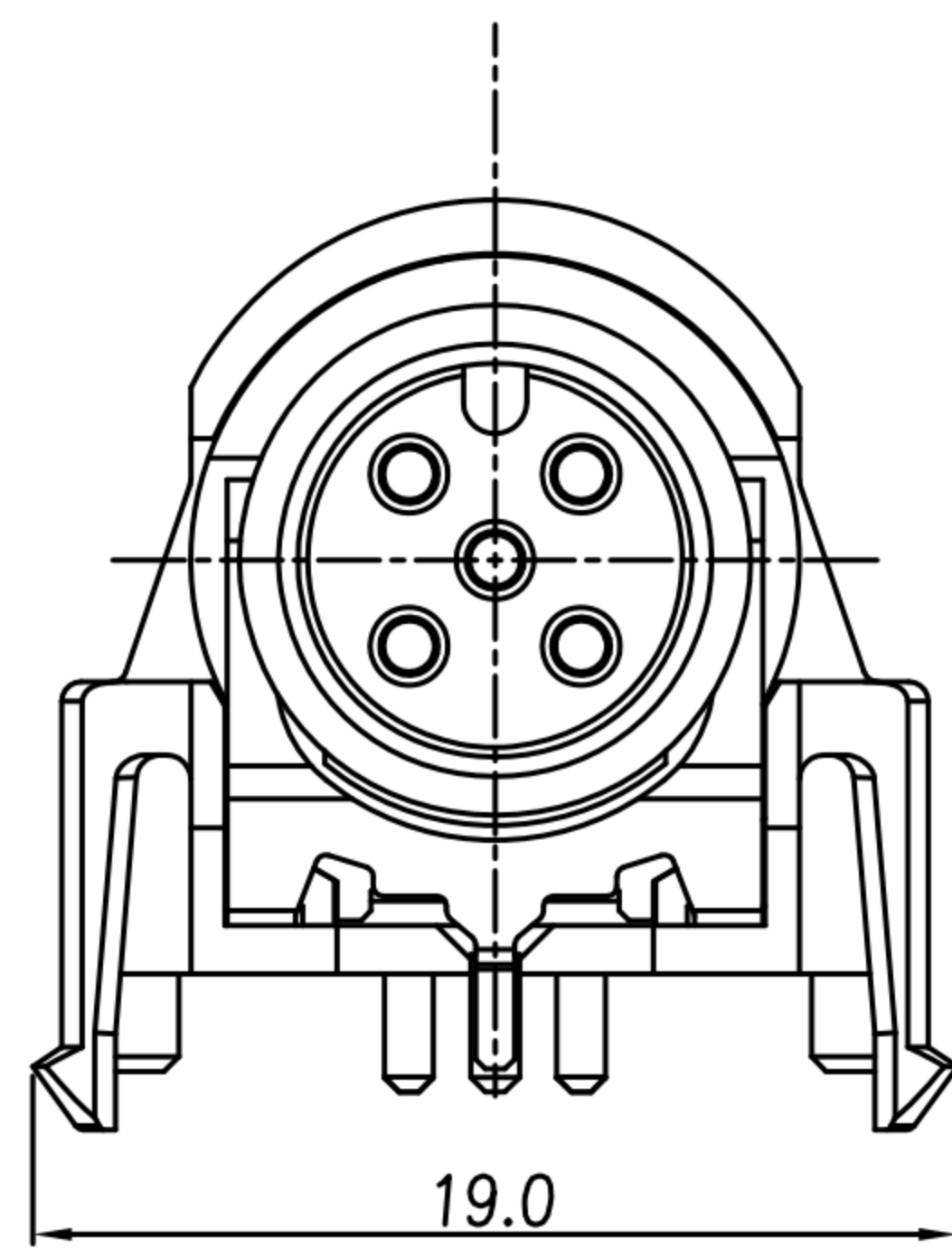

TABLE A

WP-04F2-298-11	WP-05F2-243-11

1. MATERIAL :
 - 1-1. HOUSING : PA9T
 - 1-2. CONTACT : BRASS
 - 1-3. O-RING : VITON
 - 1-4. BACK HOUSING : PA9T
 - 1-5. DOWN HOUSING : PA9T
 - 1-6. GROUND : PHOSPHOR BRONZE
2. FINISH :
 - 2-1. CONTACT : GOLD FLASH PLATED.
 - 2-2. GROUND : NICKEL PLATED.
3. ELECTRICAL SPECIFICATION :
 - 3-1. Rated current : 4A
 - 3-2. Rated Voltage : 4PIN 250V ;5PIN 60V
 - 3-3. Water proof : IP67 (in mated condition)
4. Environmental :
 - 4-1. Operation Temperature : $-25^{\circ}\text{C}\sim 85^{\circ}\text{C}$

DRAWN	LED	APP'D	Ku Chou	UNIT	mm	TOLERANCE		广东科斯达电子科技有限公司 GUANG DONG KE SI DA ELECTRONIC TECHNOLOGY CO., LTD.	TITLE	WP M12 A-CODING (F) Two-piece 90度			SHEET
CHK'D	Ku Chou			SCALE	1:1	.x ± 0.20 .xx ± 0.10 .xxx ± 0.05 .xxxx ± 0.03 ANGULAR $\pm 1^{\circ}$			PART NO.	TABLE A	DWG NO.	QC10812	VERSION