

CUSTOMER DRAWING

REV.	DESCRIPTION	APPVL. BY	DATE	ECN NO.
A	RELEASE	LED	14/05/21'	
B				
C				

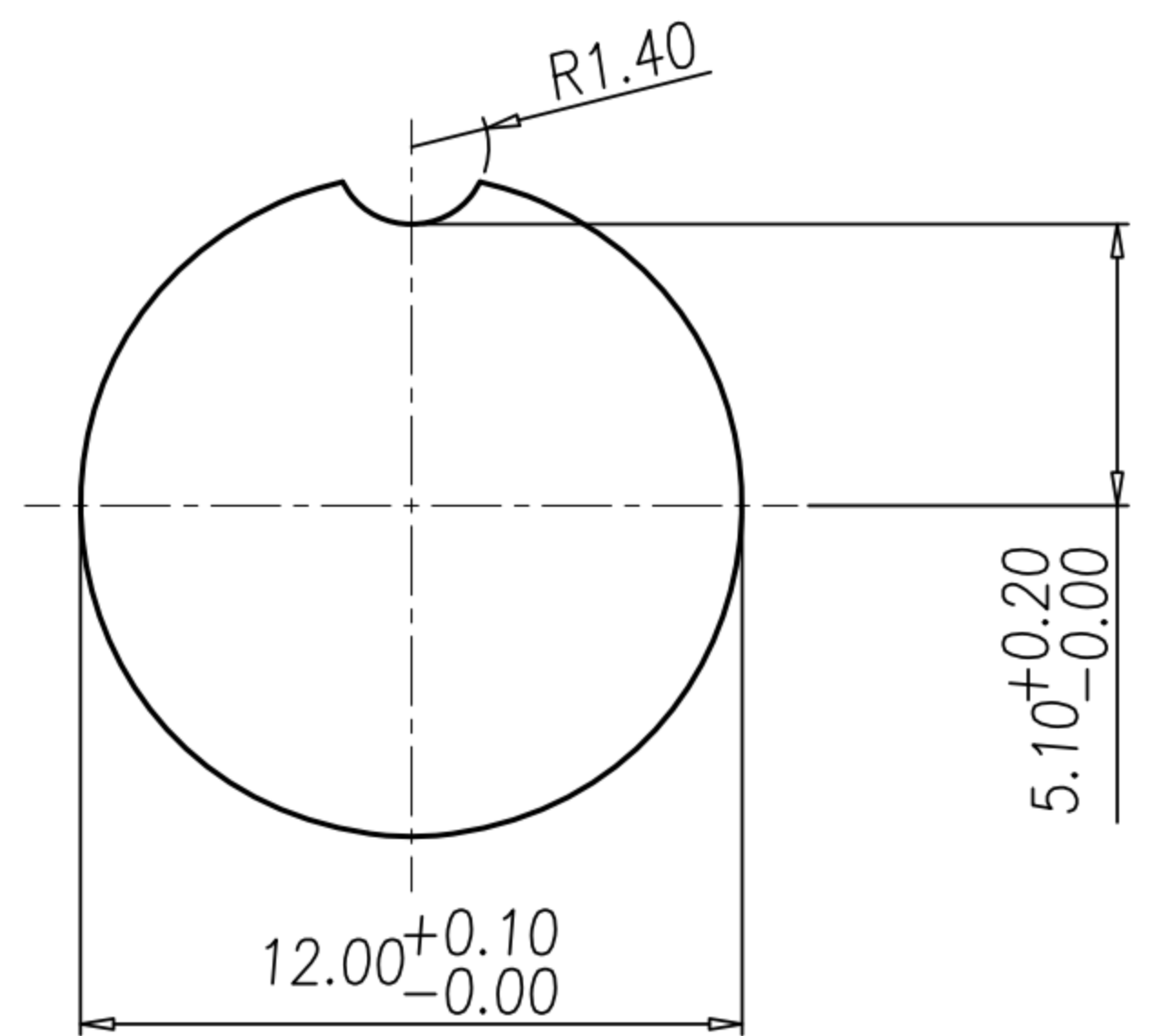
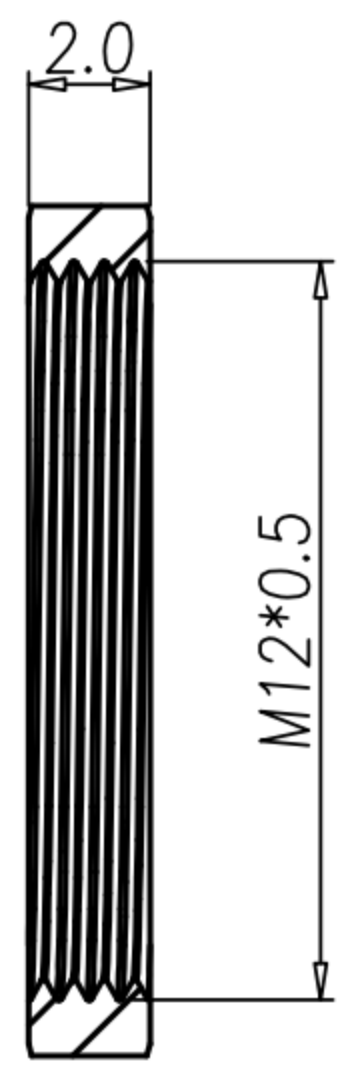
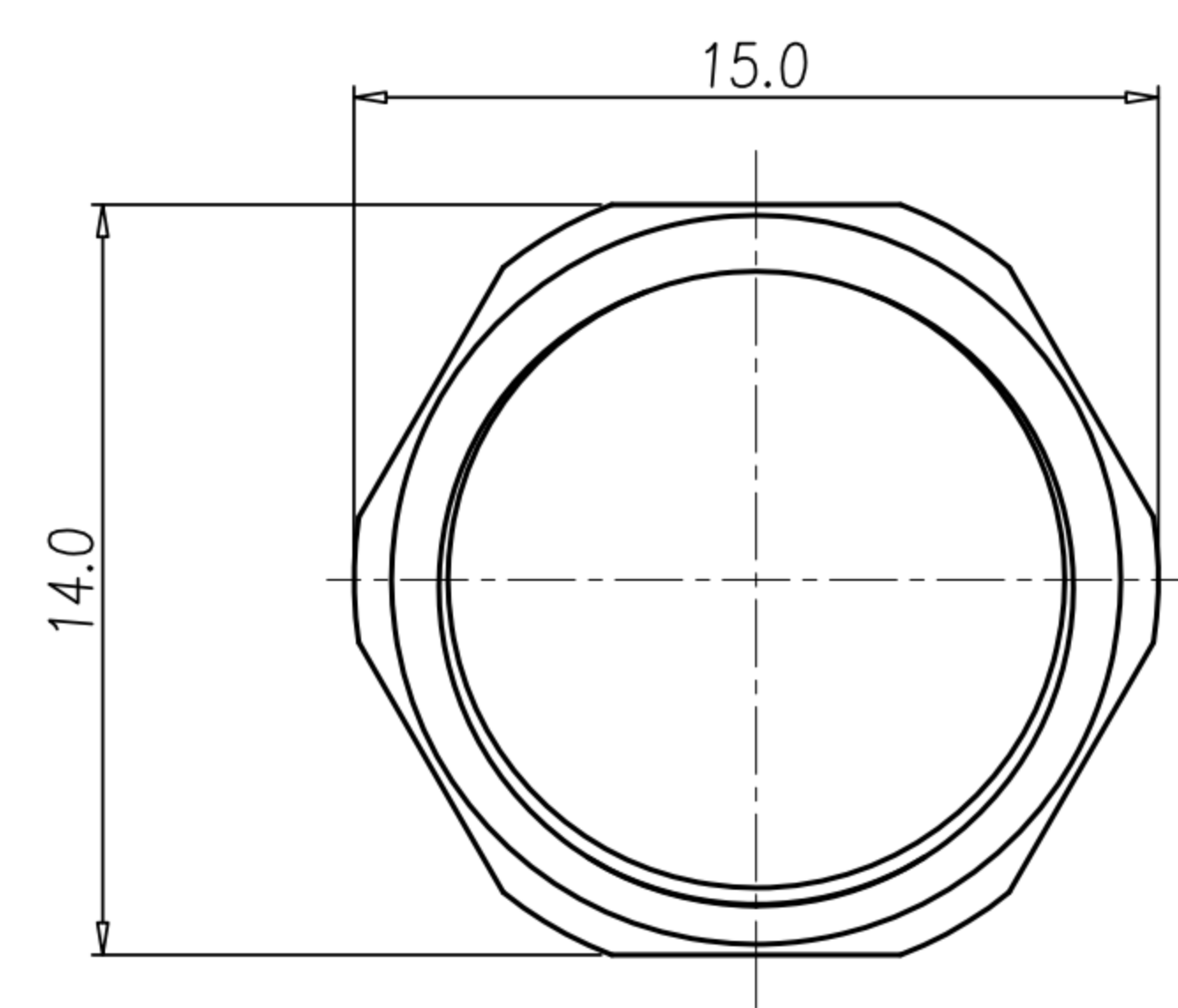
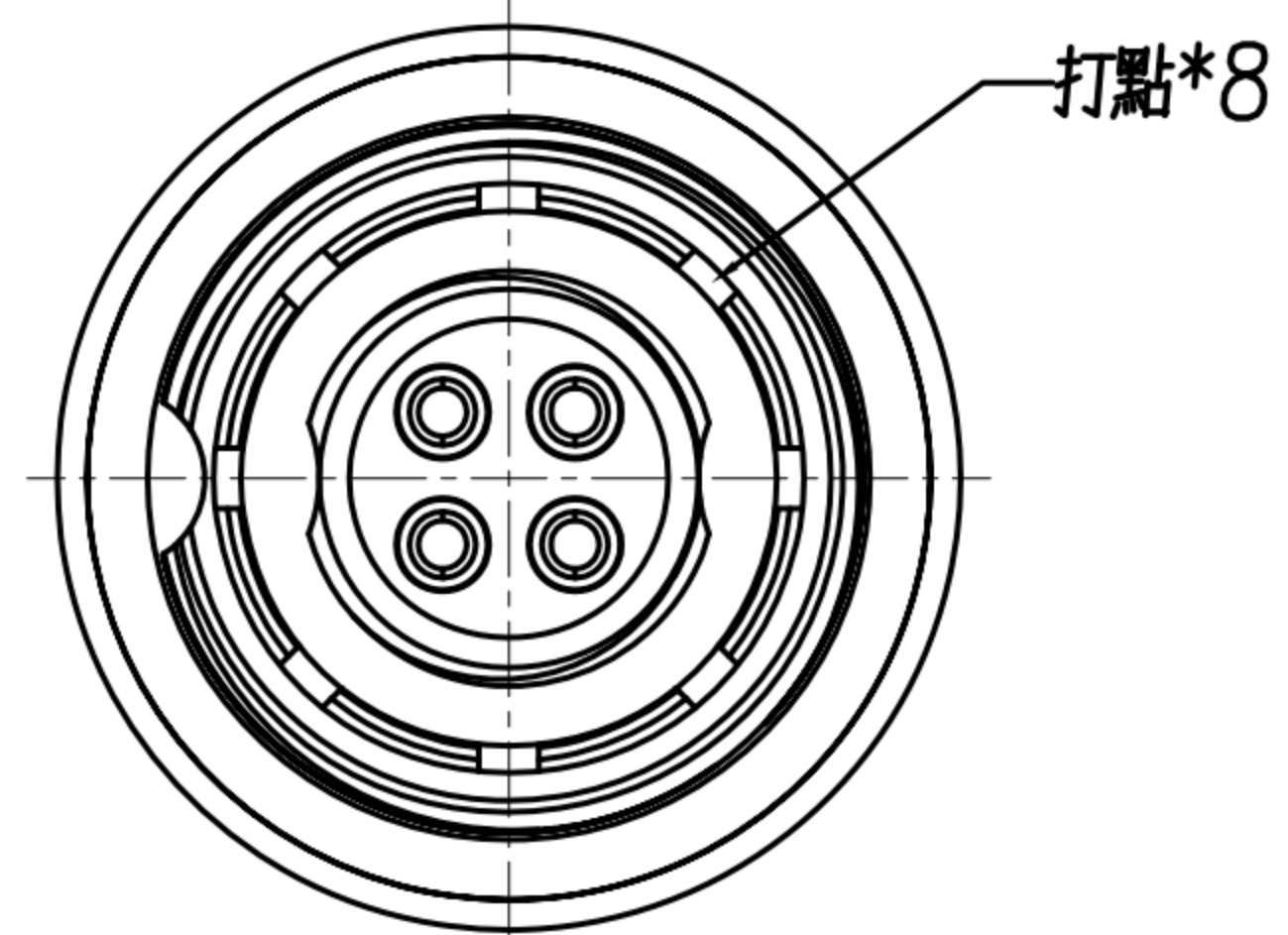
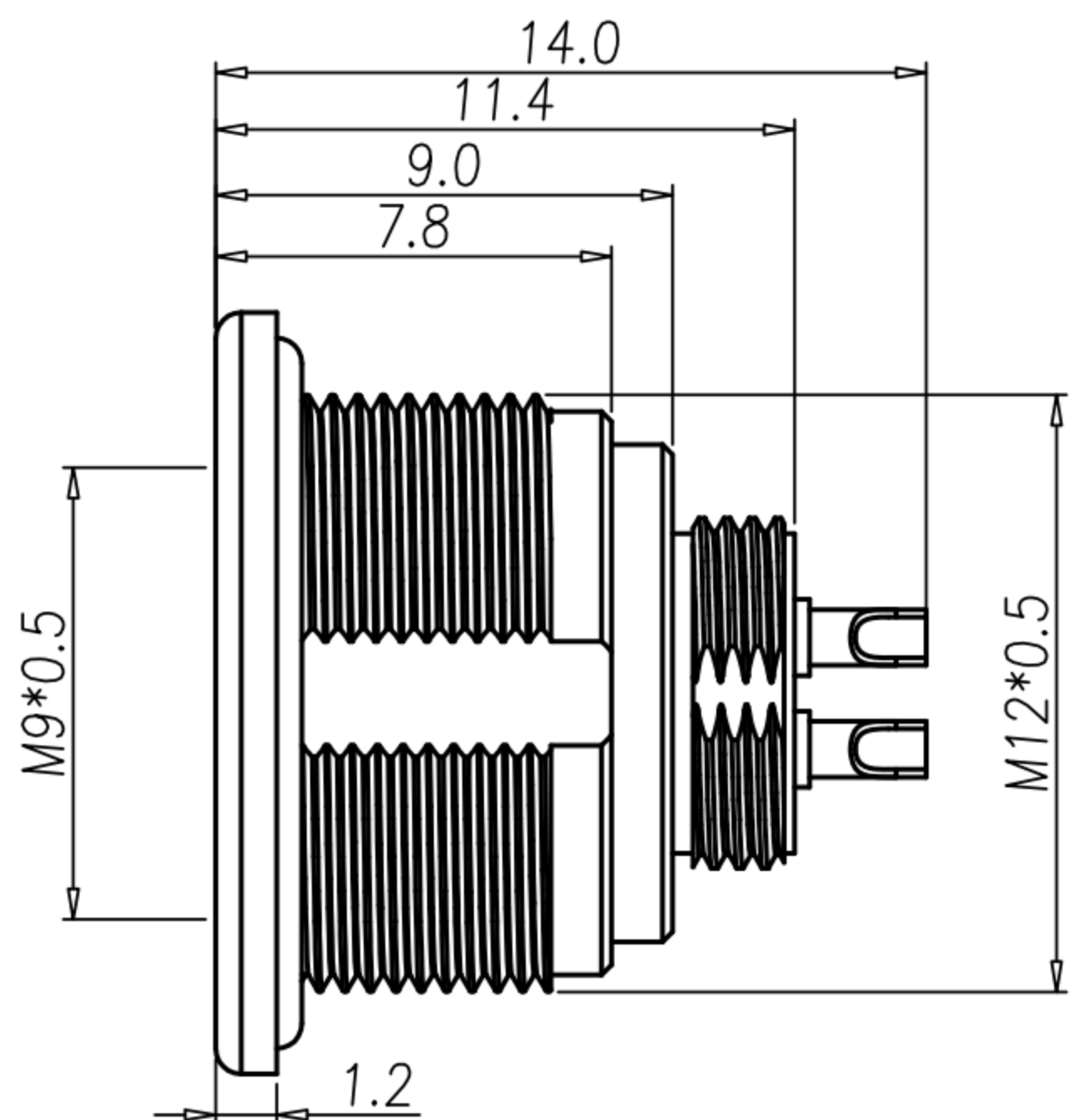
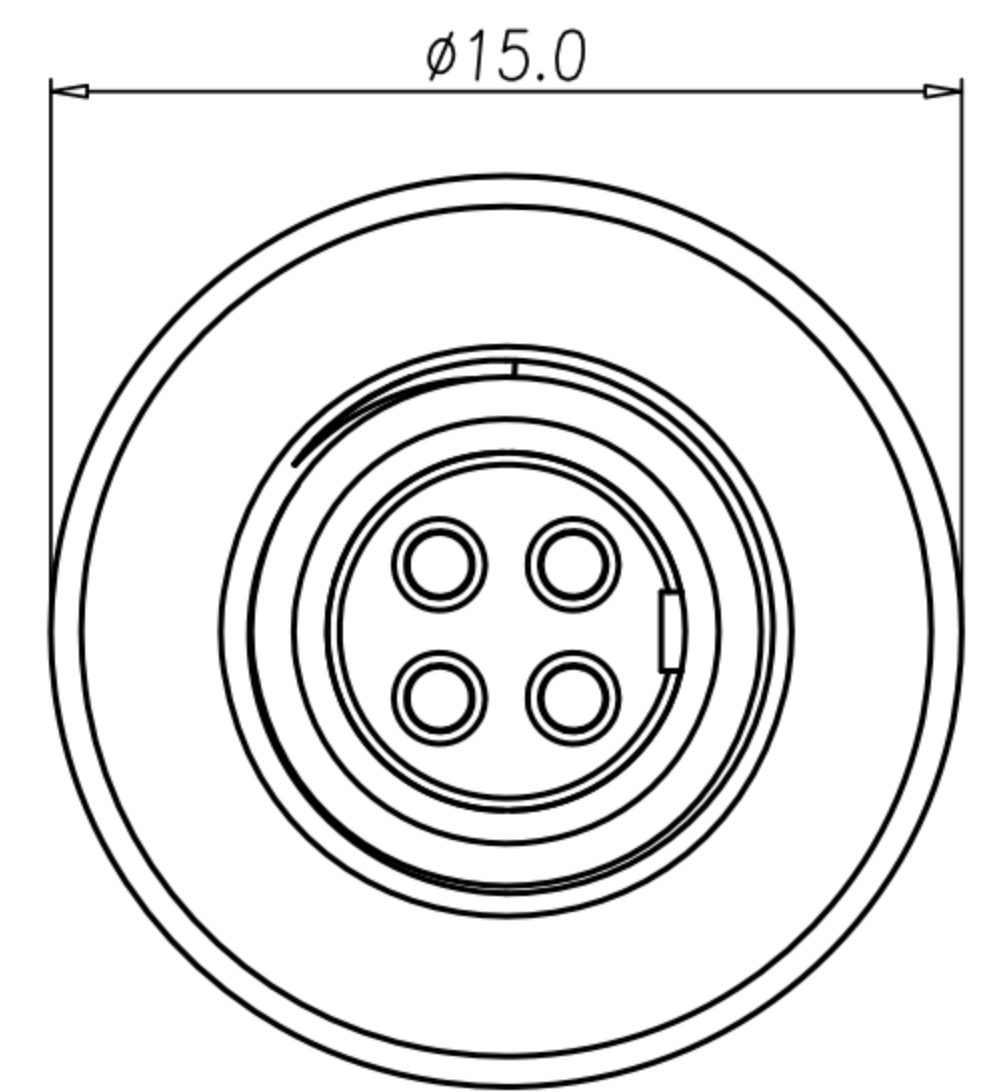

- MATERIAL :
 - 1-1. HOUSING : PA UL94V-0 ; COLOR : BLACK
 - 1-2. CONTACT : BRASS.
 - 1-3. SHELL : BRASS.
 - 1-4. O-RING A : SILICONE ; COLOR : BLACK.
 - 1-5. O-RING B : EPDM ; COLOR : BLACK.
 - 1-6. NUT : BRASS
- FINISH :
 - 2-1. CONTACT : GOLD FLASH
 - 2-2. SHELL : NICKEL PLTAEED.
 - 2-3. NUT : NICKEL PLTAEED.
- ELECTRICAL SPECIFICATION :
 - 3-1. Rated current(40℃) : 2~3P 4A; 4~5P 3A; 7~8P 1A
 - 3-2. Rated Voltage : 125V
 - 3-3. Water proof : IP67
- Environmental :
 - 4-1. Operation Temperature : -40℃~85℃

NUT

RECOMMEND PANEL CUT-OUT

WP-02F2-99-11	WP-03F2-168-11	WP-04F2-278-11	WP-05F2-211-11	WP-07F2-20-11	WP-08F2-131-11

DRAWN	LED	APP'D	Ku Chou	UNIT	mm	TOLERANCE		广东科斯达电子科技有限公司 GUANG DONG KE SI DA ELECTRONIC TECHNOLOGY CO., LTD.	TITLE	WP M9 (F) M12 檢驗試			SHEET
CHK'D	Ku Chou			SCALE	1:1	.x ±0.20 .xx ±0.10 .xxx ±0.05 .xxxx ±0.03 ANGULA ±1°			PART NO.	SEE TABLE A	DWG NO.	QC10189	VERSION