

CUSTOMER DRAWING

REV.	DESCRIPTION	APPVL. BY	DATE	ECN NO.
A	RELEASE	Fido Weng	18/02/14*	
B				
C				

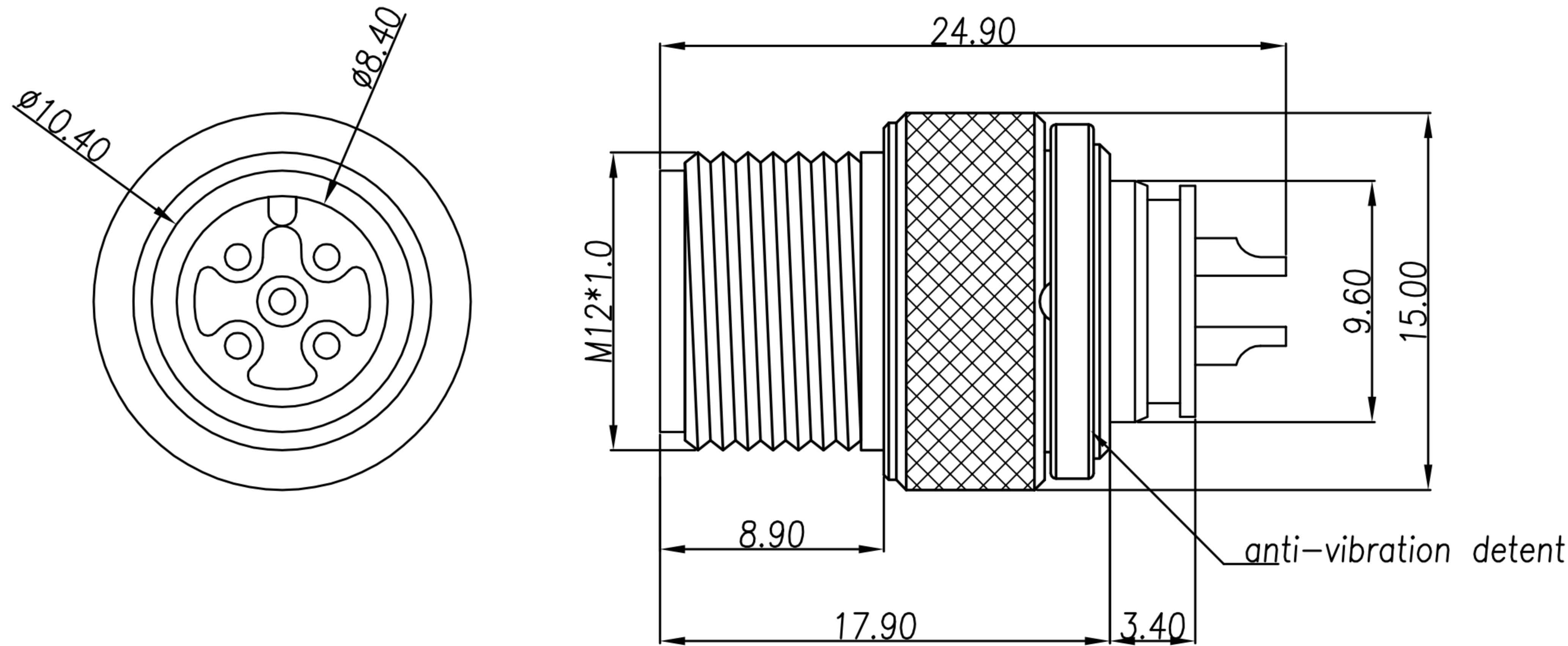

WP-05M2-79-11	WP-05M2-88-11	WP-04M2-141-11	WP-03M2-80-11
WP-05M2-111-11			

- MATERIAL :
  - 1-1. HOUSING : PA66 ; COLOR : BLACK
  - 1-2. CONTACT : BRASS
  - 1-3. NUT : SEE TABLE A
- FINISH :
  - 2-1. CONTACT : SEE TABLE A
  - 2-2. SHELL : SEE TABLE A
- ELECTRICAL SPECIFICATION :
  - 3-1. Rated current : 4A
  - 3-2. Rated Voltage : 3~4PIN 250V ; 5PIN 60V
  - 3-3. Water proof : IP68
- Environmental :
  - 4-1. Operation Temperature : -40°C~105°C

TABLE A/表A

WP-03M2-80-11	BRASS/NICKEL PLATED.	GOLD 10u"
WP-04M2-141-11	BRASS/NICKEL PLATED.	GOLD 10u"
WP-05M2-111-11	BRASS/NICKEL PLATED.	GOLD 10u"
WP-05M2-88-11	STAINLESS STEEL 303.	GOLD FLASH
WP-05M2-79-11	BRASS/NICKEL PLATED.	GOLD FLASH
PART NO.	NUT MATERIAL	CONTACT PLATED

DRAW	Ku Chou	APPVL	Emily Suen	UNIT	mm	TOLERANCE		广东科斯达电子科技有限公司 GUANG DONG KE SI DA ELECTRONIC TECHNOLOGY CO., LTD.	TITLE	防水頭 M12 (M)A-CODE 止滑線式			SHEET	1
CHECK	Emily Suen			SCALE	1:1	.x ±0.20 .xx ±0.10 .xxx ±0.05 .xxxx ±0.03 ANGULA ±1°			PART NO.	SEE TABLE A	DWG NO.	QC6587	VERSION	A