

CUSTOMER DRAWING

REV.	DESCRIPTION	APPROVED BY	DATE	ECN NO.
△A	RELEASE	Fido Weng	10/01/11'	
△B	ADD TABLE A	Ku Chou	25/05/18'	
△C				

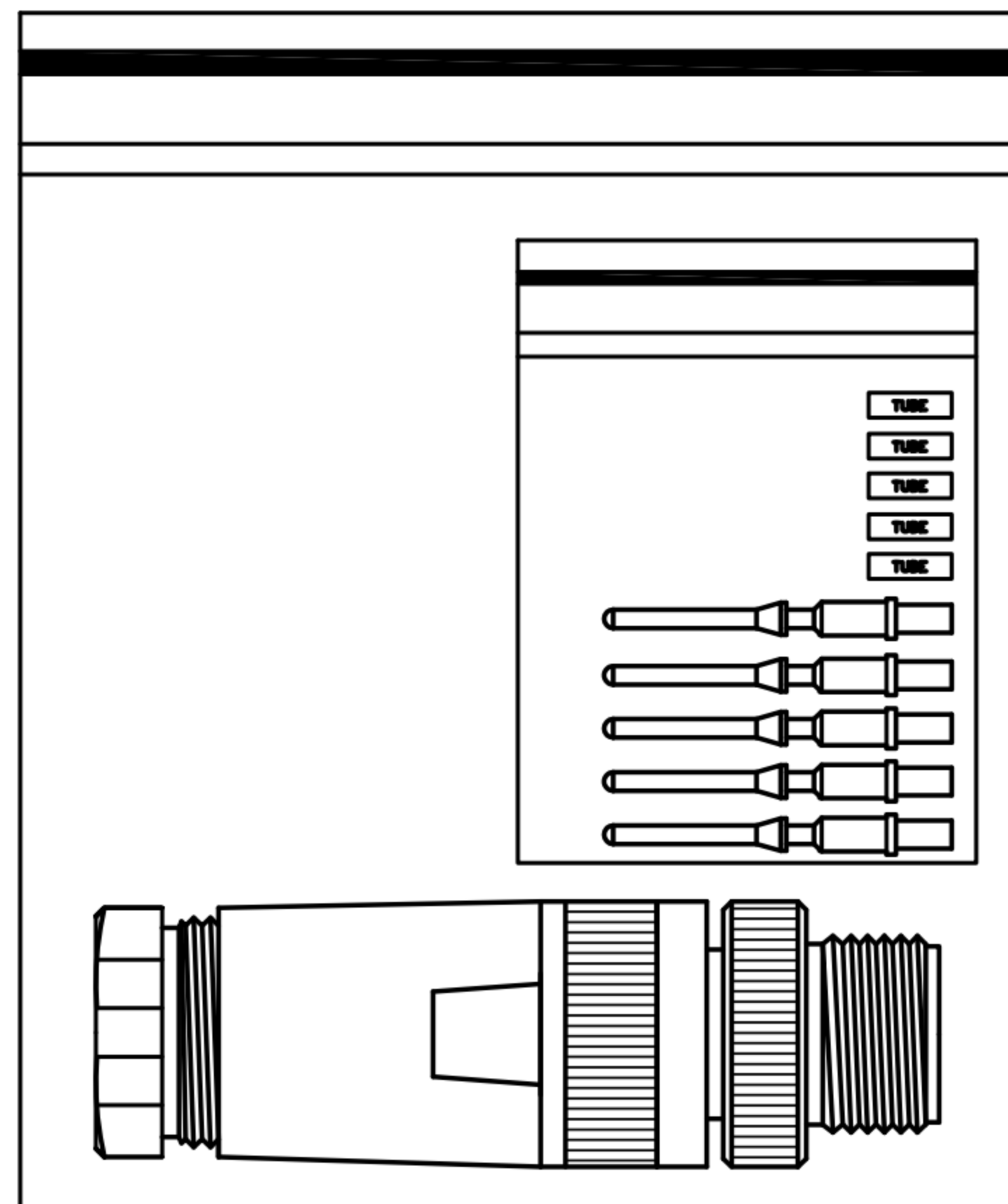

PACKAGE

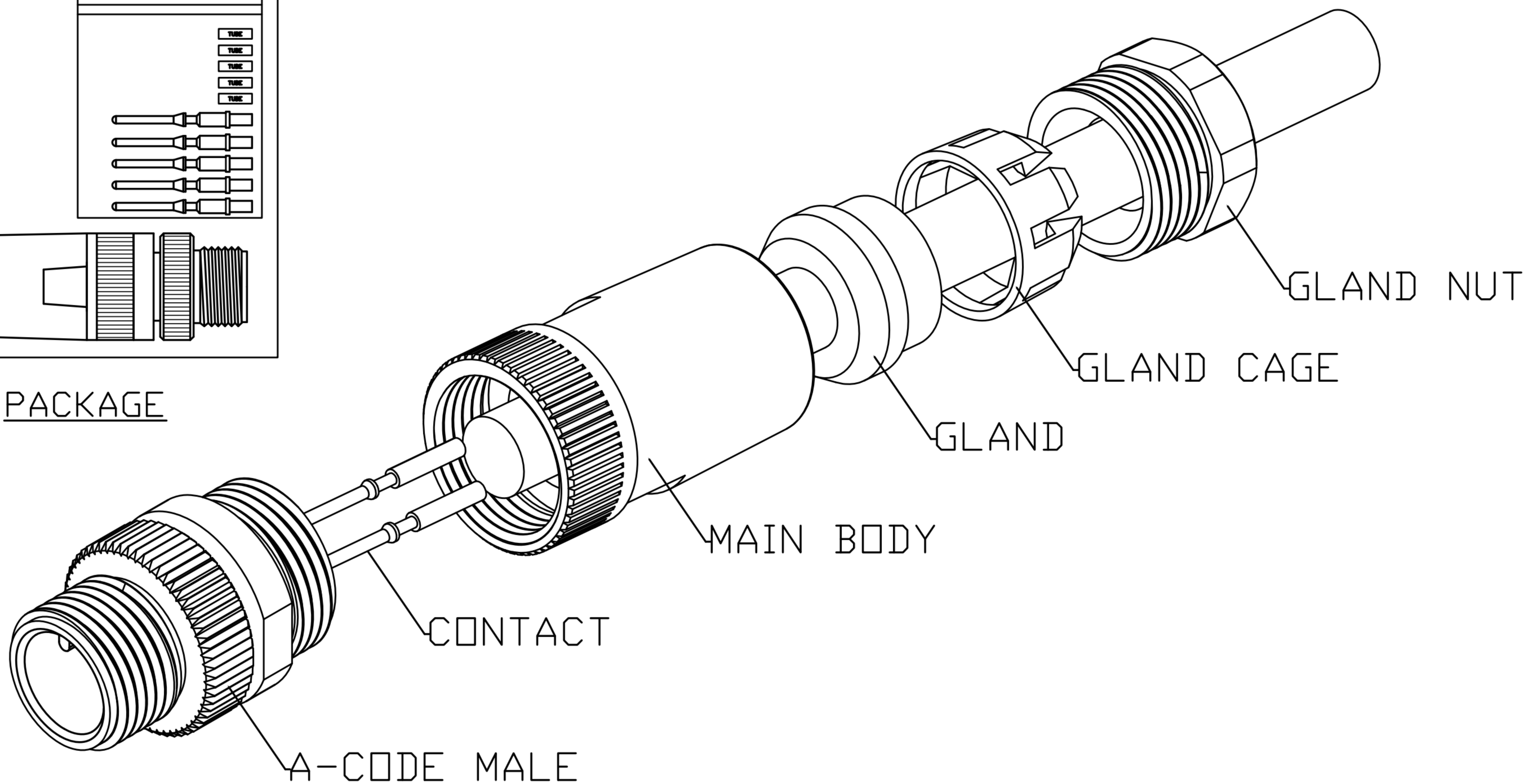

DRAWN	Emily Suen	APP'D	Ku Chou	UNIT	mm	TOLERANCE		广东科斯达电子科技有限公司 GUANG DONG KE SI DA ELECTRONIC TECHNOLOGY CO., LTD.	TITLE	M12 (M) A-CODE CRIMP PIN TYPE			SHEET	2
CHK'D	Ku Chou			SCALE	1:1	.x ±0.20 .xx ±0.10 .xxx ±0.05 .xxxx ±0.03 ANGULA ±1°			PART NO.	SEE TABLE A	DWG NO.	QC7499	VERSION	B

CUSTOMER DRAWING

REV.	DESCRIPTION	APPROVED BY	DATE	ECN NO.
A	RELEASE	Fido Weng	10/01/11'	
B	ADD TABLE A	Fido Weng	25/05/18'	
C				

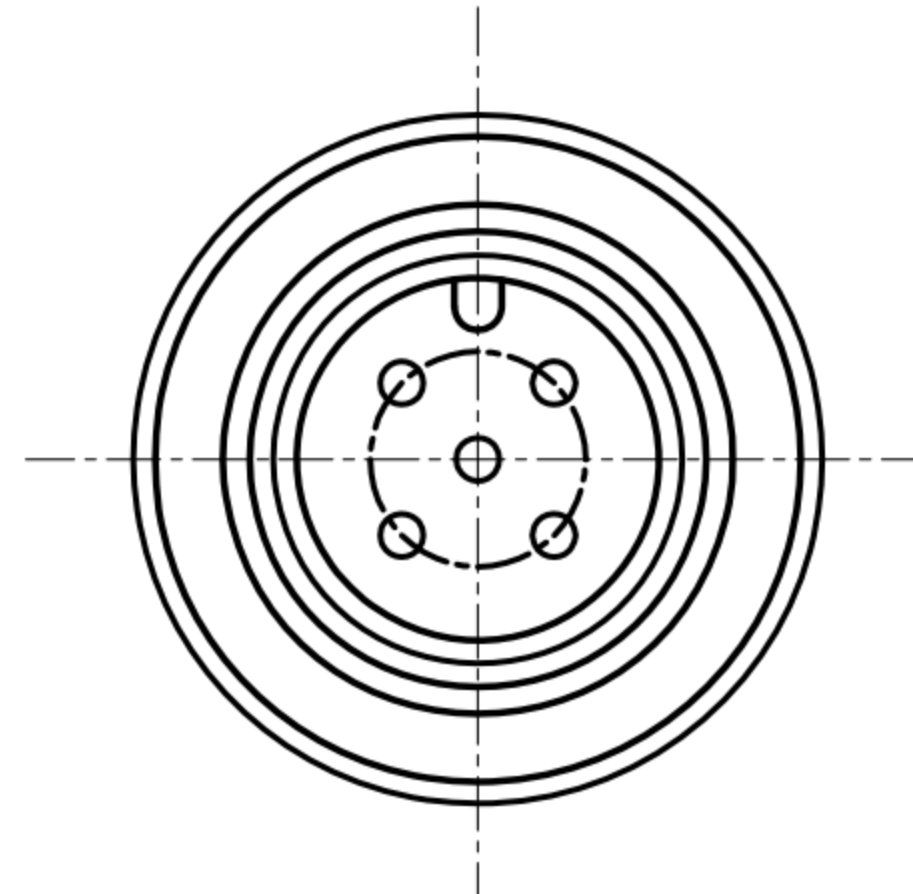
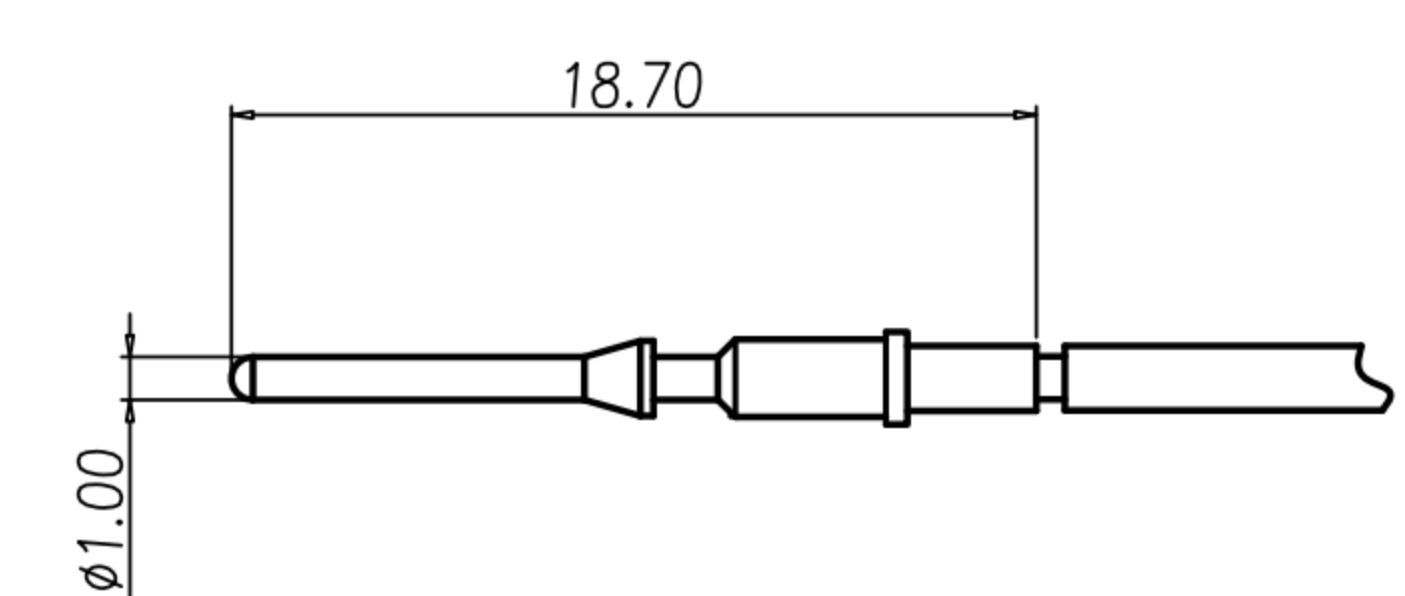
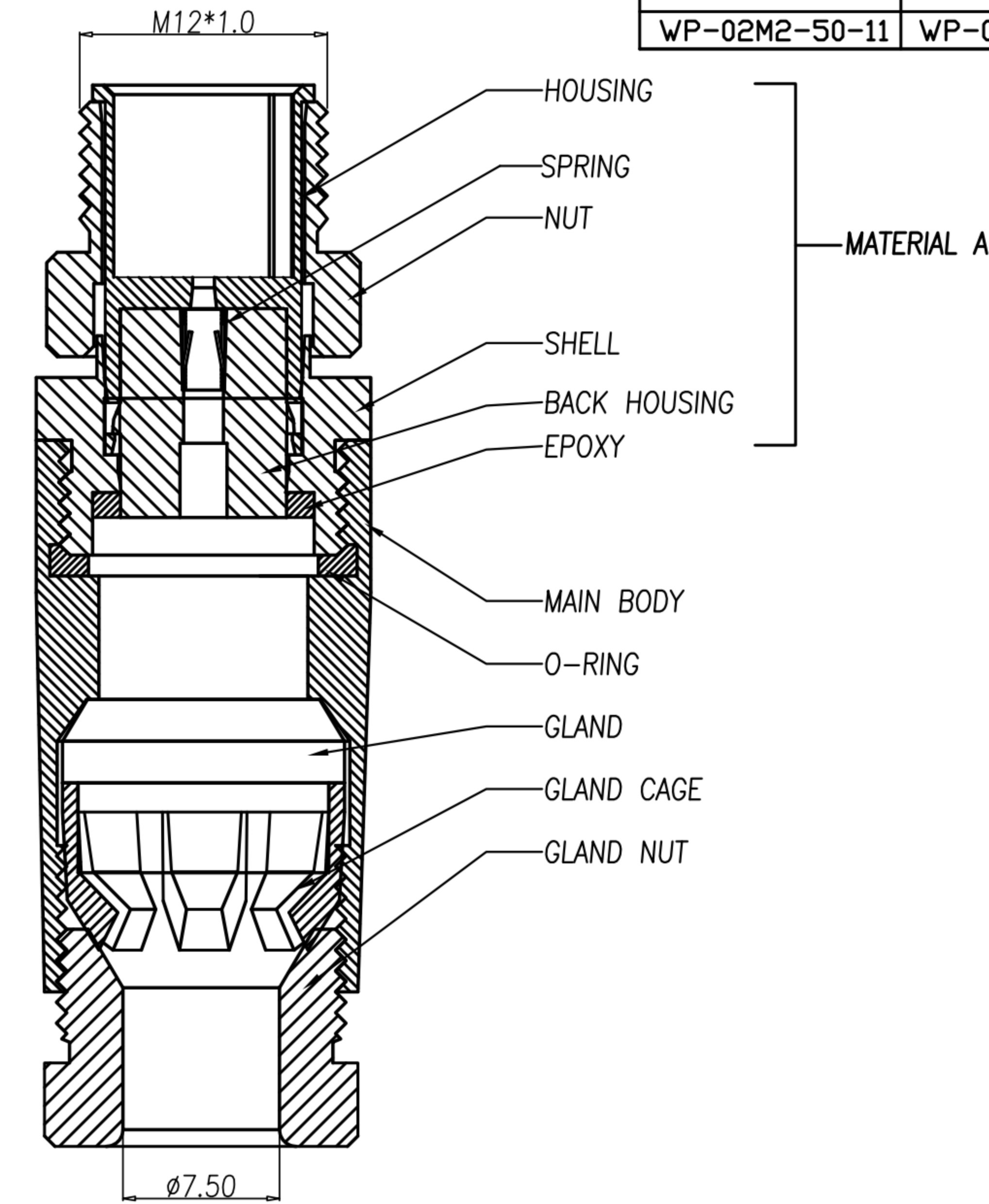
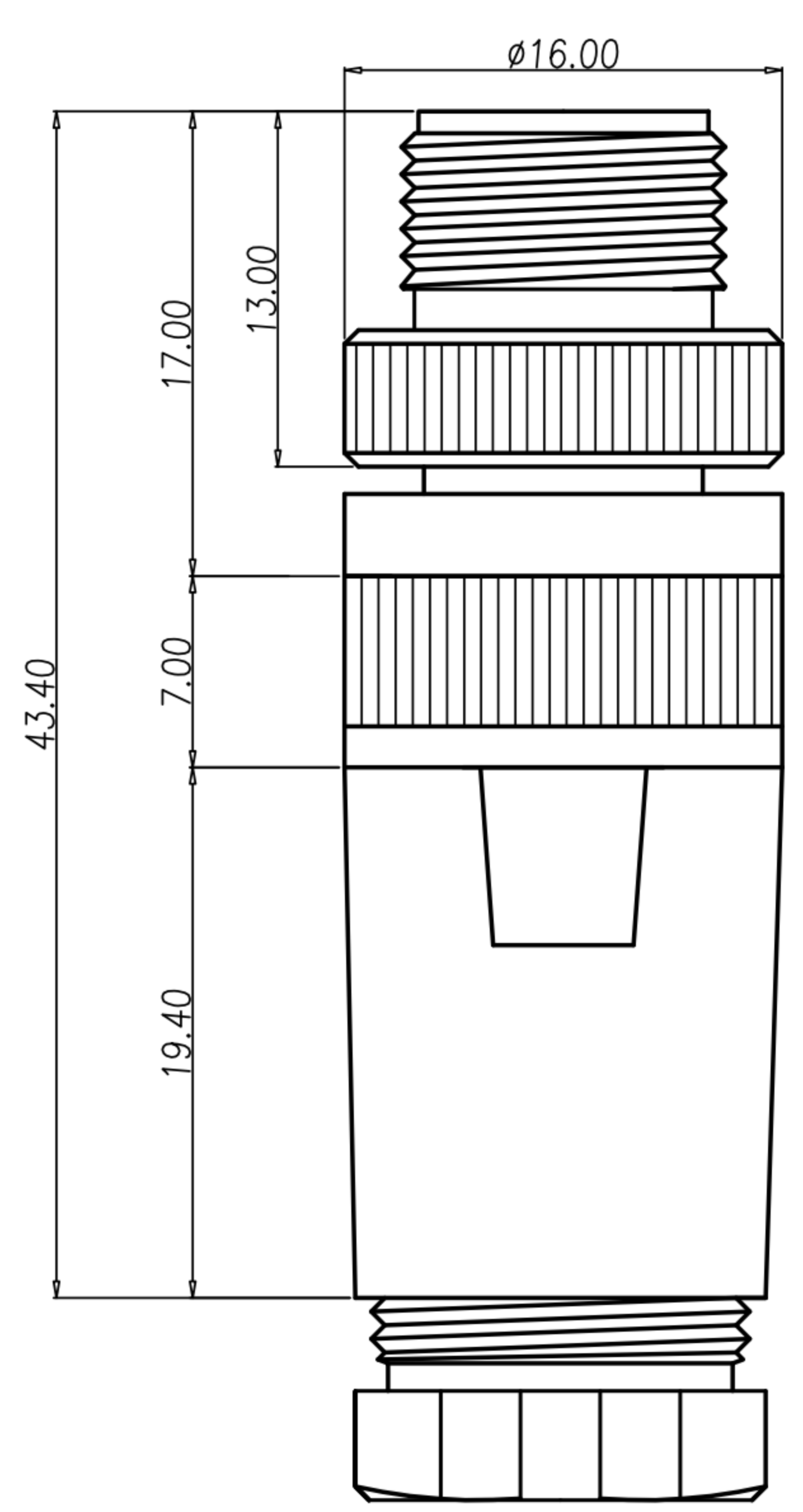

TABLE A

WP-04M2-154-11	WP-05M2-110-11
WP-02M2-50-11	WP-03M2-85-11



CONTACT ASS'Y FOR 24AWG~28AWG



1. MATERIAL :
 - 1-1. MATERIAL A :
 - a. HOUSING : PBT UL94V-0 ; COLOR : BLACK.
 - b. CONTACT : BRASS
 - c. NUT : ALUMINIUM ALLOY
 - d. SHELL : ALUMINIUM ALLOY
 - e. BACK HOUSING : PBT UL94V-0 ; COLOR : BLACK.
 - f. SPRING : BERYLLIUM COPPER
 - 1-2. MAIN BODY : ALUMINIUM ALLOY
 - 1-3. GLAND : SILICONE ; COLOR : BLACK.
 - 1-4. GLAND CAGE : POM ; COLOR : BLACK.
 - 1-5. GLAND NUT : ALUMINIUM ALLOY
 - 1-6. O-RING : SILICONE ; COLOR : BLACK
2. FINISH :
 - 2-1. MATERIAL A :
 - a. CONTACT : GOLD FLASH MICRO INCHES MIN.
UNDER PLATE : NICKEL.
 - b. NUT : SATIN NICKEL PLATED.
 - c. SHELL : SATIN NICKEL PLATED.
 - d. SPRING : NICKEL PLATED.
 - 2-2. MAIN BODY : SATIN NICKEL PLATED.
 - 2-3. GLAND NUT : SATIN NICKEL PLATED.
3. ELECTRICAL SPECIFICATION :
 - 3-1. Rated current : 4A
 - 3-2. Rated voltage : 2~4PIN 250V;5PIN 60V
 - 3-3. Water proof : IPX7
4. Environmental :
 - 4-1. Operation Temperature : -20℃~85℃

DRAWN	Emily Suen	APP'D	Ku Chou	UNIT	mm	TOLERANCE		广东科斯达电子科技有限公司 GUANG DONG KE SI DA ELECTRONIC TECHNOLOGY CO., LTD.	TITLE	M12 (M) A-CODE CRIMP PIN TYPE			SHEET	1/2
CHK'D	Ku Chou			SCALE	1:1	.x ±0.20 .xx ±0.10 .xxx ±0.05 .xxxx ±0.03 ANGULA ±1°			PART NO.	SEE TABLE A	DWG NO.	QC7499	VERSION	B