

CUSTOMER DRAWING

REV.	DESCRIPTION	APPVL. BY	DATE	ECN NO.
A	RELEASE	Fido Weng	25/02/14*	
B				
C				

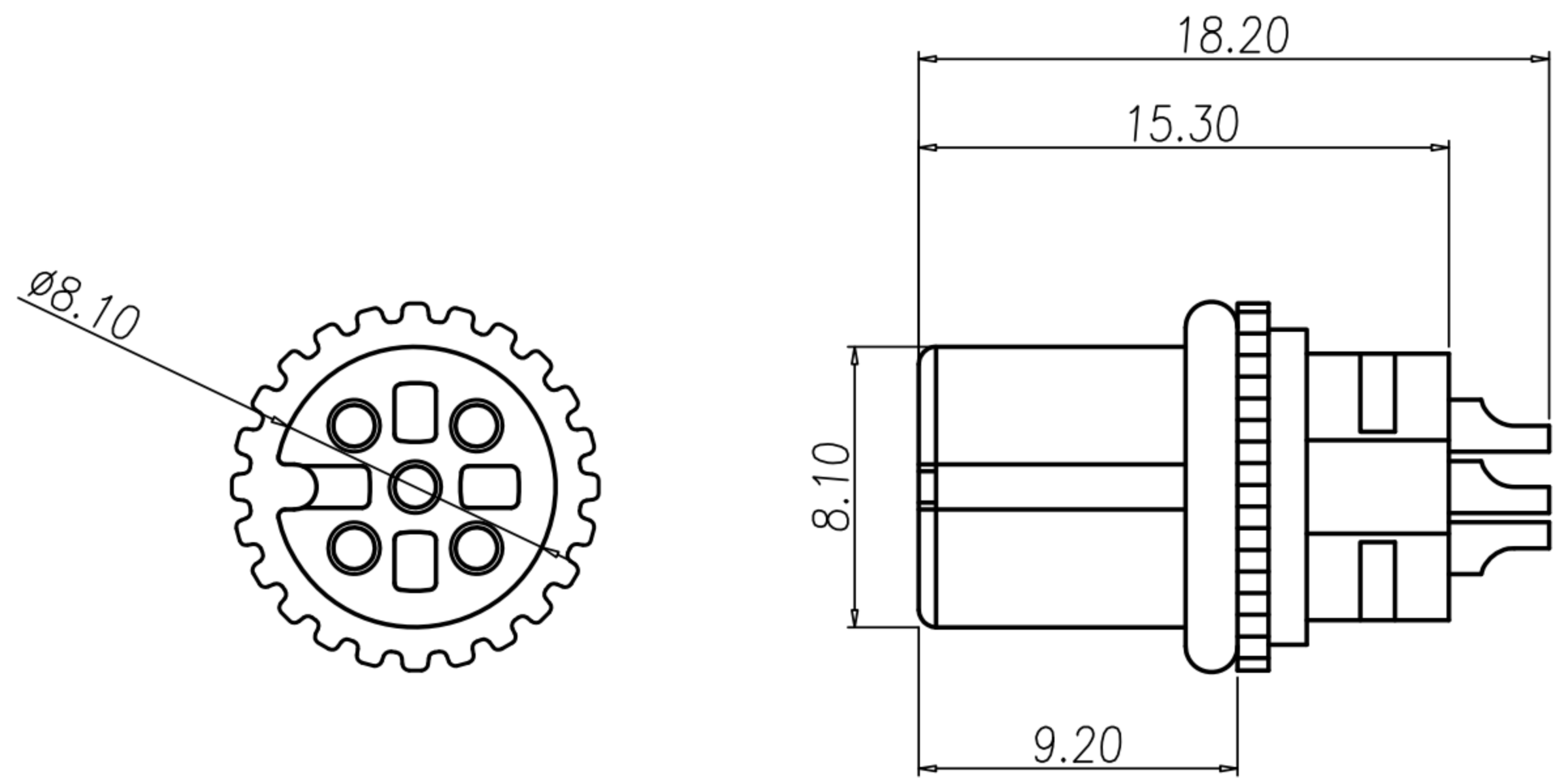

HPUSING & PIN & O-ring

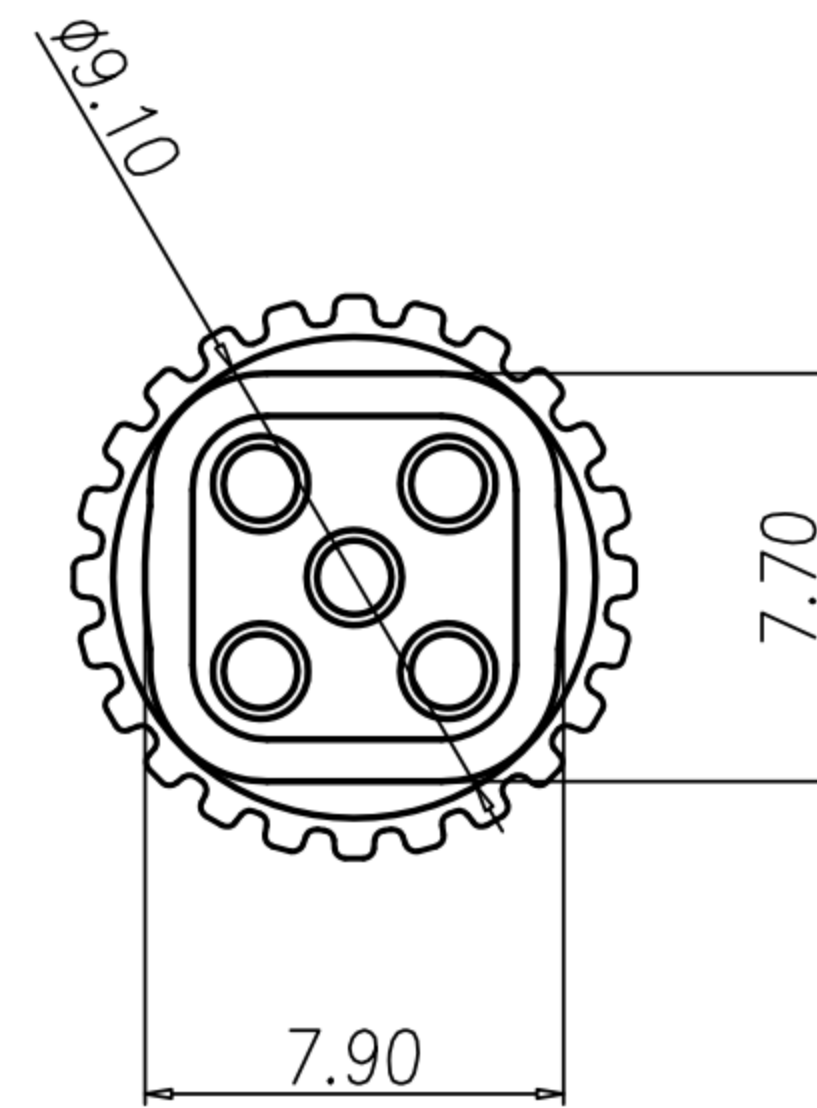
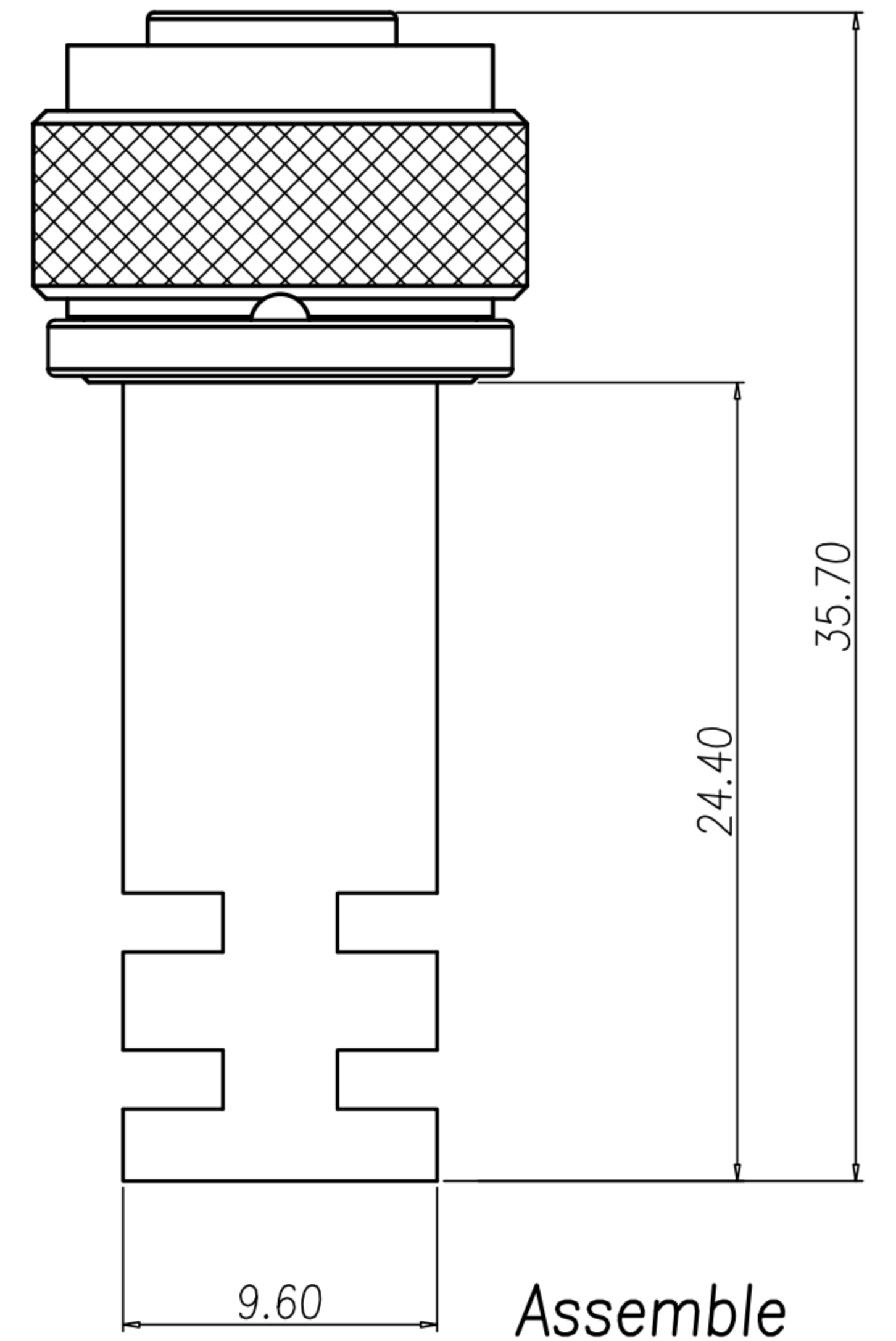
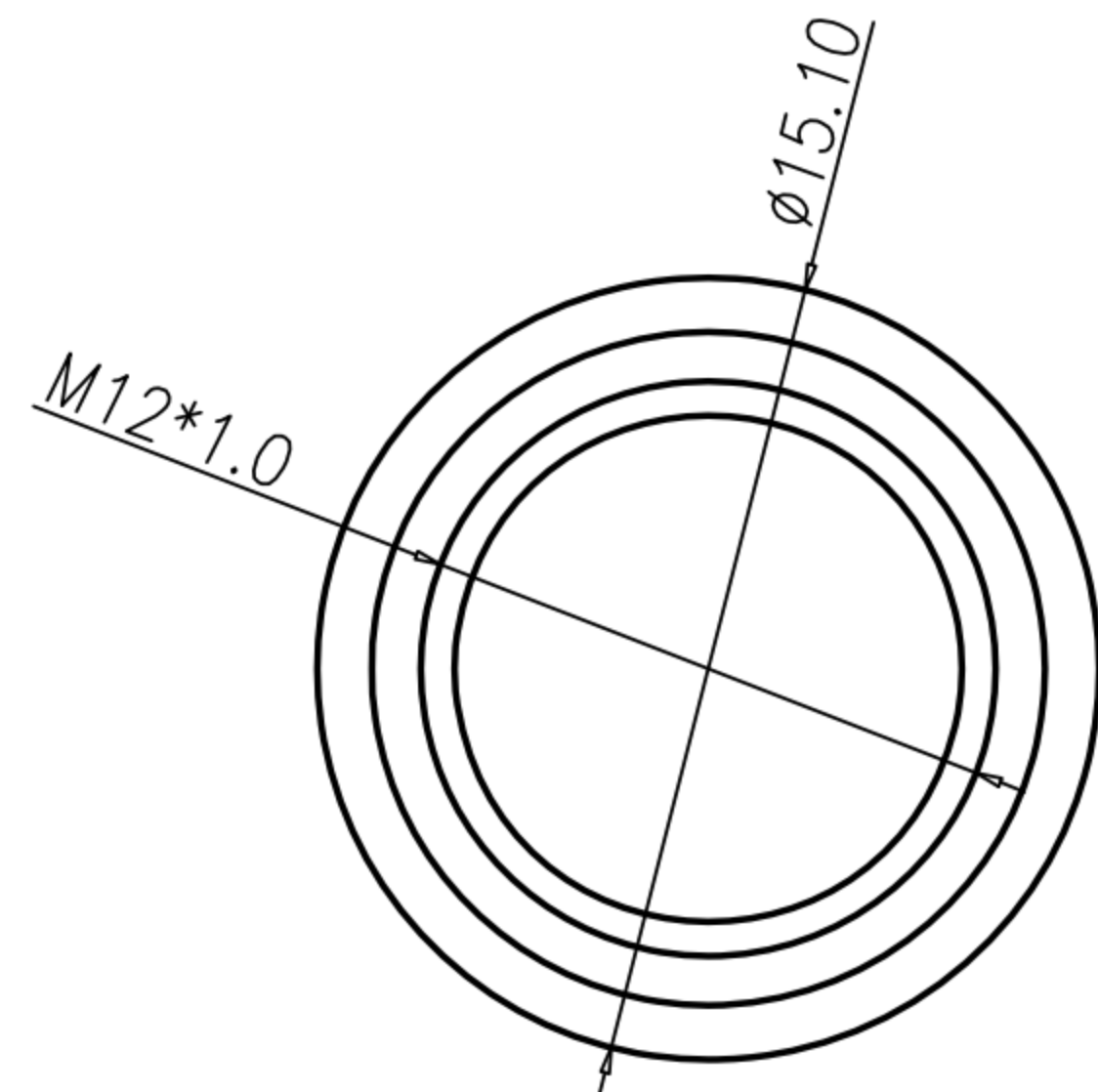

TABLE A

5P	4P
WP-05F2-209-11 WP-05F2-210-11	WP-04F2-276-11 WP-04F2-277-11
3P	2P
WP-03F2-166-11 WP-03F2-167-11	WP-02F2-97-11 WP-02F2-98-11



Assemble



NUT & anti-vibration detent

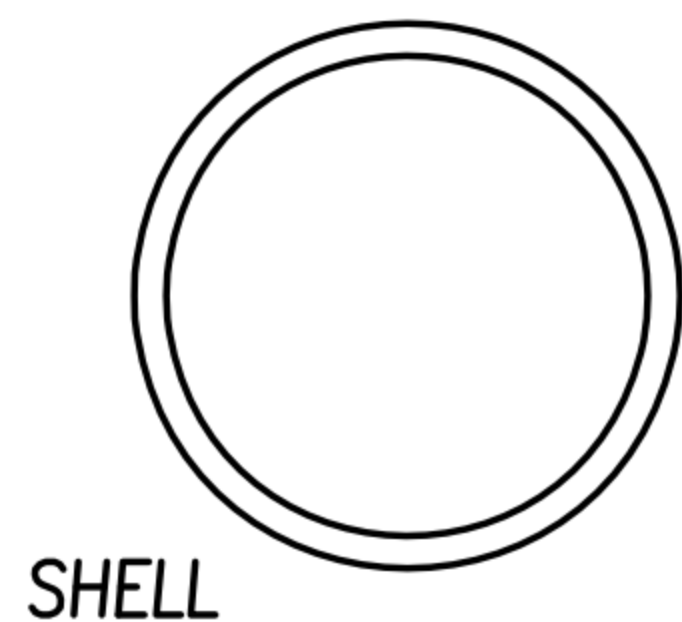
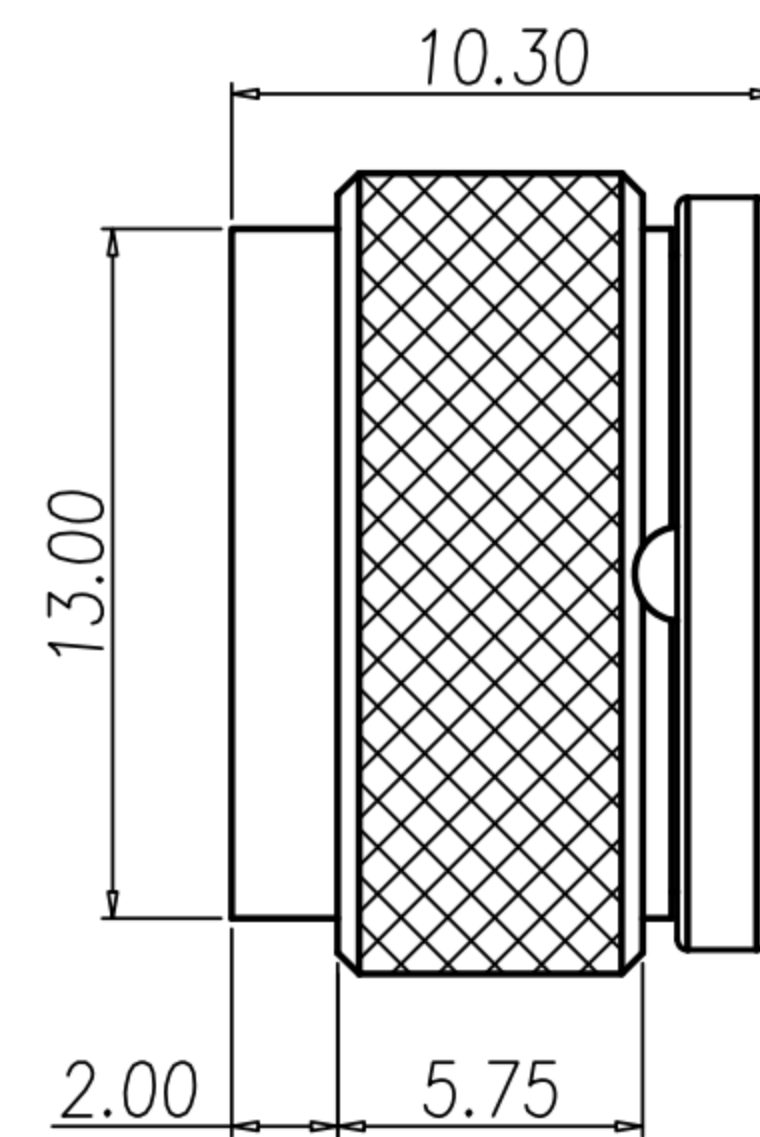

SHELL

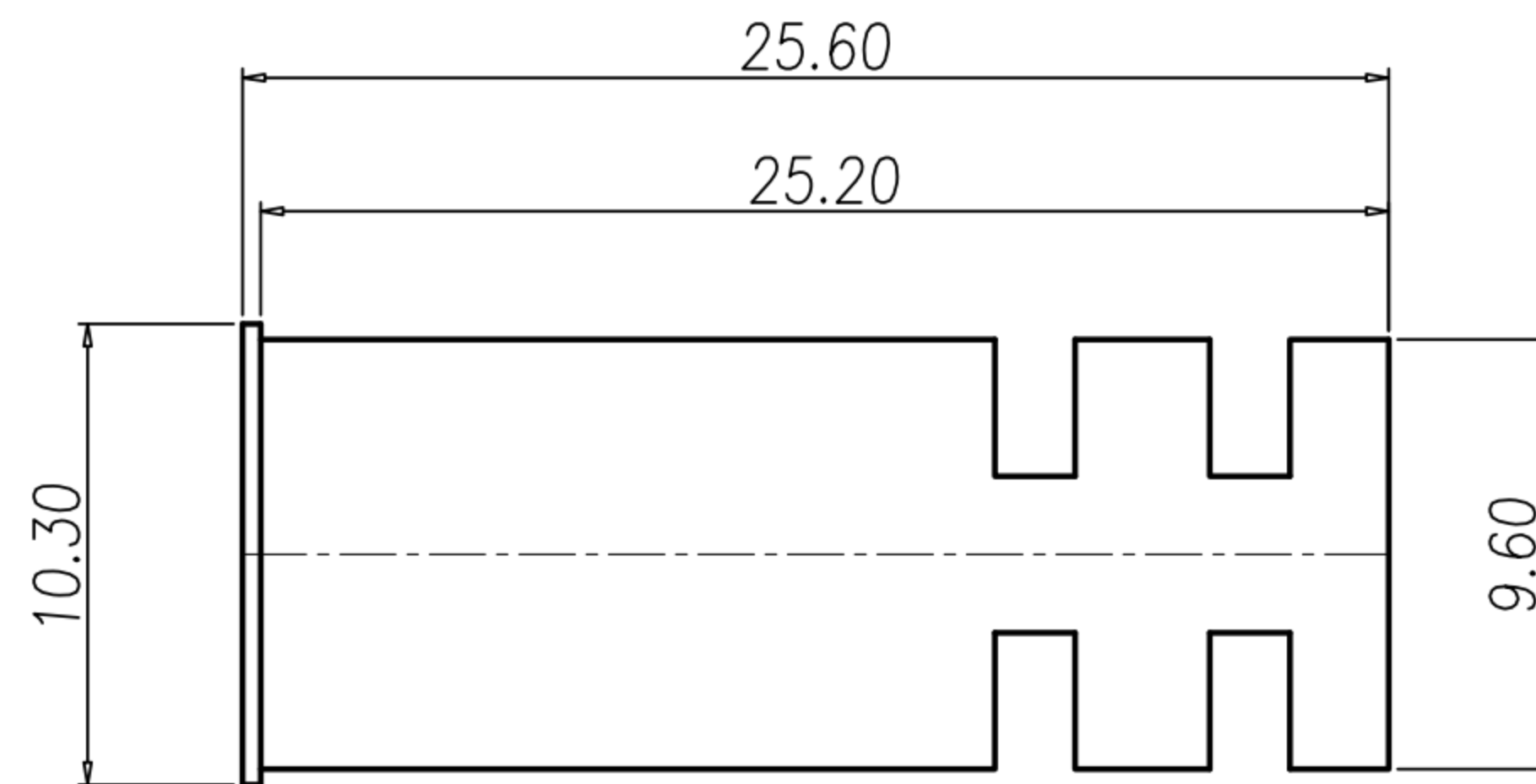

WP-02F2-97-11	GOLD FLASH	WP-02F2-98-11	GOLD 10u"
WP-03F2-166-11	GOLD FLASH	WP-03F2-167-11	GOLD 10u"
WP-04F2-276-11	GOLD FLASH	WP-04F2-277-11	GOLD 10u"
WP-05F2-209-11	GOLD FLASH	WP-05F2-210-11	GOLD 10u"
PART NO	FINISH	PART NO	FINISH

- MATERIAL :
 - HOUSING : PA66 ; COLOR : BLACK
 - CONTACT : BRASS
 - NUT : BRASS
 - SHELL : BRASS
 - O-RING : EPDM
- FINISH :
 - CONTACT : SEE TABLE A
UNDER PLATE : NICKEL
 - NUT : NICKEL PLATED.
 - SHELL : NICKEL PLATED.
- ELECTRICAL SPECIFICATION :
 - Rated current : 4A
 - Rated Voltage : 2~4PIN 250V ; 5PIN 60V
 - Water proof : IPX7
- Environmental :
 - Operation Temperature : -40℃~85℃

DRAW	Ku Chou	APPVL	Emily Suen	UNIT	mm	TOLERANCE			TITLE	防水頭 M12 (F) A-CODE 止滑接地焊線式			SHEET	1
CHECK	Emily Suen			SCALE	1:1				PART NO.	SEE TABLE A	DWG NO.	QC10166	VERSION	A

广东科斯达电子科技有限公司
GUANG DONG KE SI DA ELECTRONIC TECHNOLOGY CO., LTD.