

CUSTOMER DRAWING

REV.	DESCRIPTION	APPROVED BY	DATE	ECN NO.
A	RELEASE	Fido Weng	22/02/16*	
B	增加本色料號	KU	31/01/18*	
C				

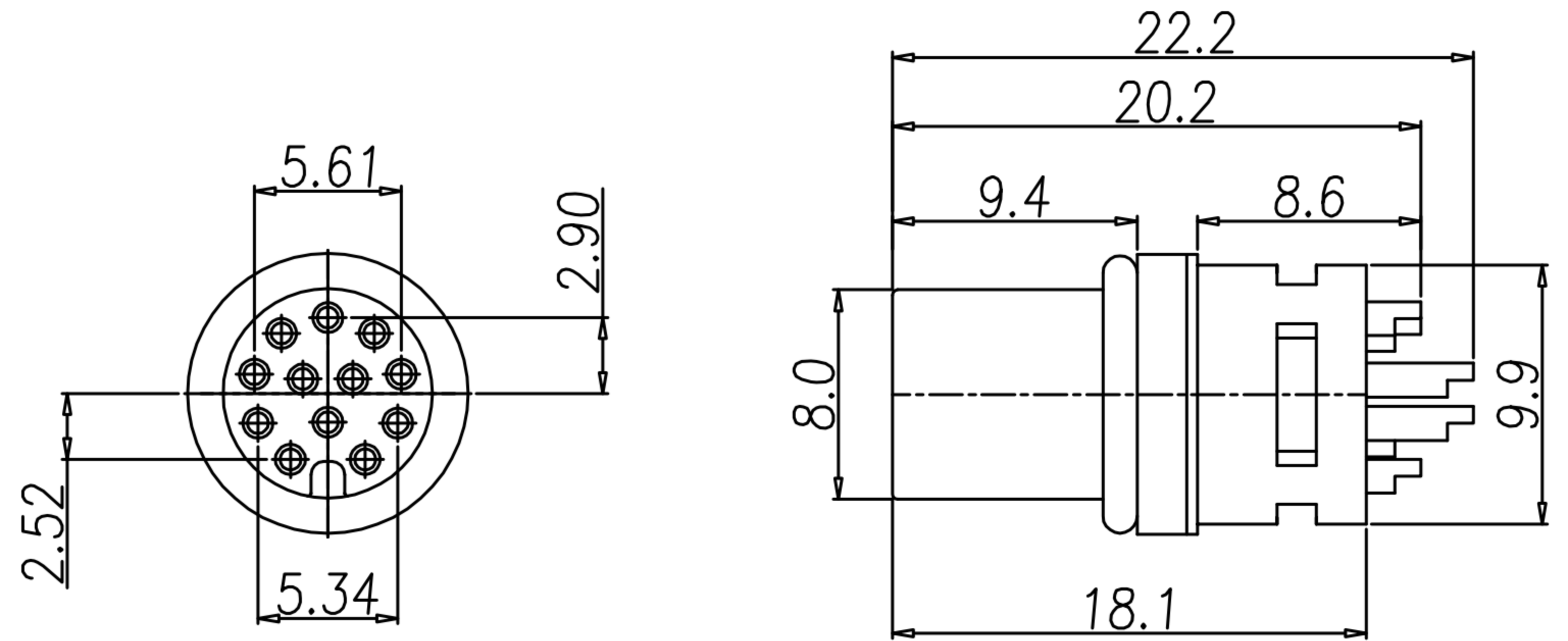

- MATERIAL :
 - 1-1. HOUSING : NYLON 66 UL94V-0 ; COLOR : SEE TABLE A
 - 1-2. CONTACT : BRASS
 - 1-3. NUT : BRASS
 - 1-4. O-RING : EDPM
 - 1-5. SHELL : BRASS
- FINISH :
 - 2-1. CONTACT : 10 MICRO INCHES MIN. GOLD PLATED
UNDER PLATE : NICKEL
 - 2-2. NUT : NICKEL PLATED
 - 2-3. SHELL : BRIGHT TIN
- ELECTRICAL SPECIFICATION :
 - 3-1. Rated current : 1.5A
 - 3-2. Rated Voltage : 30V
 - 3-3. Water proof: IP67/IP68
- Environmental :
 - 4-1. Operation Temperature : -40℃~105℃

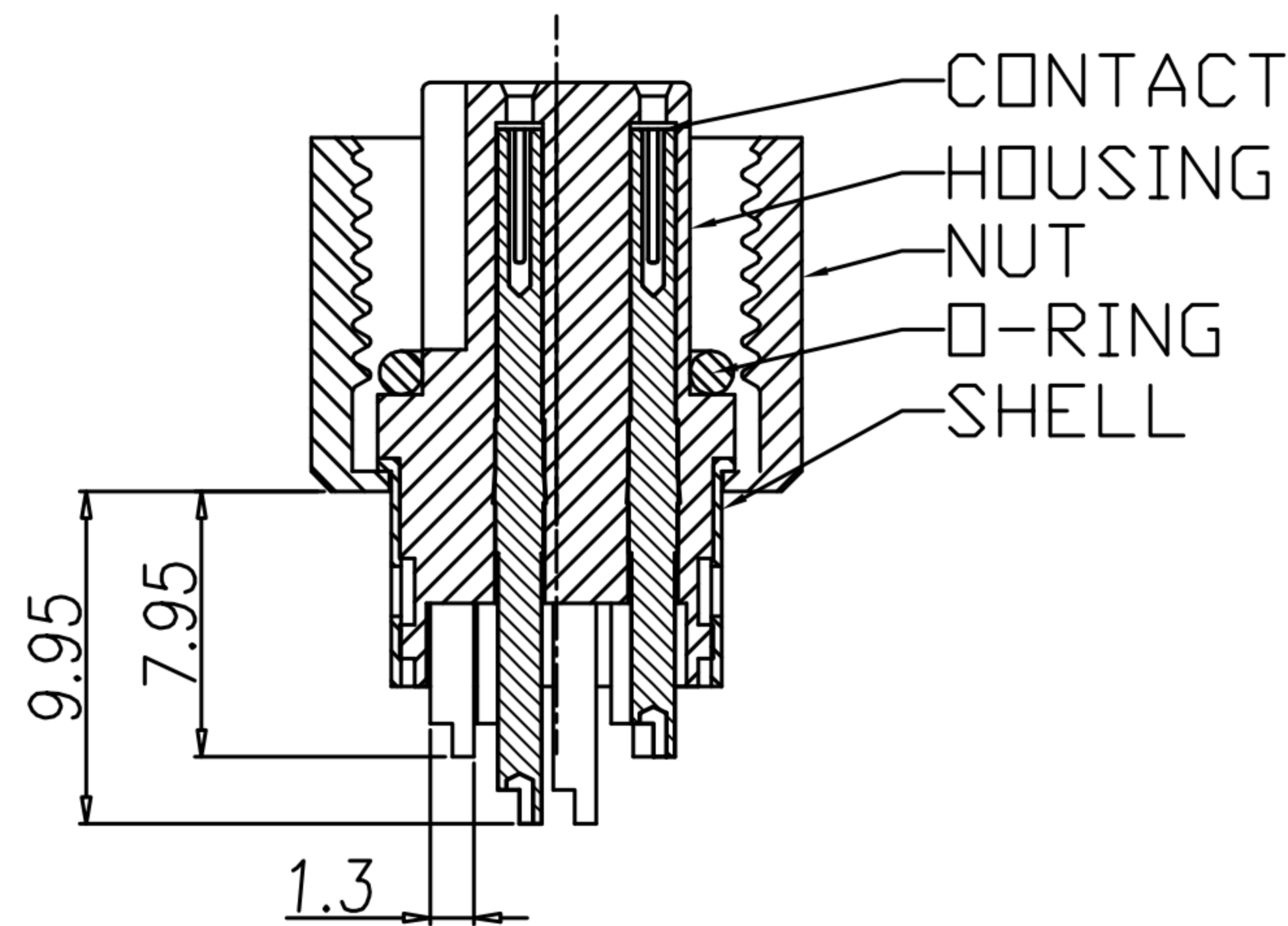
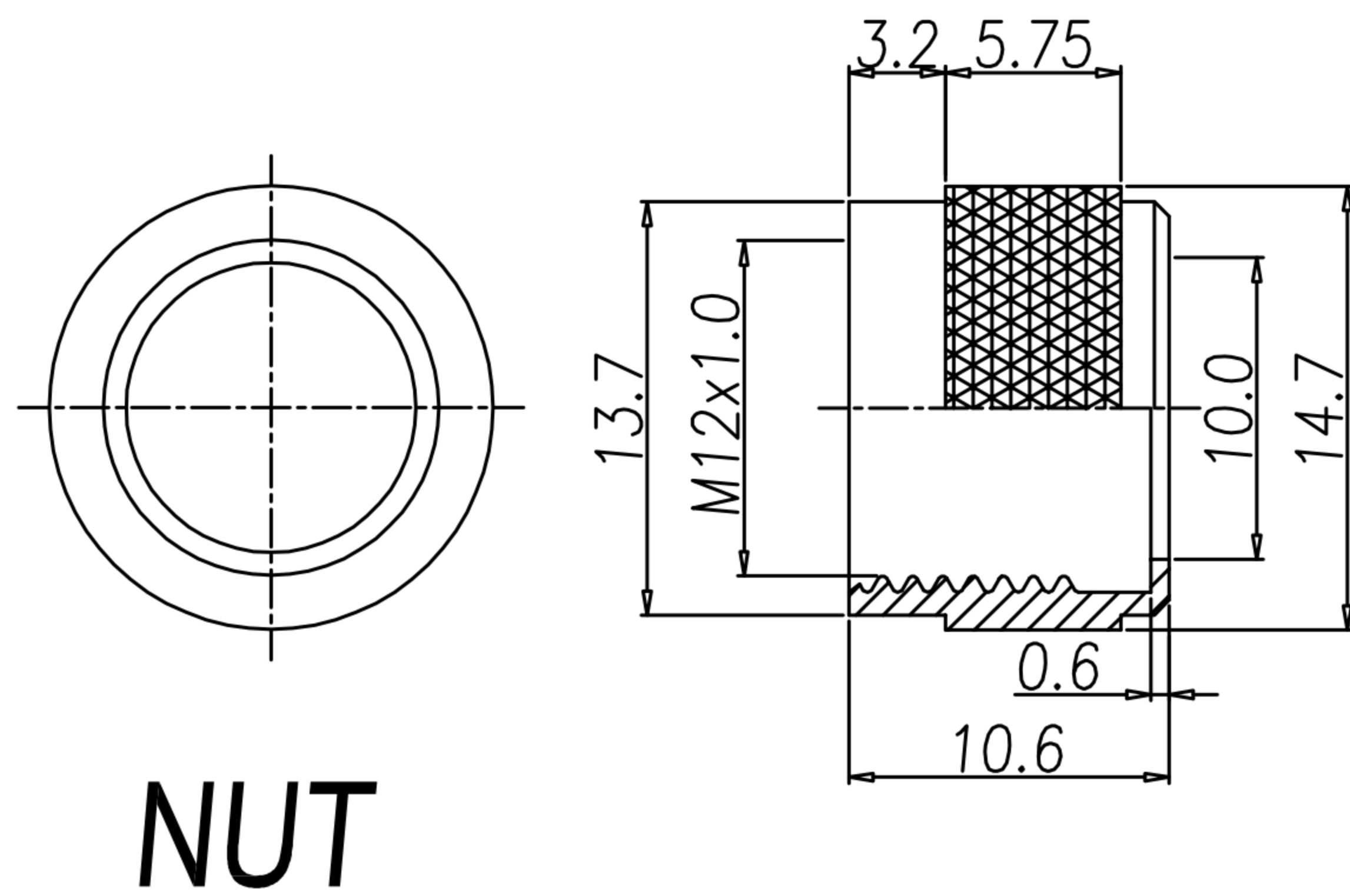

TABLE A

12PIN	10PIN
WP-12F2-16-11 WP-12F2-13-11	WP-10F2-19-11
WP-10F2-19-11	黑色/BLACK
WP-12F2-13-11	黑色/BLACK
WP-12F2-16-11	本色/Natural
PART No.	COLOR

DRAWN	Ku Chou	APP'D	Fido Weng	UNIT	mm	TOLERANCE			广东科斯达电子科技有限公司 GUANG DONG KE SI DA ELECTRONIC TECHNOLOGY CO., LTD.	TITLE	WP M12 (F) 屏線式螺母壓花 (接地部減)			SHEET	VERSION B
CHK'D	Emily Suen			SCALE	1:1					PART NO.	SEE TABLE A	DWG NO.	QC7430		