

CUSTOMER DRAWING

REV.	DESCRIPTION	APPROVED BY	DATE	ECN NO.
△A	RELEASE	LED	21/12/22'	
△B				
△C				

步驟一:

1. 將成品一一放入包裝盤內,依同一方向置入.
2. 包裝方式,如圖所示.
3. 一個包裝盤100pcs.(前後各留約十格)

步驟二:

1. 一個紙箱可以裝10個包裝盤.
2. 每盤100pcs,每箱1000pcs.
3. 將包裝盤放入防水袋中,包裝完後再封箱.

步驟三:

1. 用膠帶將紙箱封實.

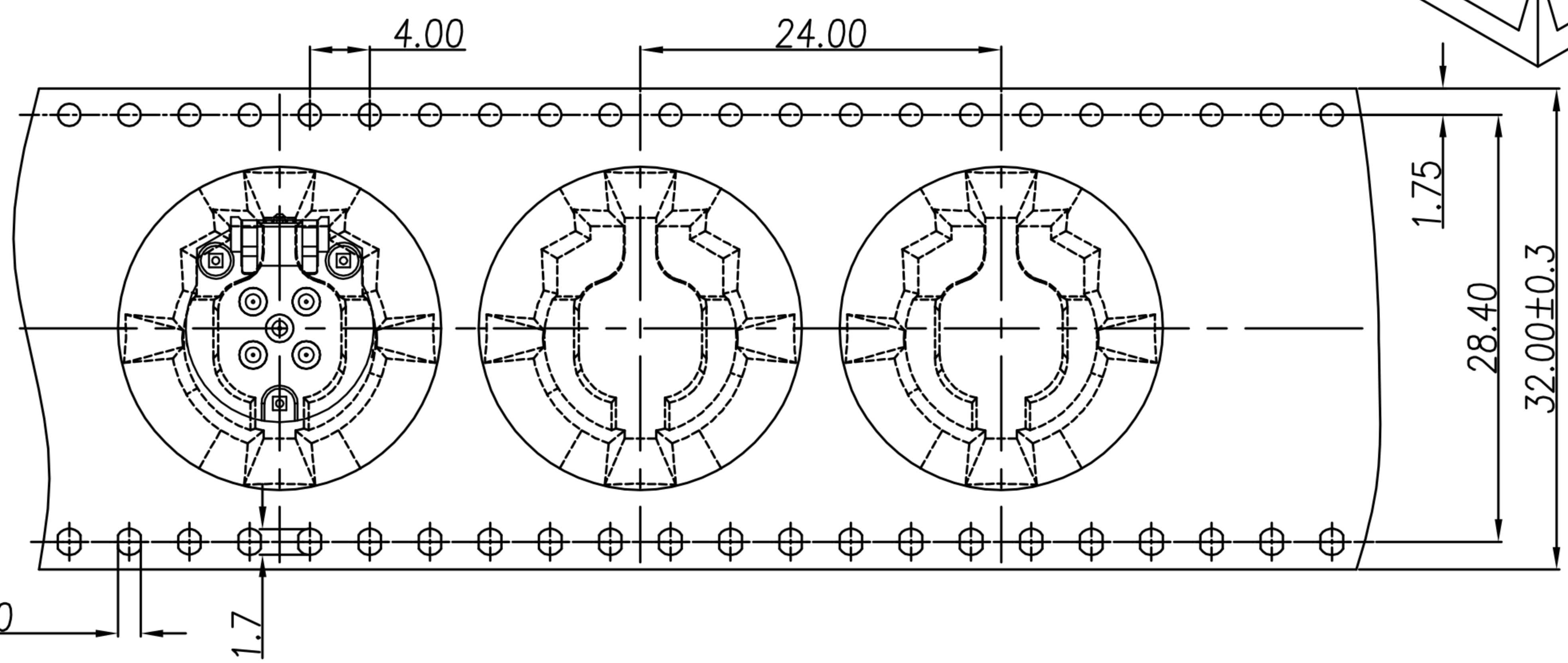
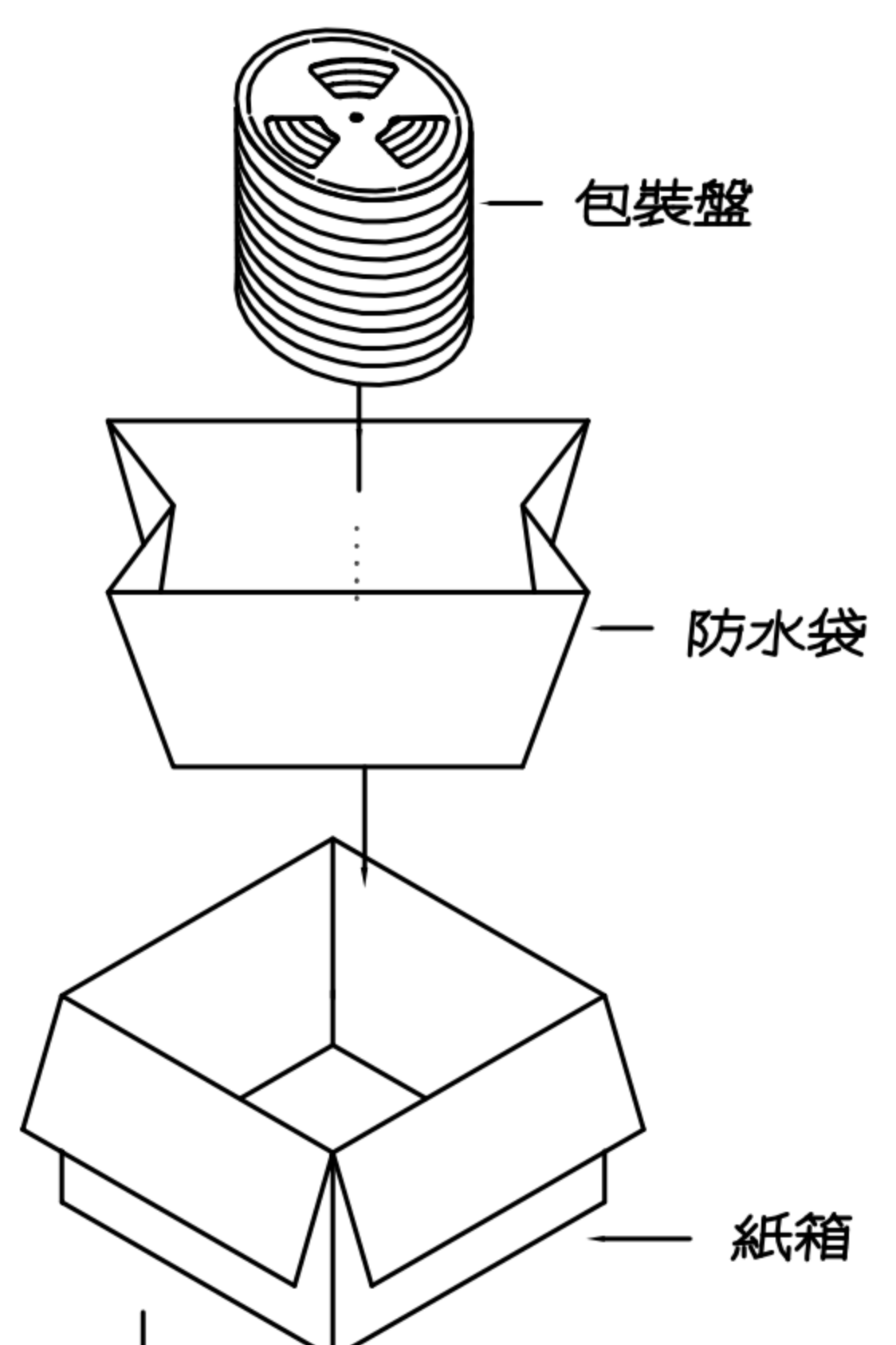
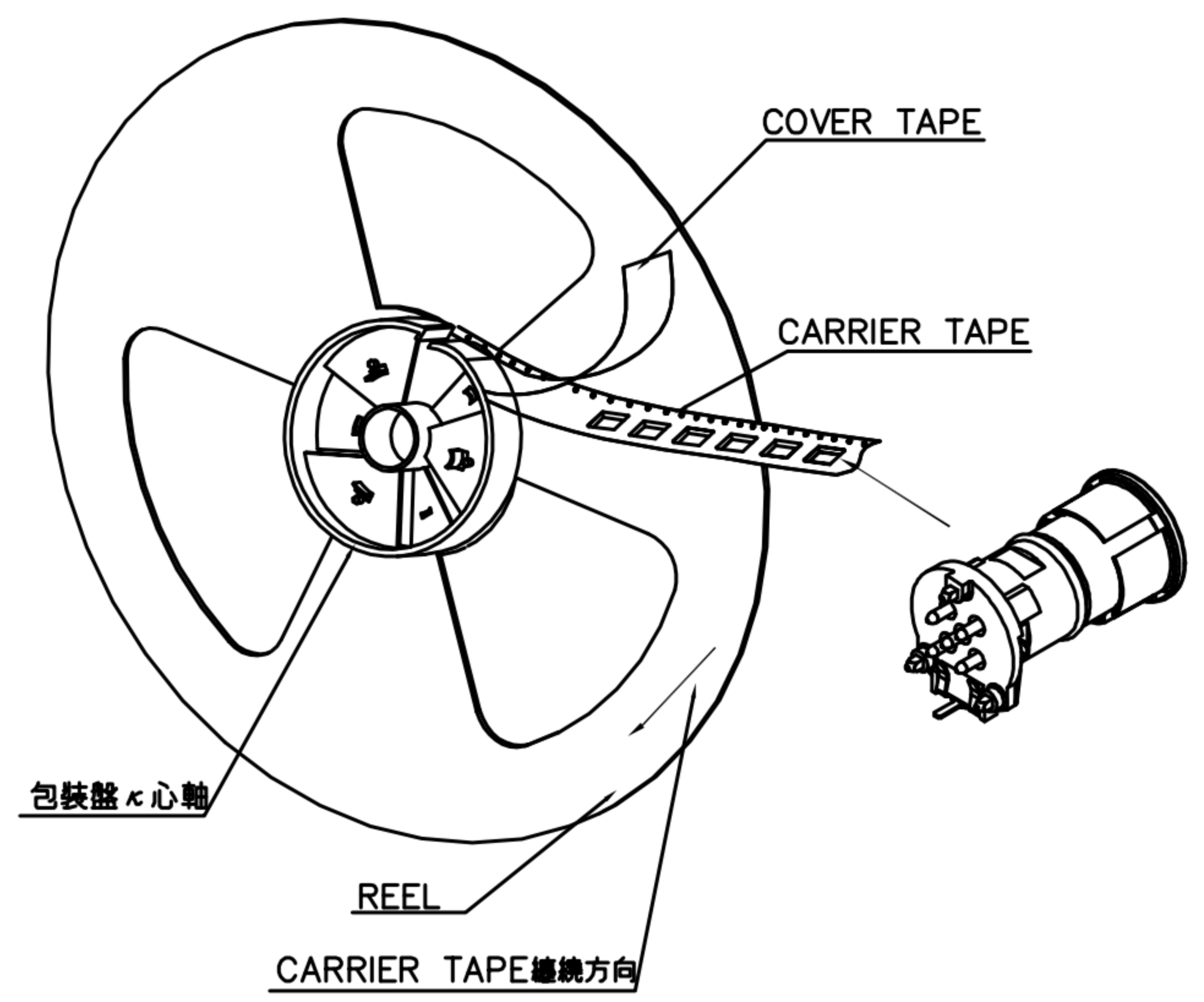
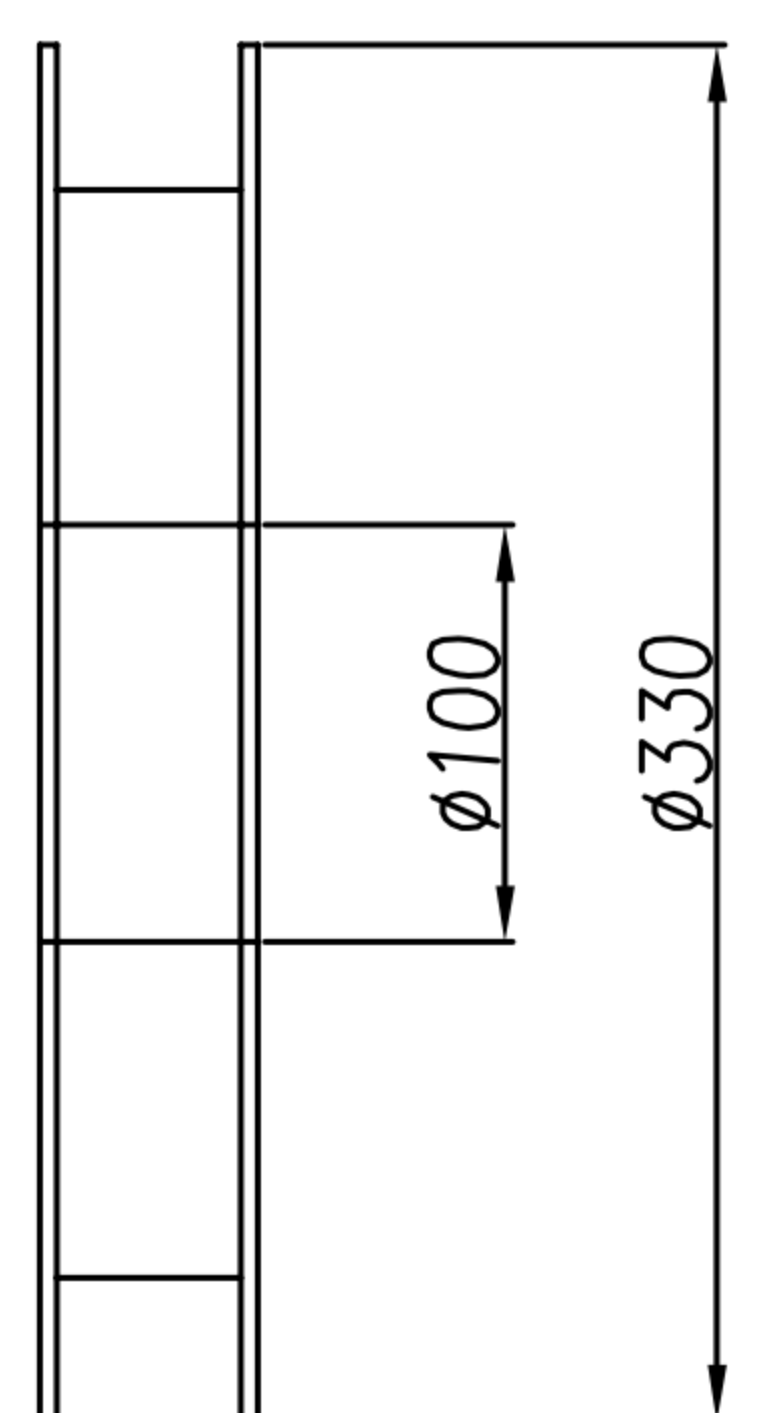

NOTE:

1. 料帶尺寸符合(EIA-481-D)規範要求.
2. 若有未裝滿之零數箱,必須以緩衝材塞滿.
3. 在搬運過程中要輕拿輕放.
4. 載運輸中不可堆放過多,不可有重壓現象.
5. 上帶在貼下帶時必須平整.

DRAWN	LED	APP'D	Ku Chou	UNIT	mm	TOLERANCE		广东科斯达电子科技有限公司 GUANG DONG KE SI DA ELECTRONIC TECHNOLOGY CO., LTD.	TITLE	WP M12 A-CODING (F) Two-piece (Straight shielded THR)			SHEET	2
CHK'D	Ku Chou			SCALE	1:1	.x ±0.20 .xx ±0.10 .xxx ±0.05 .xxxx ±0.03 ANGULA ±1°			PART NO.	SEE TABLE A	DWG NO.	QC10596	VERSION	A

CUSTOMER DRAWING

REV.	DESCRIPTION	APPROVED BY	DATE	ECN NO.
A	RELEASE	LED	12/12/22'	
B				
C				

TABLE A

WP-02F4-01-11	WP-03F4-01-11
WP-04F4-01-11	WP-05F4-03-11

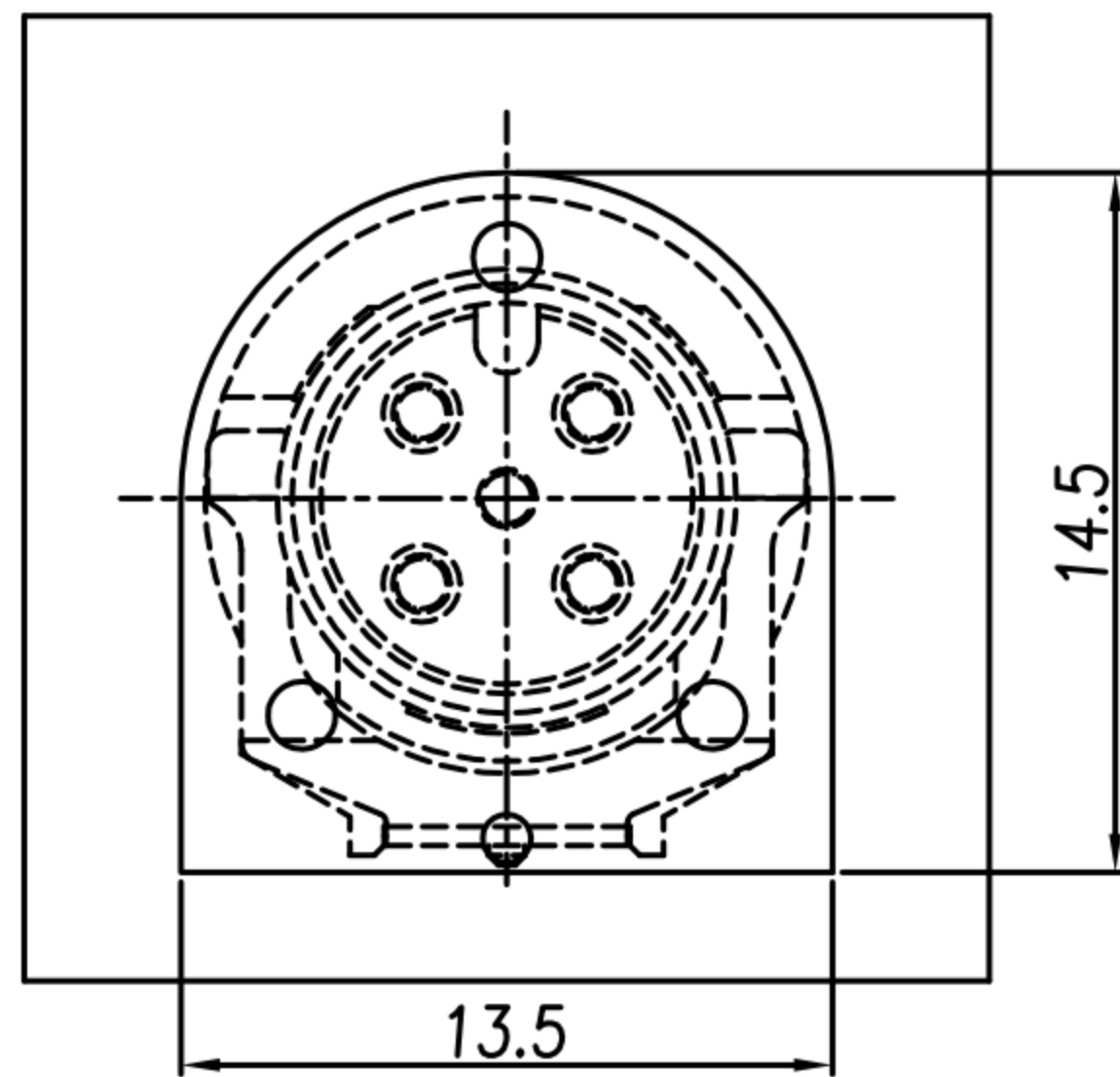
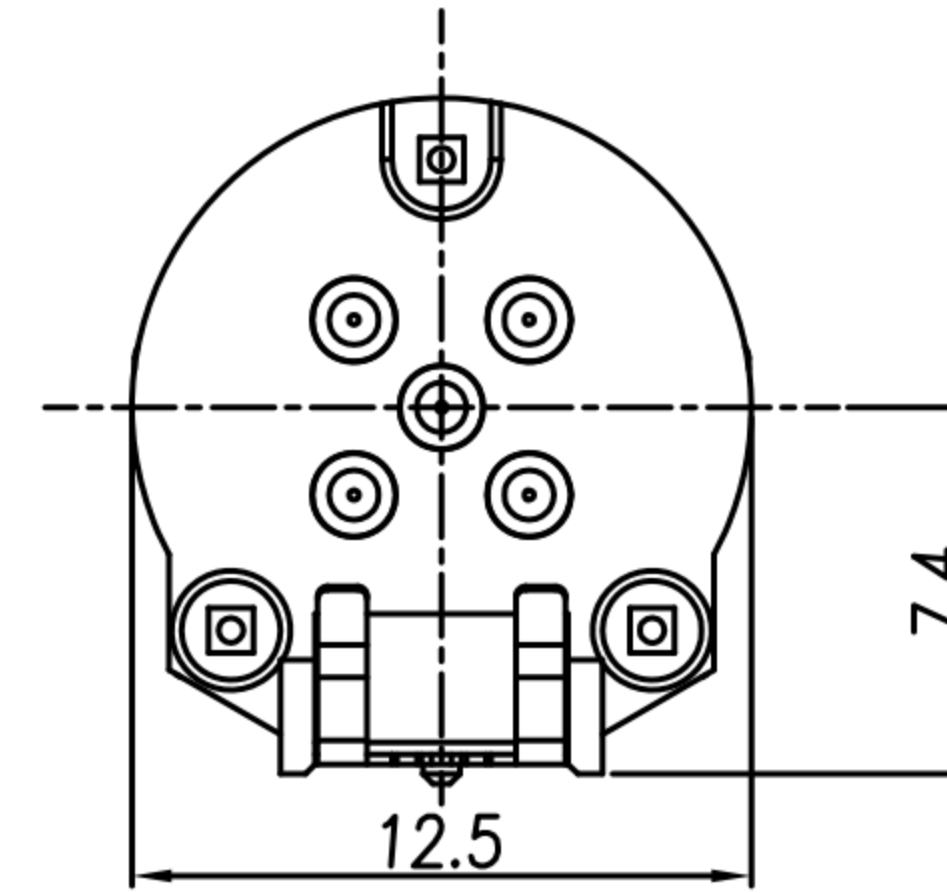
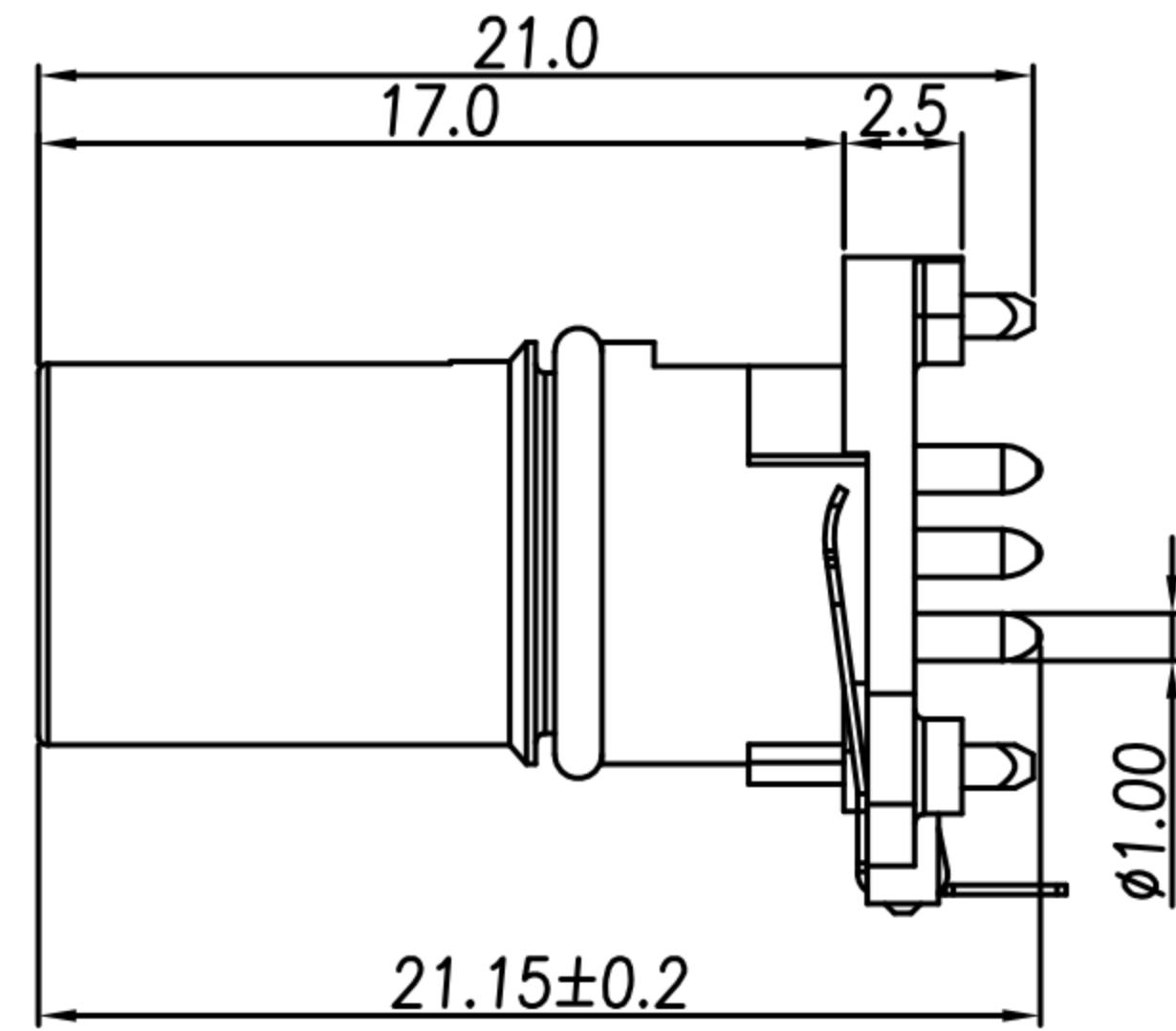
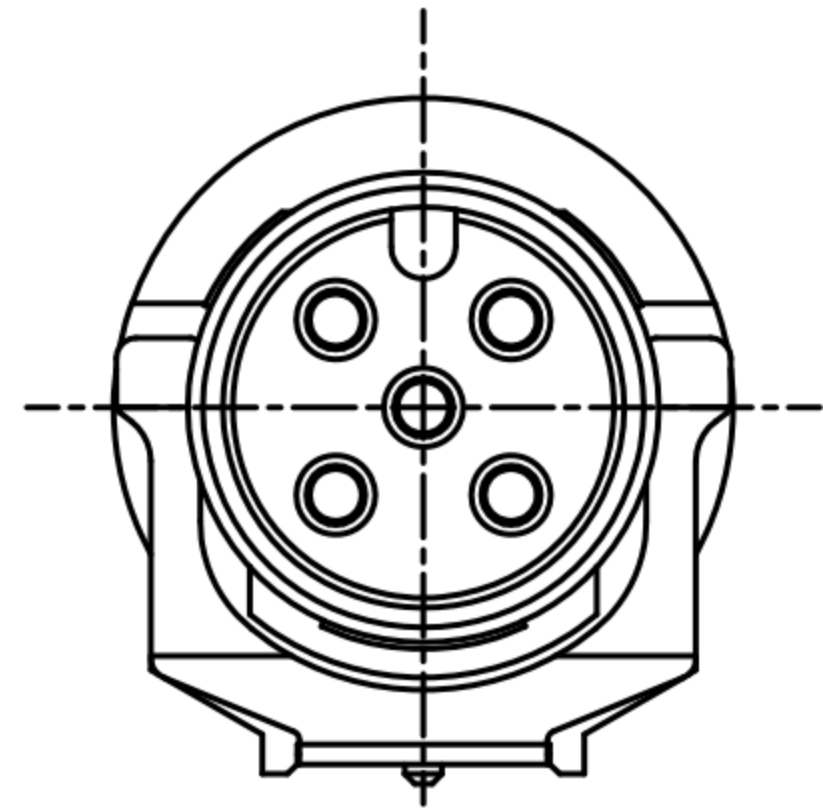

Component side (front view)
Recommended keepout area on the circuit board

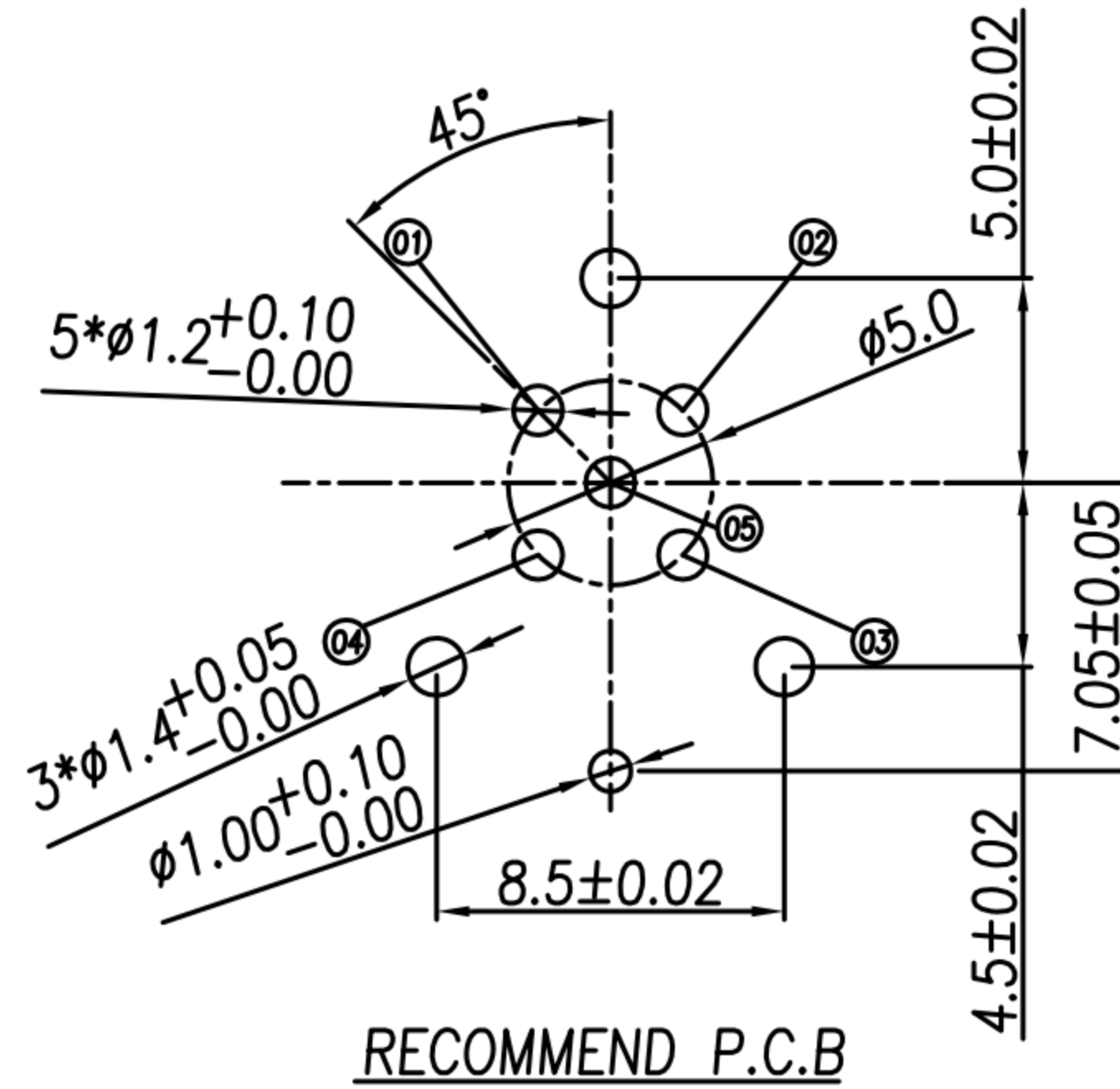

RECOMMEND P.C.B

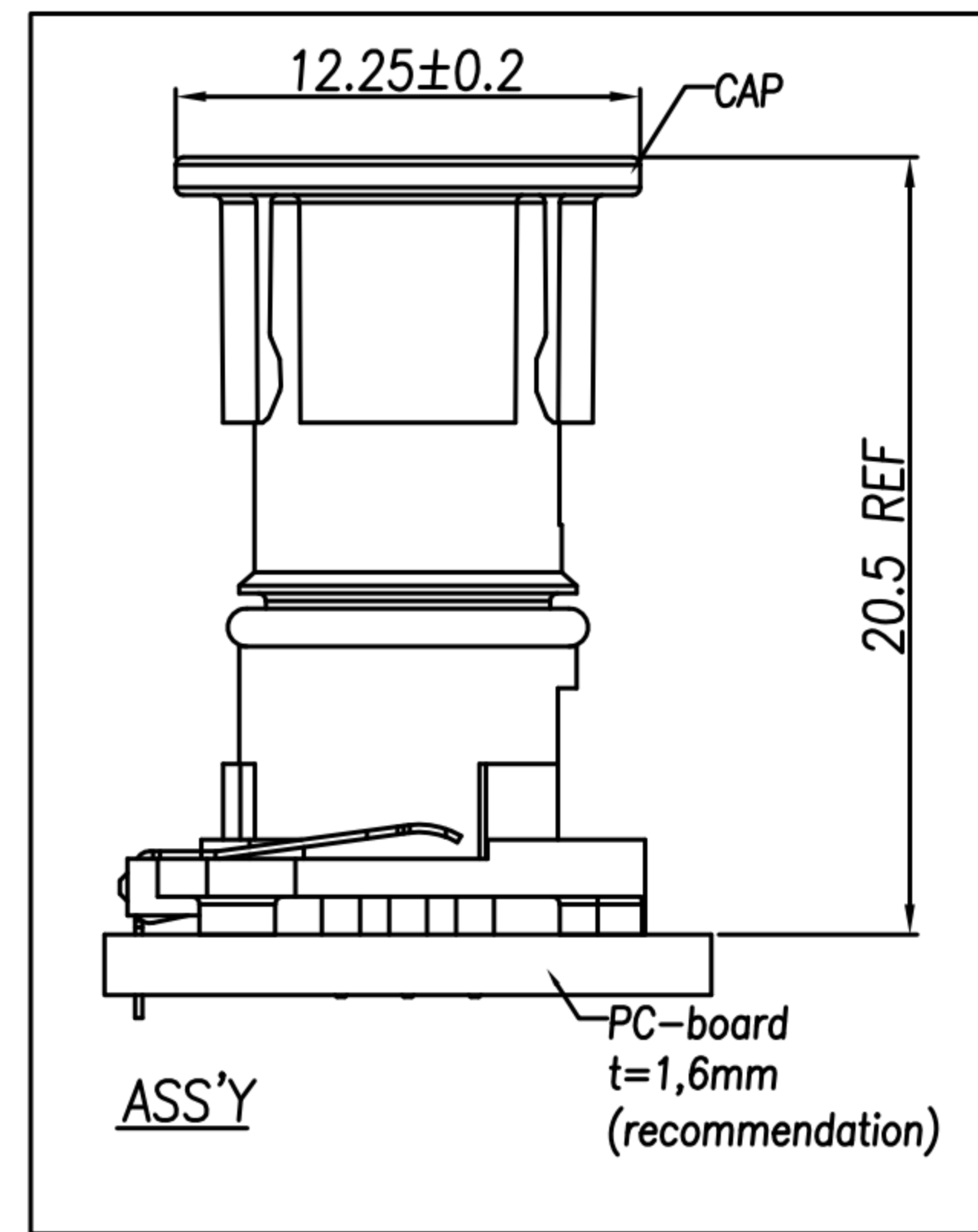

1. MATERIAL :

- 1-1. HOUSING : PA9T
- 1-2. CONTACT : BRASS
- 1-3. O-RING : VITON
- 1-4. CAP : PA66
- 1-5. GROUND : PHOSPHOR BRONZE

2. FINISH :

- 2-1. CONTACT : GOLD FLASH PLATED.
- 2-2. GROUND : NICKEL PLATED.

3. ELECTRICAL SPECIFICATION :

- 3-1. Rated current : 4A
- 3-2. Rated Voltage : 2PIN~4PIN 250V ;5PIN 60V
- 3-3. Water proof : IP67 (in mated condition)

4. Environmental :

- 4-1. Operation Temperature : -25℃~85℃

DRAWN	LED	APP'D	Ku Chou	UNIT	mm	TOLERANCE		广东科斯达电子科技有限公司 GUANG DONG KE SI DA ELECTRONIC TECHNOLOGY CO., LTD.	TITLE	WP M12 A-CODING (F) Two-piece (Straight shielded THR)			SHEET
CHK'D	Ku Chou			SCALE	1:1	.x ±0.20 .xx ±0.10 .xxx ±0.05 .xxxx ±0.03 ANGULAR ±1°			PART NO.	SEE TABLE A	DWG NO.	QC10596	VERSION