

CUSTOMER DRAWING

REV.	DESCRIPTION	APPROVED BY	DATE	ECN NO.
△B	CHANGE CLAMP RING MATERIAL	Ku Chou	31/10/18'	
△C	ADD 6PIN P/N	Ku Chou	06/03/19'	
△D	ADD 6PIN P/N	Ku Chou	24/05/19'	

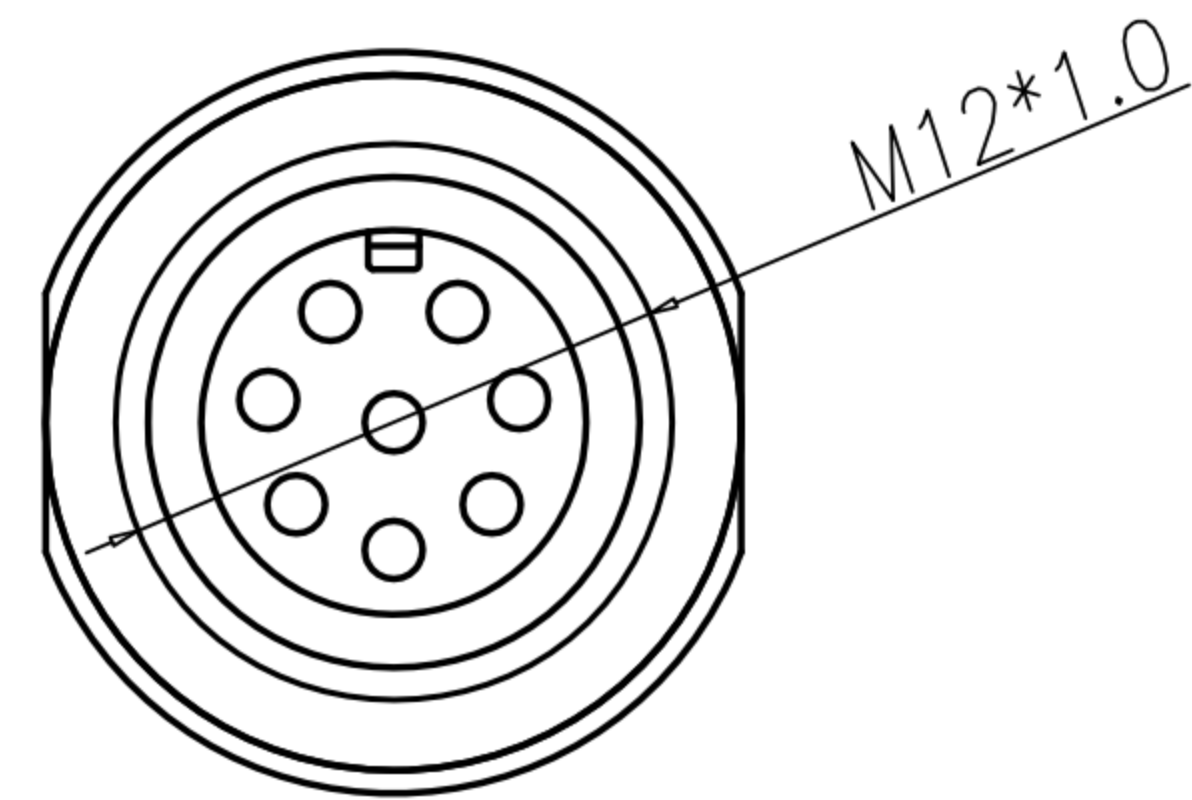
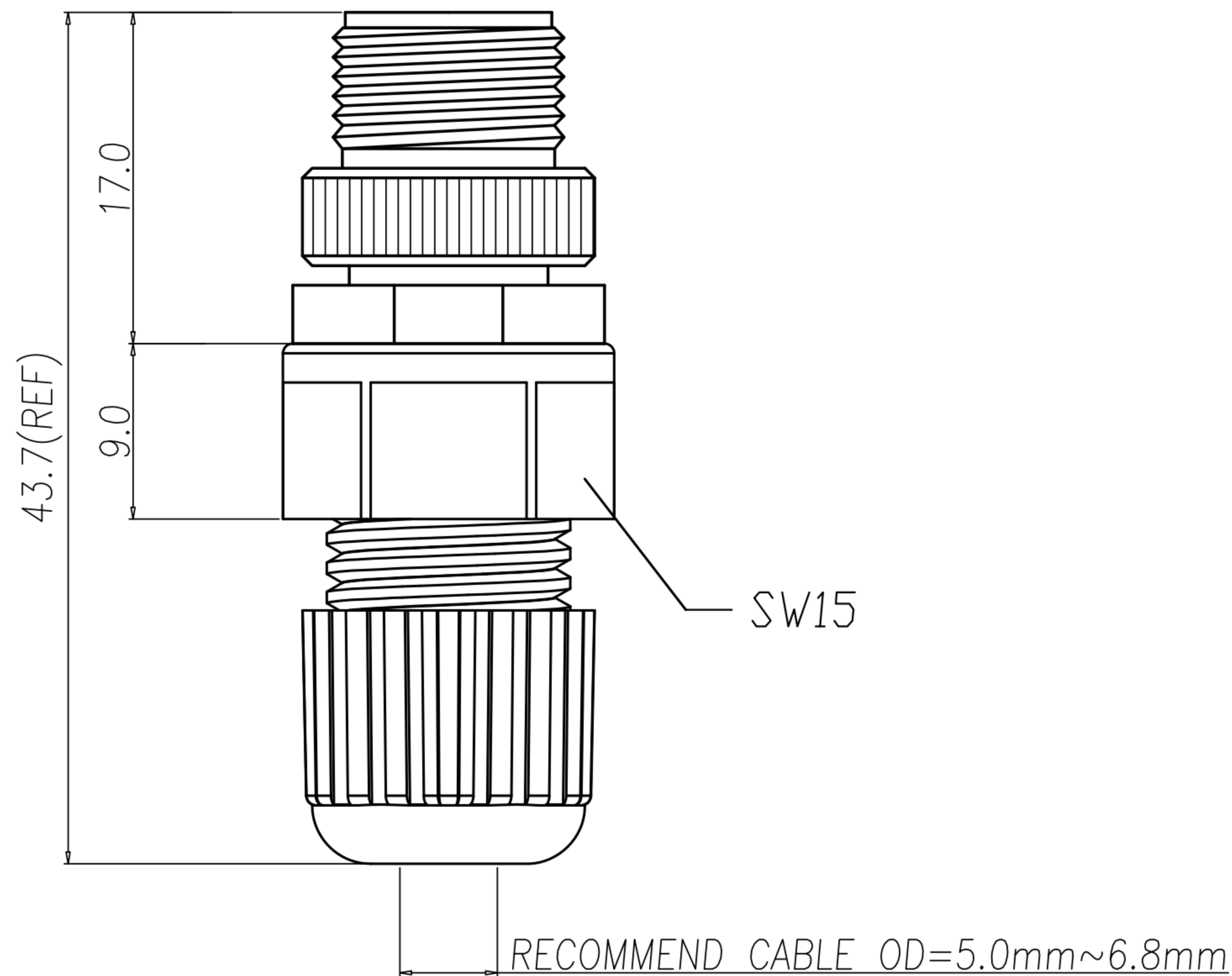

TABLE A

WP-08M2-80-11	7P	WP-06M2-68-11	WP-06M2-67-11



1. MATERIAL :

- 1-1. HOUSING : PBT UL94V-0 ; COLOR : BLACK.
- 1-2. CONTACT : BRASS
- 1-3. SHELL : BRASS
- 1-4. NUT : ALUMINUM ALLOY
- 1-5. GASKET : SILICONE
- 1-6. CLAMP RING : PA66 △B
- 1-7. SEAL : SILICONE
- 1-8. SEALING NUT : PA66

2. FINISH :

- 2-1. CONTACT : GOLD FLASH PLATED.
- 2-2. NUT : NICKEL PLATED.
- 2-3. SHELL : NICKEL PLATED.

3. ELECTRICAL SPECIFICATION :

- 3-1. Rated current : 2A
- 3-2. Rated voltage : 30V
- 3-3. Water proof : IP67

4. Environmental :

- 4-1. Operation Temperature : -40℃~105℃

DRAWN	Emily Suen	APP'D	Ku Chou	UNIT	mm	TOLERANCE			TITLE	M12 (M) A-coded Assembly type(塑膠本體)			SHEET	
CHK'D	Ku Chou			SCALE	1:1	.x ±0.20 .xx ±0.10 .xxx ±0.05 .xxxx ±0.03 ANGULA ±1°			PART NO.	SEE TABLE A	DWG NO.	QC8679	VERSION	