

CUSTOMER DRAWING

REV.	DESCRIPTION	APPROVED BY	DATE	ECN NO.
△A	RELEASE	Fido Weng	04/03/10'	
△B				
△C				

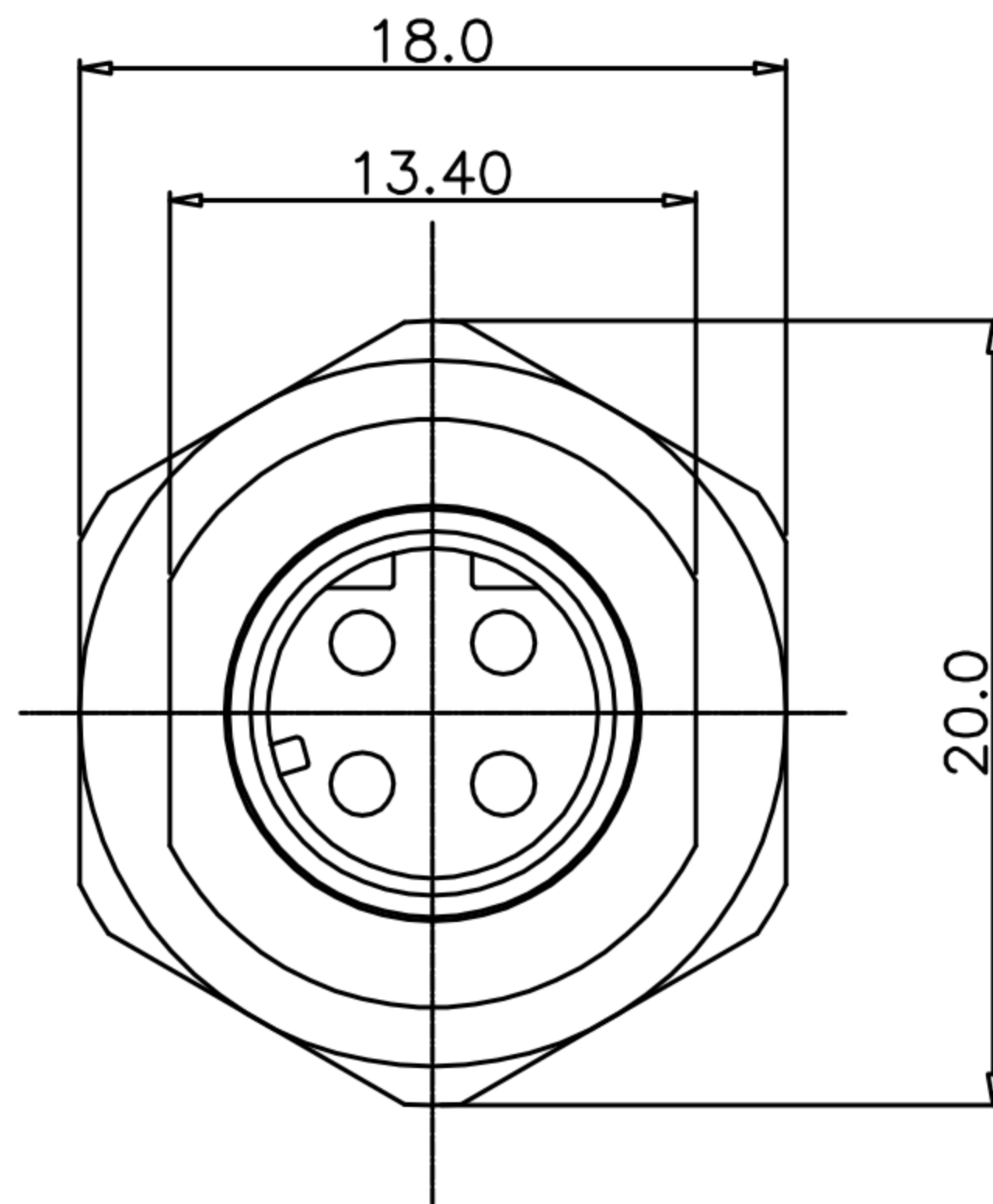
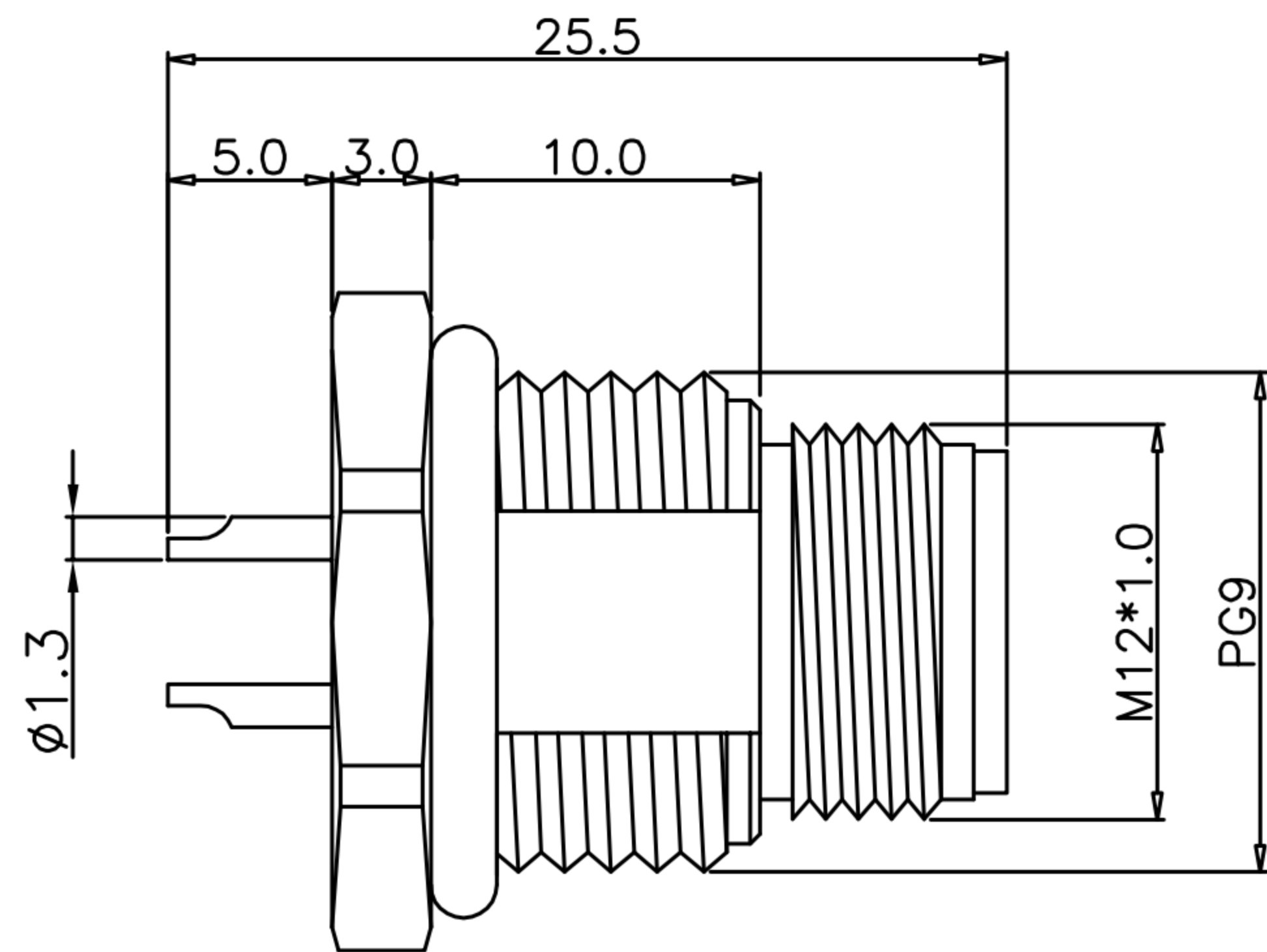
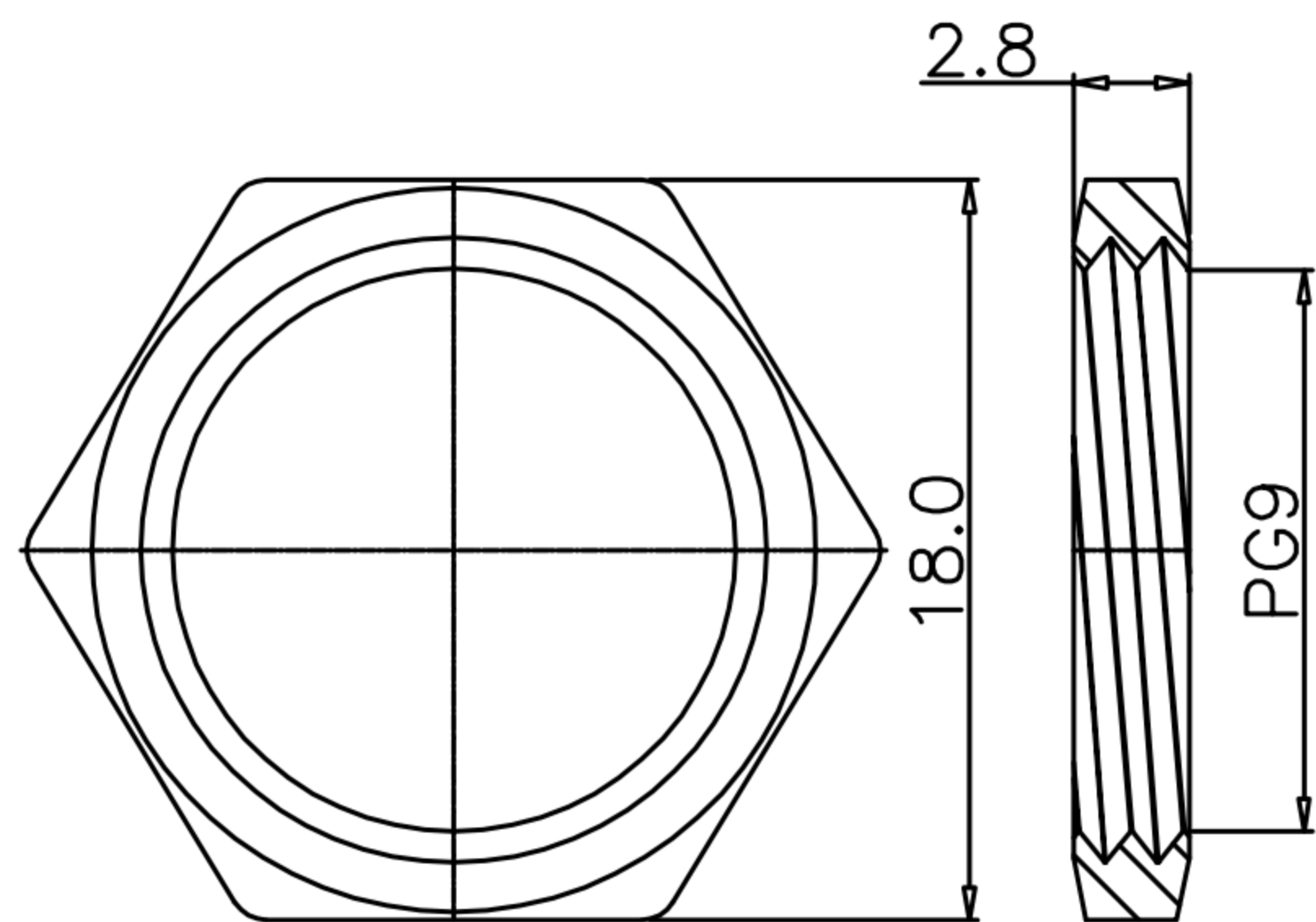
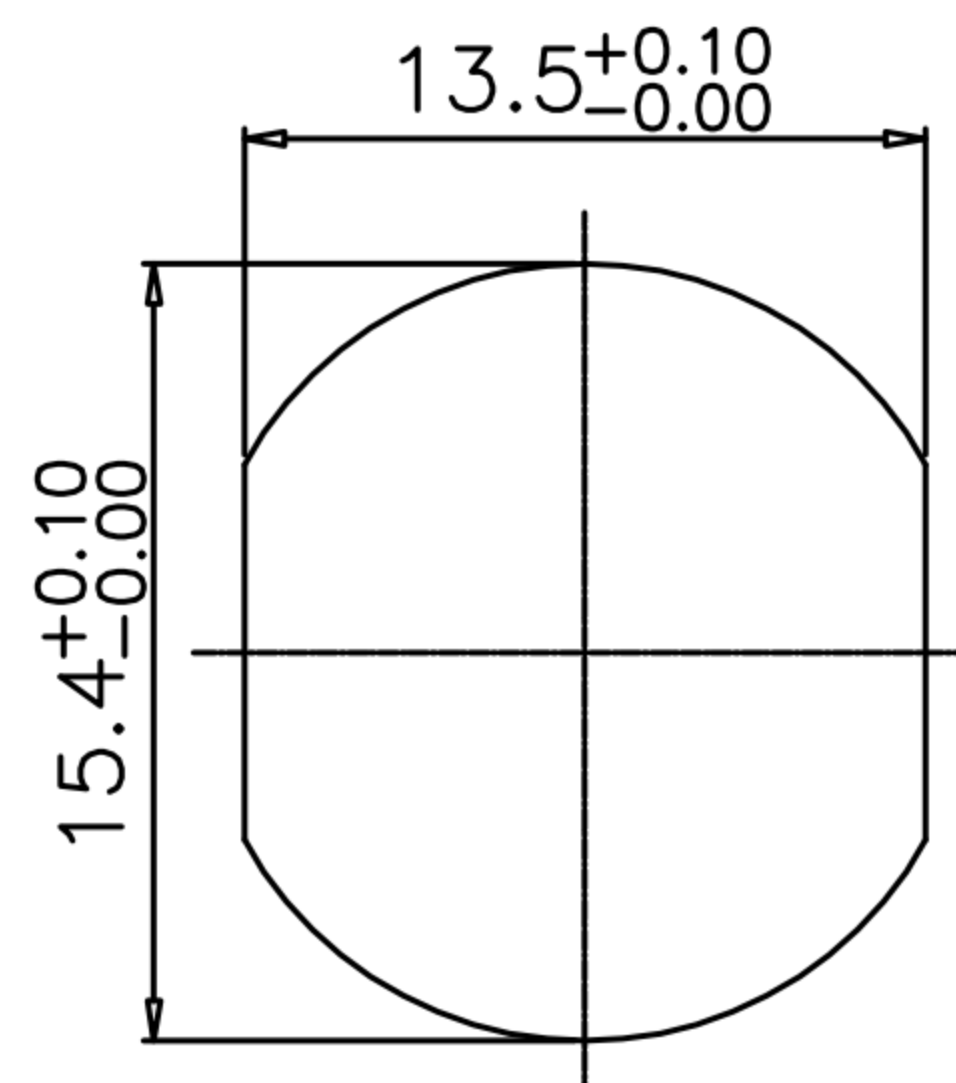

TABLE A

4PIN		5PIN	
WP-04M2-222-11	WP-04M2-135-11	WP-04M2-134-11	WP-05M2-211-11
WP-05M2-211-11	BRASS	NICKEL PLATED	GOLD 10u"
WP-04M2-222-11	STAINLESS STEEL 316	PASSIVATION	GOLD 10u"
WP-04M2-135-11	BRASS	NICKEL PLATED	GOLD 10u"
WP-04M2-134-11	BRASS	NICKEL PLATED	GOLD FLASH
PART NO	MATERIAL(SHELL&NUT)	FINISH(SHELL&NUT)	FINISH(CONTACT)



NUT



RECOMMEND PANEL CUT-OUT

- MATERIAL :
 - 1-1. HOUSING : PBT UL94V-0 ; COLOR : BLACK
 - 1-2. CONTACT : BRASS
 - 1-3. NUT : SEE TABLE A
 - 1-4. SHELL : SEE TABLE A
 - 1-5. O-RING : EPDM ; COLOR : BLACK
- FINISH :
 - 2-1. CONTACT : SEE TABLE A
UNDER PLATE : NICKEL
 - 2-2. NUT : SEE TABLE A
 - 2-3. SHELL : SEE TABLE A
- ELECTRICAL SPECIFICATION :
 - 3-1. Rated current : 4A
 - 3-2. Rated voltage : 4PIN 250V ; 5PIN 60V
 - 3-3. Water proof : IP67
- Environmental :
 - 4-1. Operation Temperature : -40℃~85℃

DRAWN	Ku Chou	APPEND	Fido Weng	UNIT	mm	TOLERANCE		广东科斯达电子科技有限公司 GUANG DONG KE SI DA ELECTRONIC TECHNOLOGY CO., LTD.	TITLE	防水頭 M12 D-Code (M) 前鎖 PG9 焊線式			SHEET	1
CHKED	Emily Suen			SCALE	1:1	.x ±0.20 .xx ±0.10 .xxx ±0.05 .xxxx ±0.03 ANGULA ±1°			PART NO.	SEE TABLE A	DWG NO.	QC7521	VERSION	A