

CUSTOMER DRAWING

REV.	DESCRIPTION	APPROVED BY	DATE	ECN NO.
△A	RELEASE	Fido Weng		
△B				
△C				

ASSEMBLY INSTRUCTION

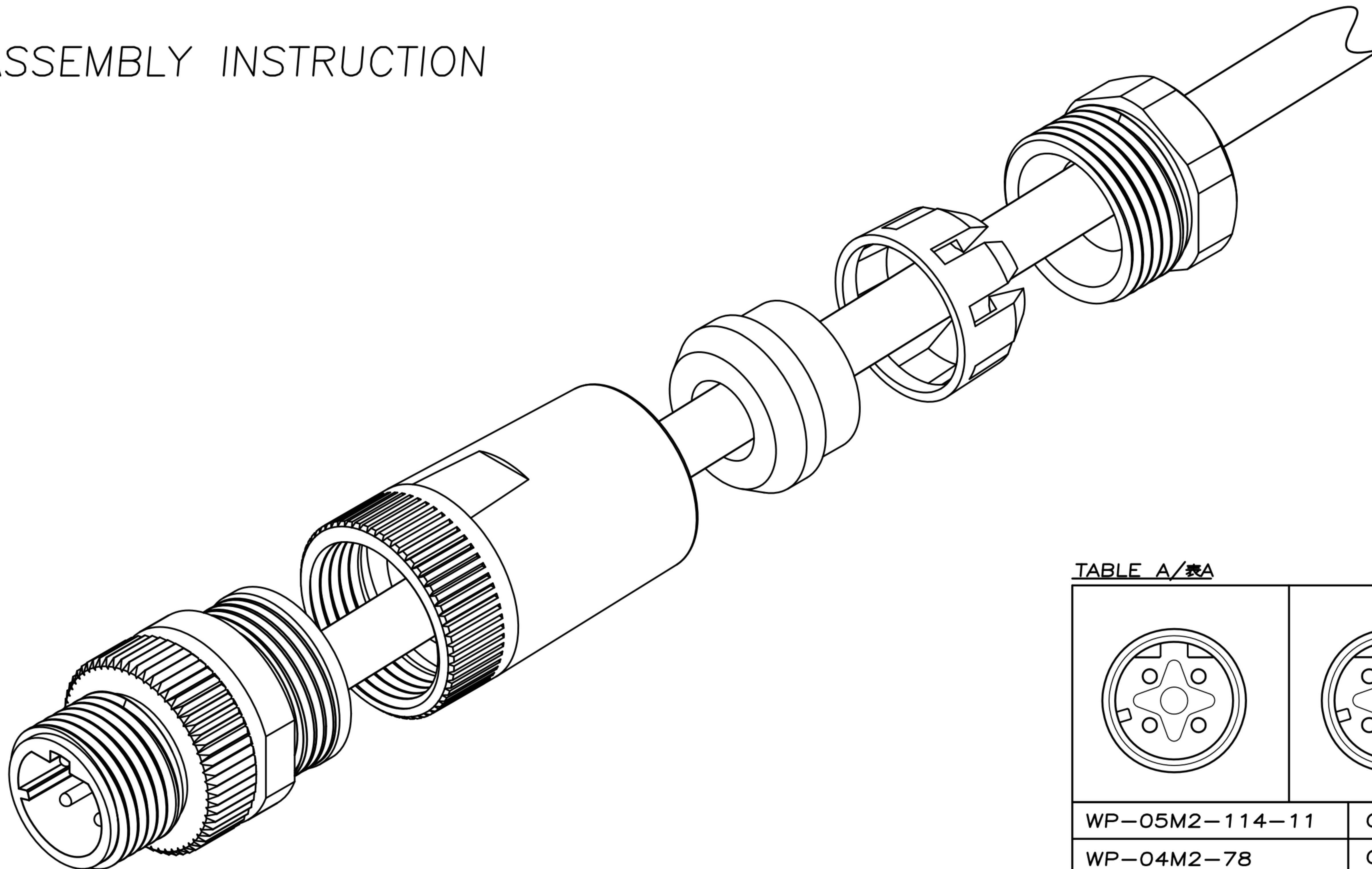

TABLE A/表A

WP-05M2-114-11	GOLD FLASH
WP-04M2-78	GOLD FLASH
WP-04M2-137-11	GOLD 10u"
PART NO	FINISH

DRAWN	Mark Kao	APP'D	Ku Chou	UNIT	mm	TOLERANCE			TITLE	M12 4PIN(M) D-coded Assembly type			SHEET	2
CHK'D	Emily Suen			SCALE	1:1	.x ±0.20 .xx ±0.10 .xxx ±0.05 .xxxx ±0.03 ANGULA ±1°			PART NO.	SEE TABLE A	DWG NO.	QC5980	VERSION	A

广东科斯达电子科技有限公司  
GUANG DONG KE SI DA ELECTRONIC TECHNOLOGY CO., LTD.



CUSTOMER DRAWING

REV.	DESCRIPTION	APPROVED BY	DATE	ECN NO.
A	RELEASE	Fido Weng		
B				
C				

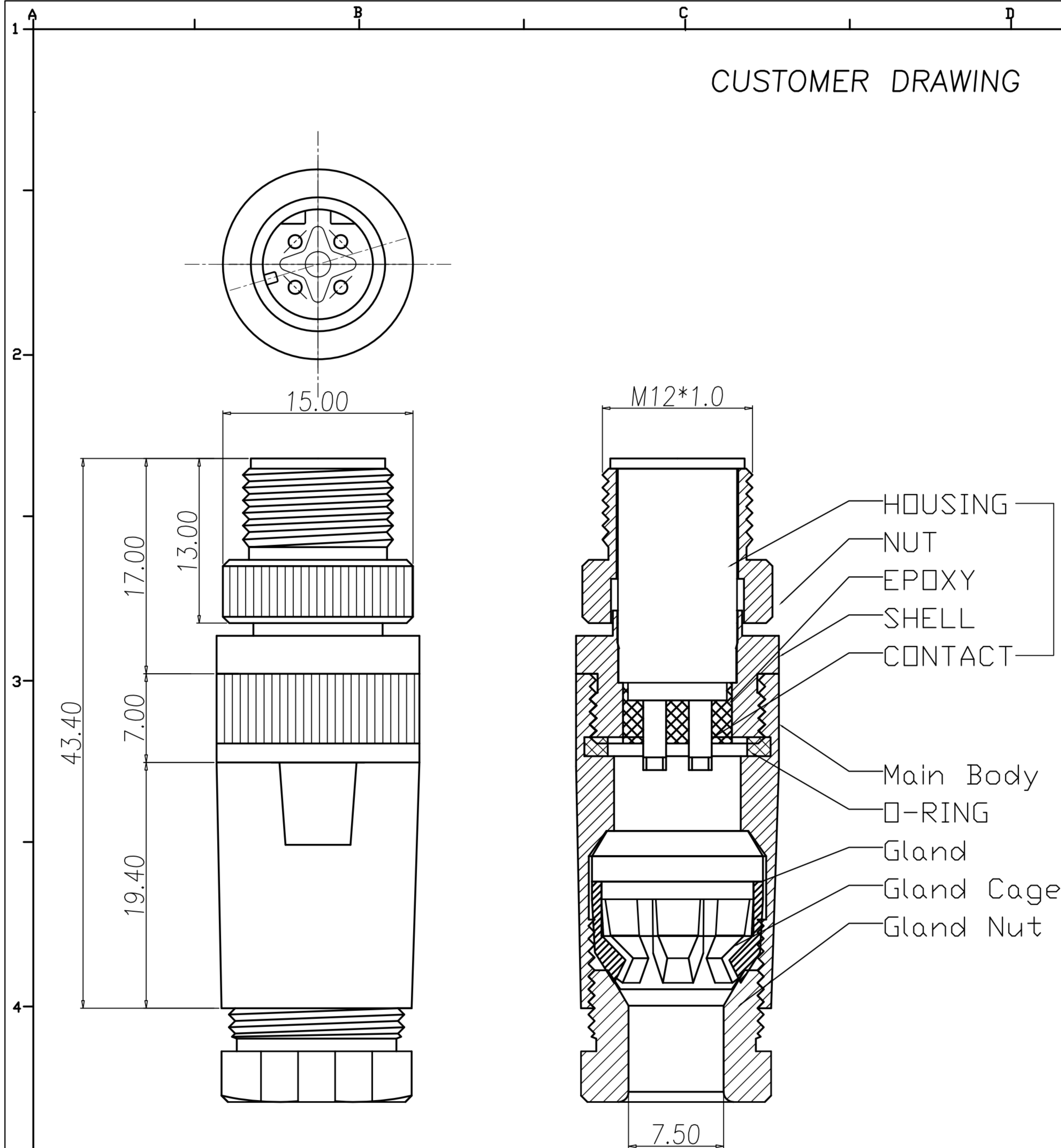

TABLE A/表A

WP-05M2-114-11	GOLD FLASH
WP-04M2-78	GOLD FLASH
WP-04M2-137-11	GOLD 10u"
PART NO	FINISH

- MATERIAL :
  - 1-1. NY-WP494 :
    - a. HOUSING : PBT UL94V-0 ; COLOR : BLACK.
    - b. CONTACT : BRASS
    - c. NUT : ALUMINUM ALLOY
    - d. SHELL : ALUMINUM ALLOY
  - 1-2. Main Body : ALUMINUM ALLOY
  - 1-3. Gland : SILICONE COLOR : BLACK.
  - 1-4. Gland Cage : POM ; COLOR : BLACK.
  - 1-5. Gland Nut : ALUMINUM ALLOY.
  - 1-6. O-Ring : SILICONE COLOR : BLACK.
- FINISH :
  - 2-1. NY-WPXXX :
    - a. CONTACT : SEE TABLE A  
UNDER PLATE : NICKEL.
    - b. NUT : SATIN Ni PLATED.
    - c. SHELL : SATIN Ni PLATED.
  - 2-2. Main Body : SATIN Ni PLATED.
  - 2-3. Gland Nut : SATIN Ni PLATED.
- ELECTRICAL SPECIFICATION :
  - 3-1. Rated current : 4A
  - 3-2. Rated Voltage : 4PIN 250V ; 5PIN 60V
  - 3-3. Water proof : IPX7
- Environmental :
  - 4-1. Operation Temperature : -20 ℃~85℃

DRAWN	Mark Kao	APP'D	Ku Chou	UNIT	mm	TOLERANCE		广东科斯达电子科技有限公司 GUANG DONG KE SI DA ELECTRONIC TECHNOLOGY CO., LTD.	TITLE	M12 4PIN(M) D-coded Assembly type			SHEET	1/2
CHK'D	Emily Suen			SCALE	1:1	.x ±0.20 .xx ±0.10 .xxx ±0.05 .xxxx ±0.03 ANGULA ±1°			PART NO.	SEE TABLE A	DWG NO.	QC5980	VERSION	A