

CUSTOMER DRAWING

REV.	DESCRIPTION	APPROVED BY	DATE	ECN NO.
△A	RELEASE	Fido Weng	10/01/11'	
△B				
△C				

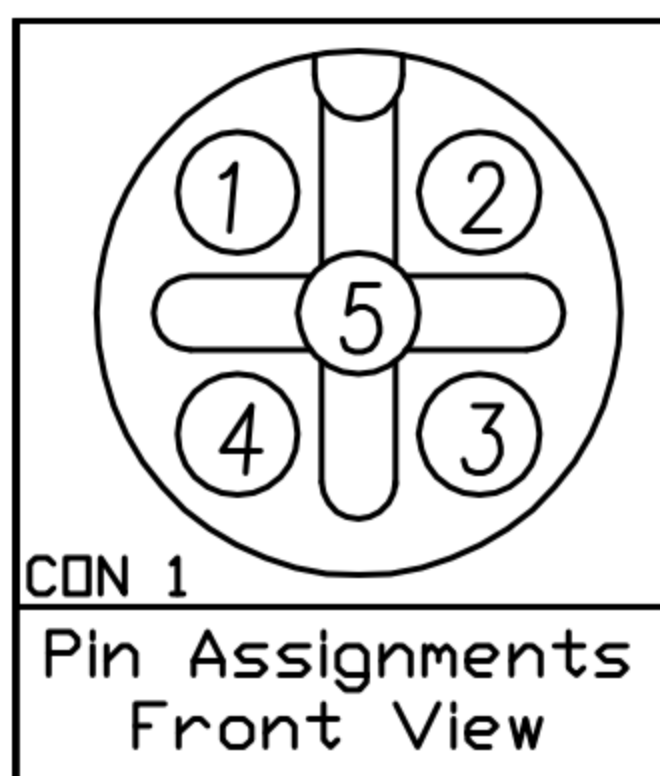
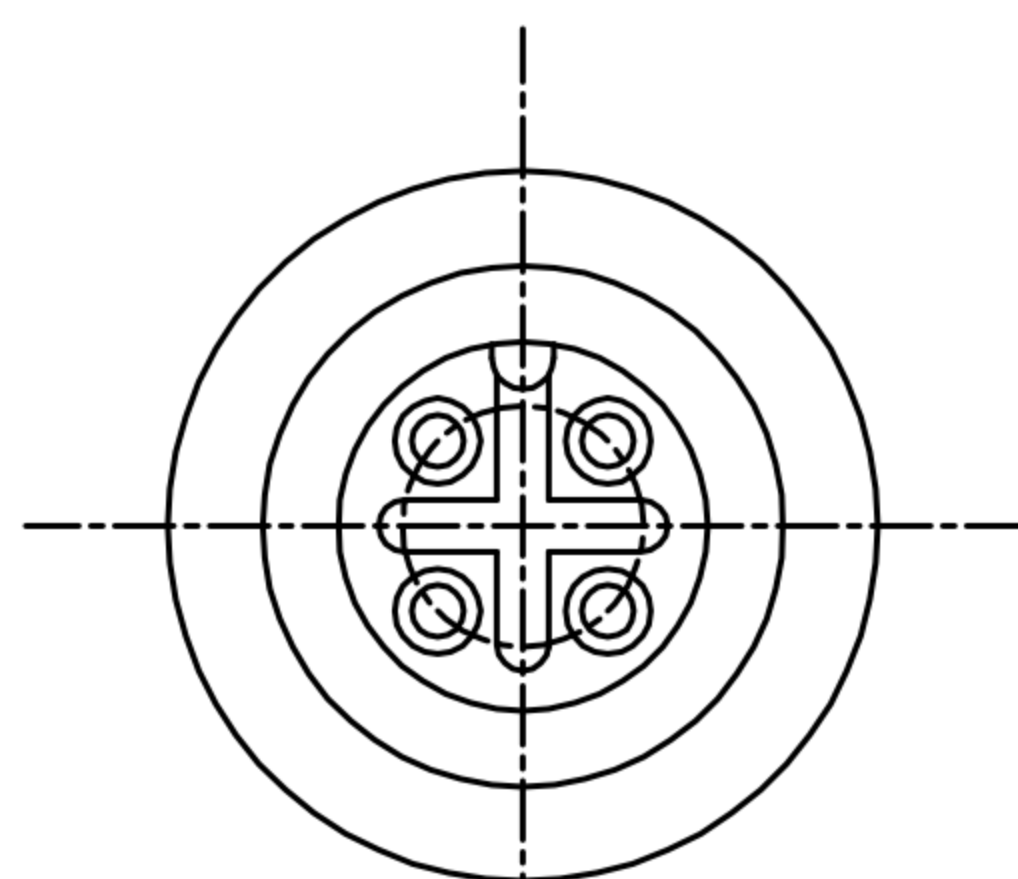
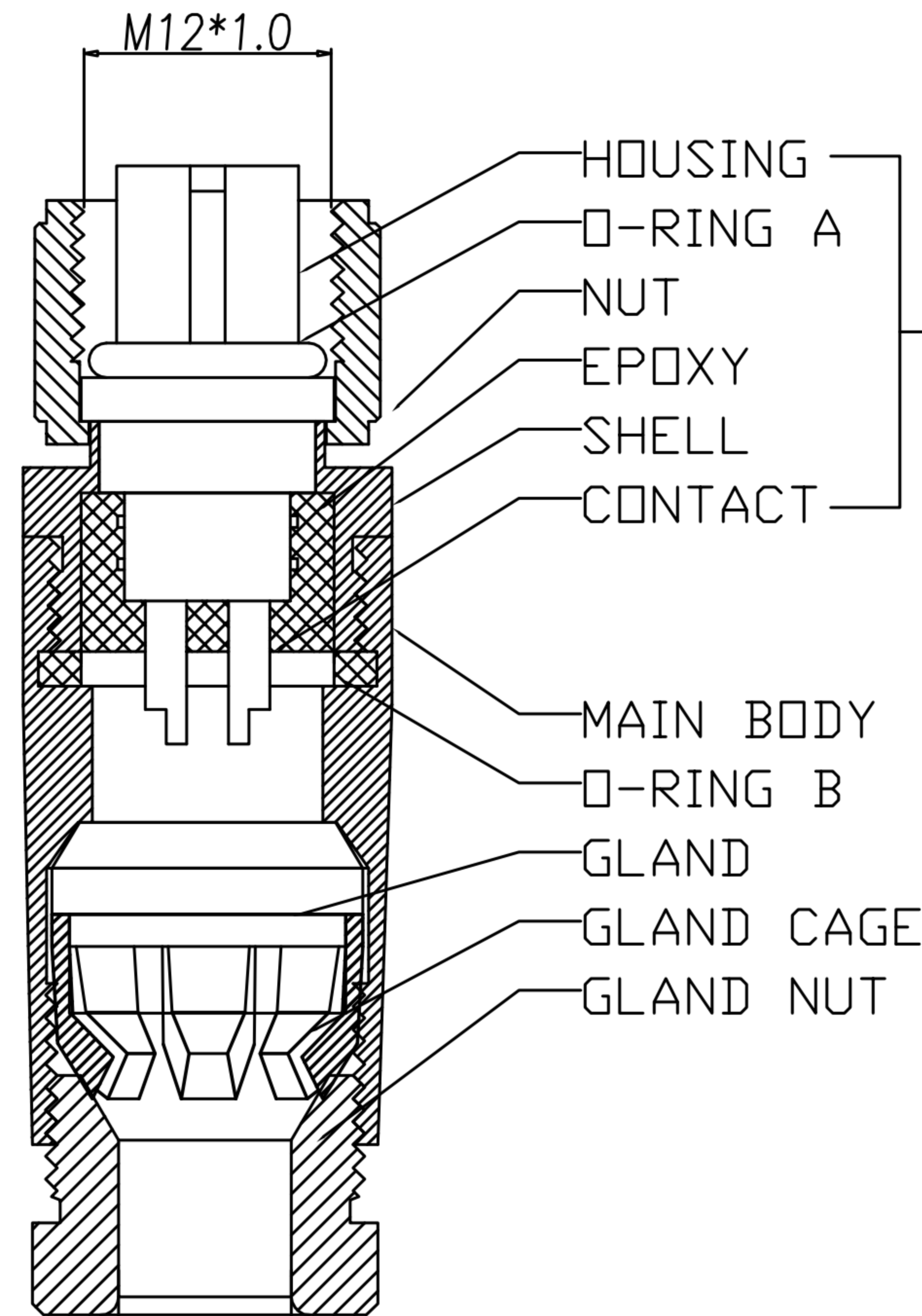
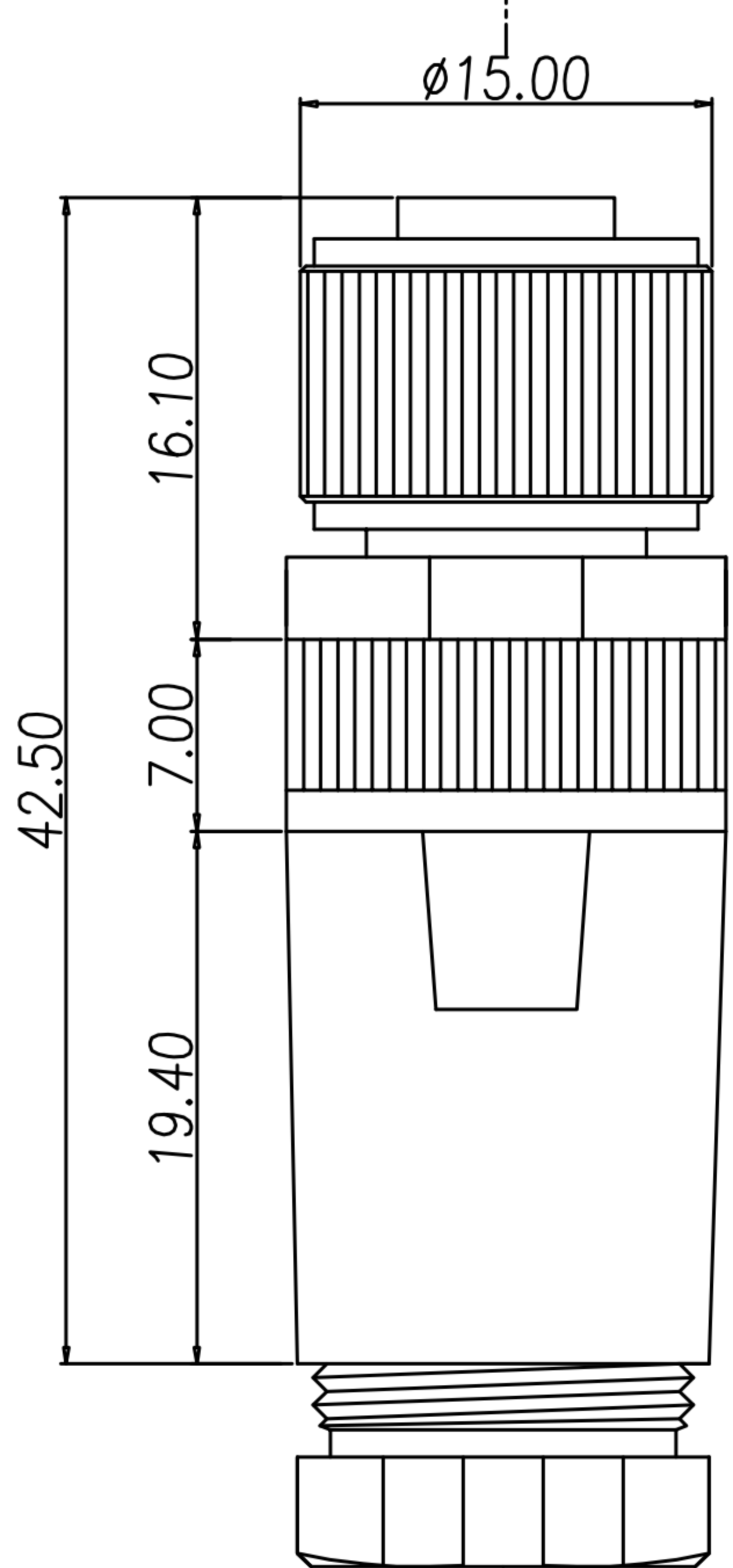

TABLE A

WP-05F2-73 WP-05F2-108-11	WP-04F2-62 WP-04F2-151-11	WP-03F2-53-11 WP-03F2-71-11	WP-03F2-56-11 WP-03F2-74-11	WP-02F2-52-11 WP-02F2-53-11
WP-02F2-52-11	GOLD 10u"	WP-02F2-53-11	GOLD FLASH	
WP-03F2-71-11	GOLD 10u"	WP-03F2-56-11	GOLD FLASH	
WP-04F2-151-11	GOLD 10u"	WP-03F2-53-11	GOLD FLASH	
WP-03F2-74-11	GOLD 10u"	WP-04F2-62	GOLD FLASH	
WP-05F2-108-11	GOLD 10u"	WP-05F2-73	GOLD FLASH	
PART NO	FINISH	PART NO	FINISH	



- MATERIAL :
  - MATERIAL A :
    - HOUSING : PBT UL94V-0 ; COLOR : BLACK.
    - CONTACT : BRASS
    - NUT : ALUMINIUM ALLOY
    - SHELL : ALUMINIUM ALLOY
    - O-RING A : EPDM ; COLOR : BLACK
  - MAIN BODY : ALUMINIUM ALLOY
  - GLAND : SILICONE ; COLOR : BLACK.
  - GLAND CAGE : POM ; COLOR : WHITE.
  - GLAND NUT : ALUMINIUM ALLOY
  - O-RING B : SILICONE ; COLOR : BLACK
- FINISH :
  - MATERIAL A :
    - CONTACT : SEE TABLE A
    - NUT : SATIN NICKEL PLATED.
    - SHELL : SATIN NICKEL PLATED.
  - MAIN BODY : SATIN NICKEL PLATED.
  - GLAND NUT : SATIN NICKEL PLATED.
- ELECTRICAL SPECIFICATION :
  - Rated current : 4A
  - Rated voltage : 2~4PIN 250V ; 5PIN 60V
  - Water proof : IP67
- Environmental :
  - Operation Temperature : -20℃~85℃

7.50 RECOMMEND CABLE OD=5.0mm~6.0mm

DRAWN	Ku Chou	APP'D	Emily Suen	UNIT	mm	TOLERANCE		广东科斯达电子科技有限公司 GUANG DONG KE SI DA ELECTRONIC TECHNOLOGY CO., LTD.	TITLE	M12 (F) A-coded Assembly type			SHEET	1
CHK'D	Emily Suen			SCALE	1:1				PART NO.	SEE TABLE A	DWG NO.	QC5210	VERSION	A