

CUSTOMER DRAWING

REV.	DESCRIPTION	APPROVED BY	DATE	ECN NO.
A	RELEASE	LEO	11/11/21*	
B				
C				
D				

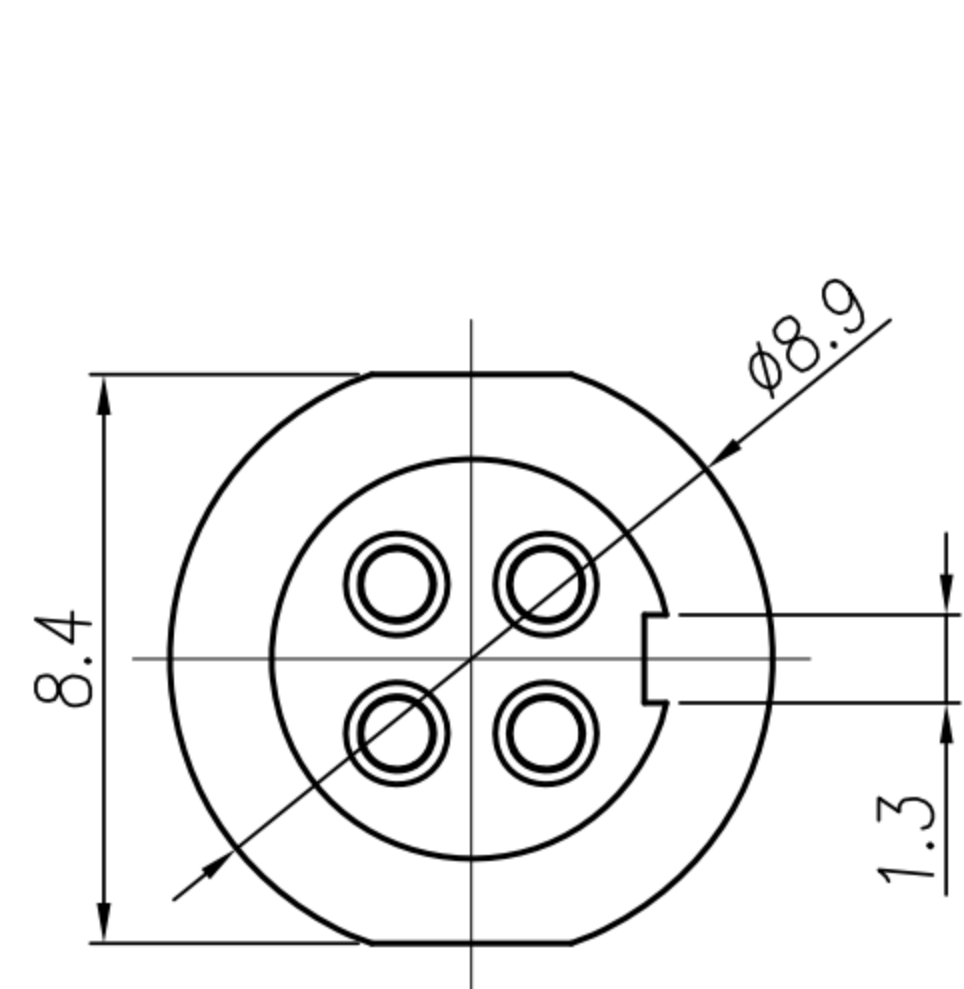

HOUSING & CONTACT & O-RING

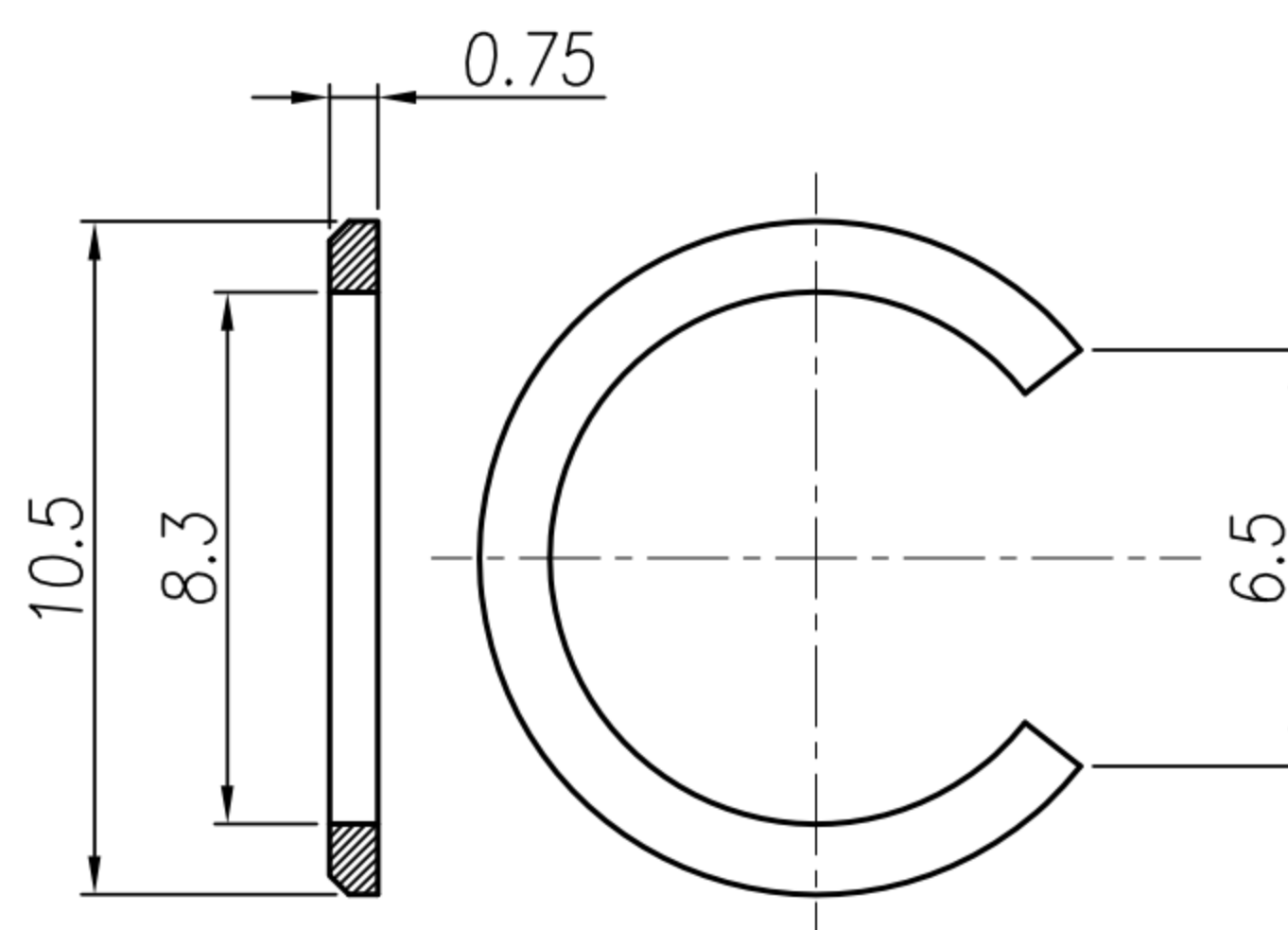
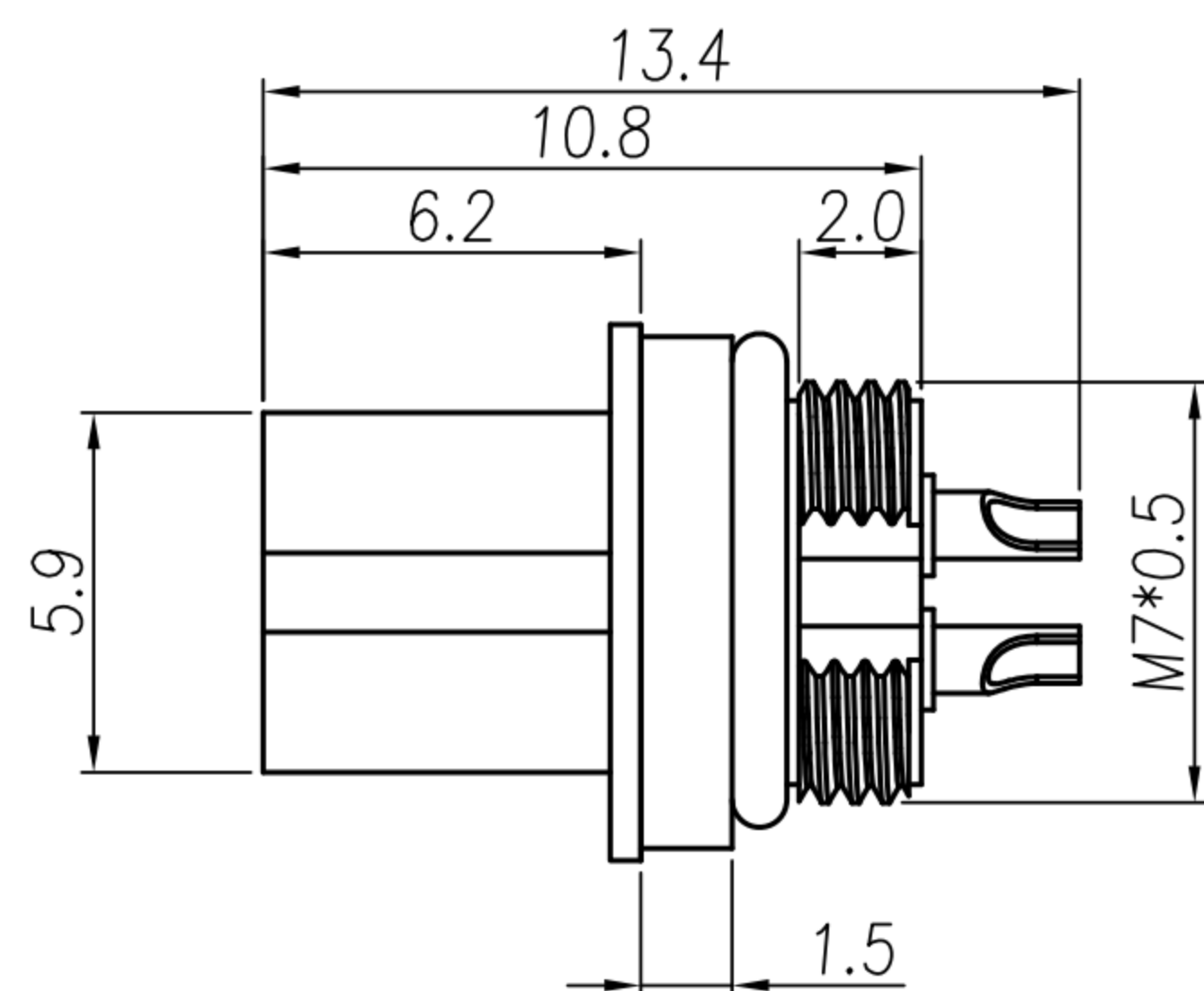

SPRING

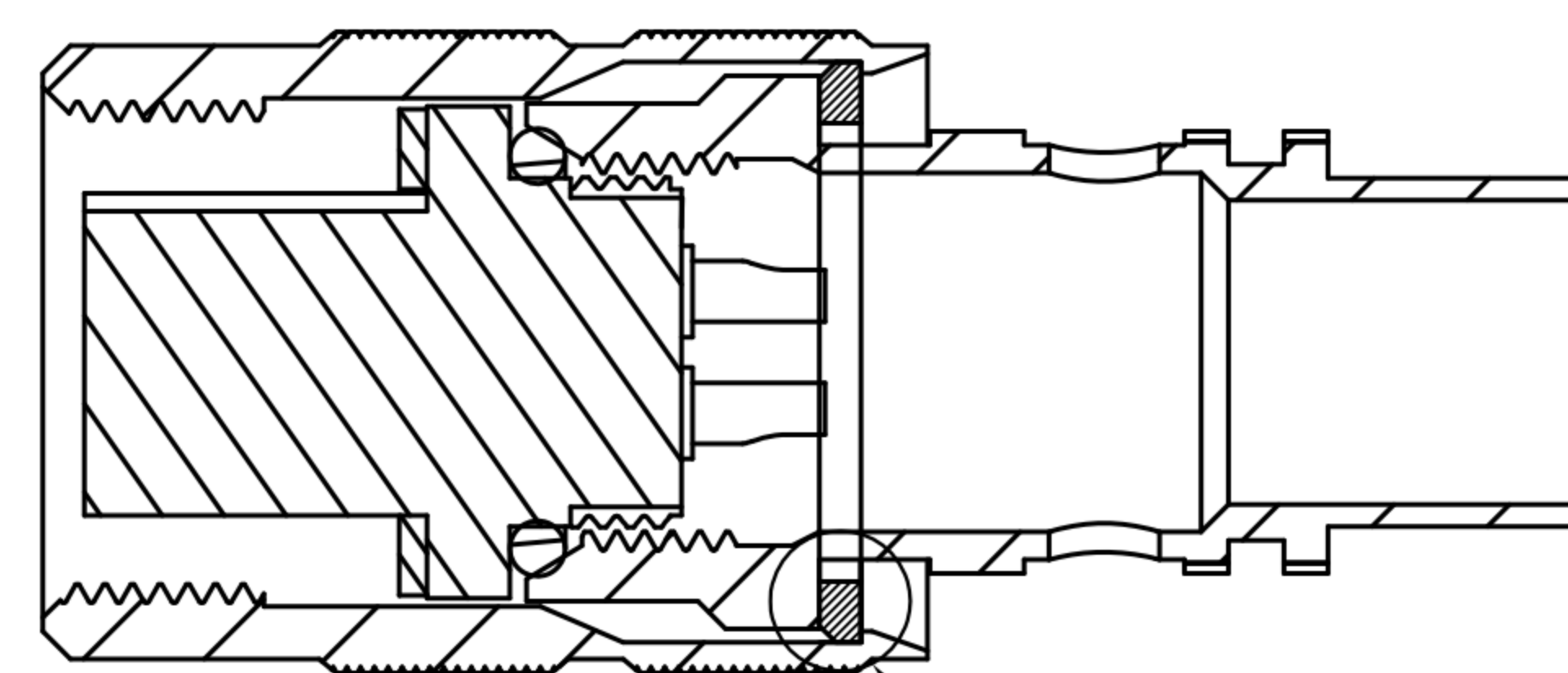

ASS'Y

將不鏽鋼環穿入到這個位置
(倒角朝對插口面)

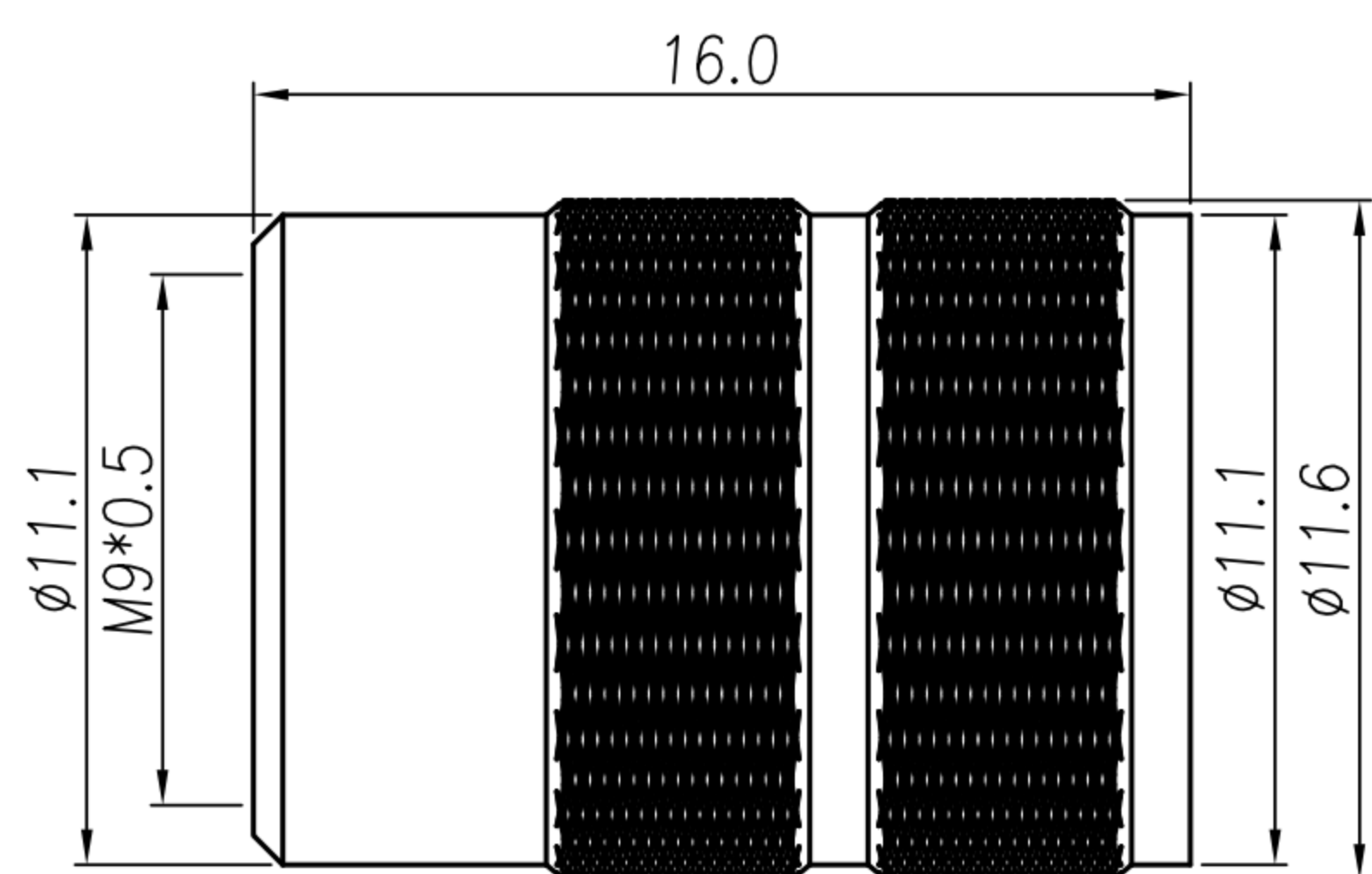

NUT

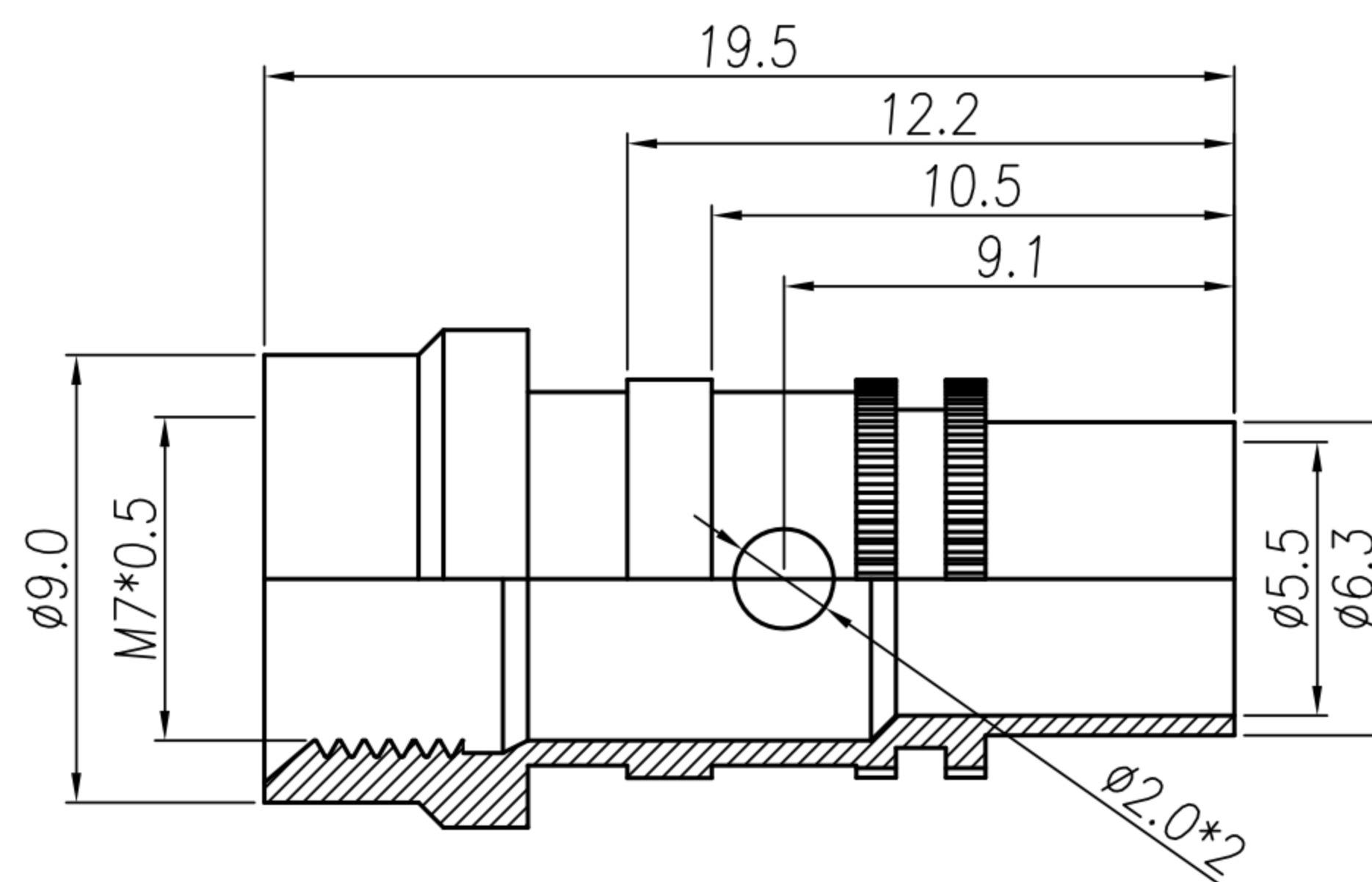

SHELL

- MATERIAL :
 - 1-1. HOUSING : PA66 UL94V-0 ; COLOR : BLACK
 - 1-2. CONTACT : BRASS.
 - 1-3. NUT : BRASS.
 - 1-4. O-RING A : EPDM ; COLOR : BLACK.
 - 1-5. O-RING B : SILICONE ; COLOR : BLACK.
 - 1-6. SPRING : STAINLESS STEEL.
 - 1-7. SHELL : BRASS.
- FINISH :
 - 2-1. CONTACT : GOLD FLASH
 - 2-2. NUT : NICKEL PLATED OVER ALL
 - 2-3. SHELL : NICKEL PLATED OVER ALL
- ELECTRICAL SPECIFICATION :
 - 3-1. Rated current(40°C) : 2~3P 4A; 4~5P 3A; 7~8P 1A
 - 3-2. Rated voltage : 125V
 - 3-3. Water proof : IP67
- Environmental :
 - 4-1. Operation Temperature : -25°C~70°C

WP-02F2-104-11	WP-03F2-171-11	WP-04F2-283-11	WP-05F2-217-11	WP-07F2-22-11	WP-08F2-134-11

DRAWN	LEO	APPEND	Emily Suen	UNIT	mm	TOLERANCE				TITLE	M9 (F) 線端成型式 (接地銅管)			SHEET	
CHK'D	Emily Suen			SCALE	1:1					PART NO.	SEE TABLE A	DWG NO.	QC10288	VERSION	