

# CUSTOMER DRAWING

REV.	DESCRIPTION	APPROVED BY	DATE	ECN NO.
A	RELEASE	Fido Weng		
B				
C				

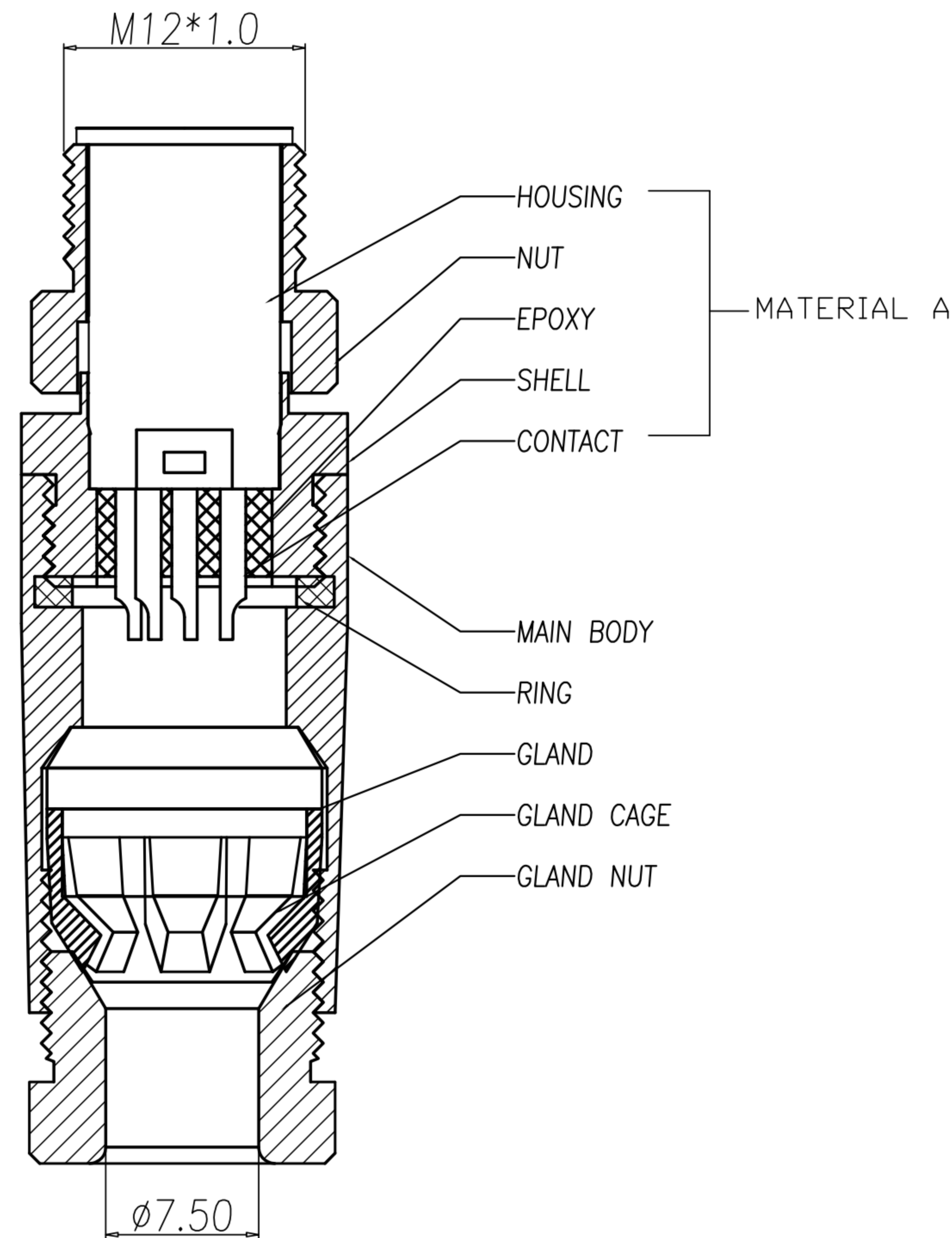
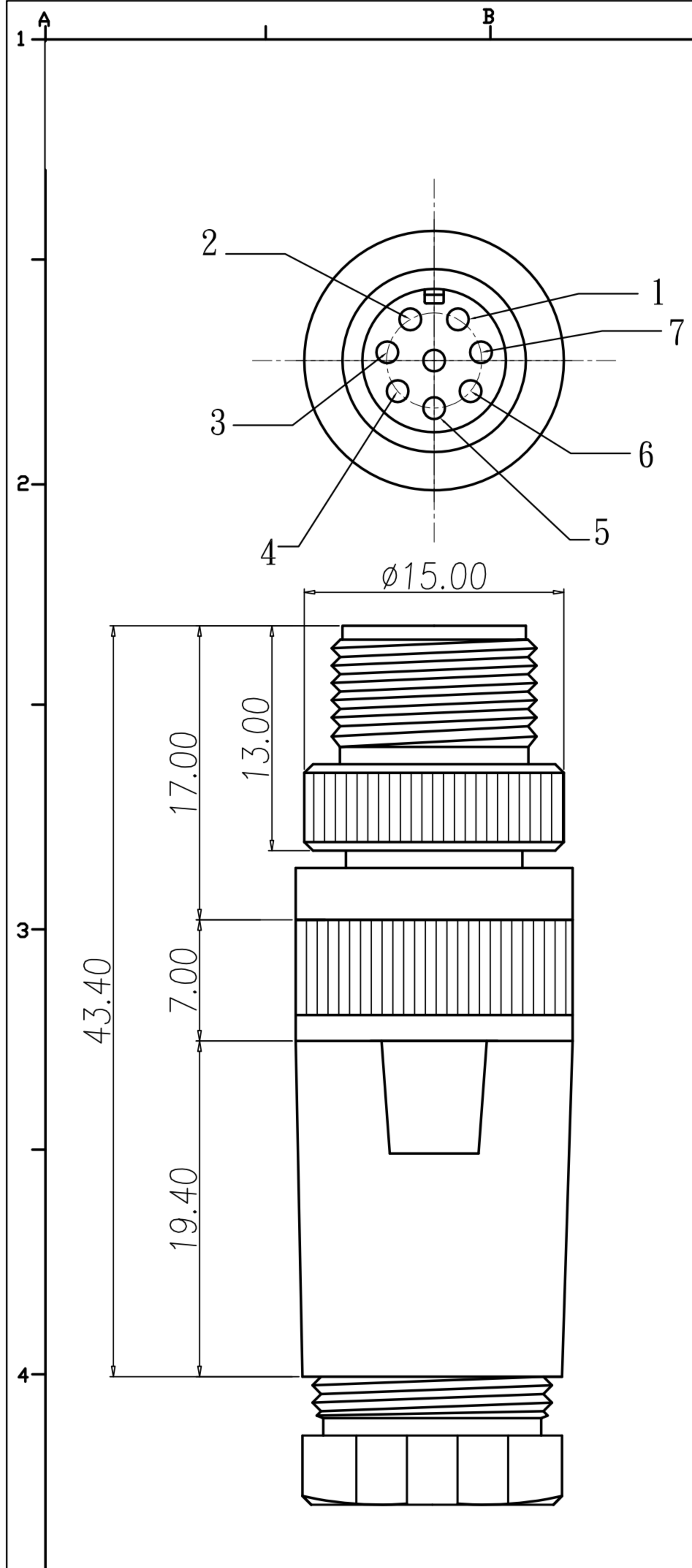

1. MATERIAL :
  - 1-1. MATERIAL A :
    - a. HOUSING : PBT UL94V-0 ; COLOR : BLACK.
    - b. CONTACT : BRASS
    - c. NUT : ALUMINIUM ALLOY
    - d. SHELL : ALUMINIUM ALLOY
  - 1-2. MAIN BODY : ALUMINIUM ALLOY
  - 1-3. GLAND : SILICONE COLOR : BLACK.
  - 1-4. GLAND CAGE : POM ; COLOR : BLACK.
  - 1-5. GLAND NUT : ALUMINIUM ALLOY.
  - 1-6. O-RING : SILICONE ; COLOR : BLACK
2. FINISH :
  - 2-1. MATERIAL A :
    - a. CONTACT : SEE TABLE A
    - b. NUT : SATIN NICKEL PLATED.
    - c. SHELL : SATIN NICKEL PLATED.
  - 2-2. MAIN BODY : SATIN NICKEL PLATED.
  - 2-3. GLAND NUT : SATIN NICKEL PLATED.
3. ELECTRICAL SPECIFICATION :
  - 3-1. Rated current : 2A
  - 3-2. Rated voltage : 30V
  - 3-3. Water proof : IPX7
4. Environmental :
  - 4-1. Operation Temperature : -20°C~85°C

TABLE A

WP-08M2-48-11	GOLD 10u"
WP-08M2-27	GOLD FLASH
WP-07M2-08-11	GOLD 10u"
WP-07M2-07-11	GOLD FLASH
WP-06M2-50-11	GOLD 10u"
WP-06M2-49-11	GOLD FLASH
PART NO	FINISH

WP-06M2-50-11	WP-07M2-08-11	WP-08M2-48-11
WP-06M2-49-11	WP-07M2-07-11	WP-08M2-27

DRAWN	Ku Chou	APP'D	Emily Suen	UNIT	mm	TOLERANCE		广东科斯达电子科技有限公司 GUANG DONG KE SI DA ELECTRONIC TECHNOLOGY CO., LTD.	TITLE	M12 (M) A-coded Assembly type			SHEET	VERSION A
CHK'D	Emily Suen			SCALE	1:1	.x ±0.20 .xx ±0.10 .xxx ±0.05 .xxxx ±0.03 ANGULA ±1°			PART NO.	SEE TABLE A	DWG NO.	QC5876		