

CUSTOMER DRAWING

REV.	DESCRIPTION	APPVL. BY	DATE	ECN NO.
△	Del Table A	Fido Weng	20/03/09*	ECN-09032
△	ADD P/N	Fido Weng	12/02/14*	
△	更改油封材質	KU	26/06/18*	

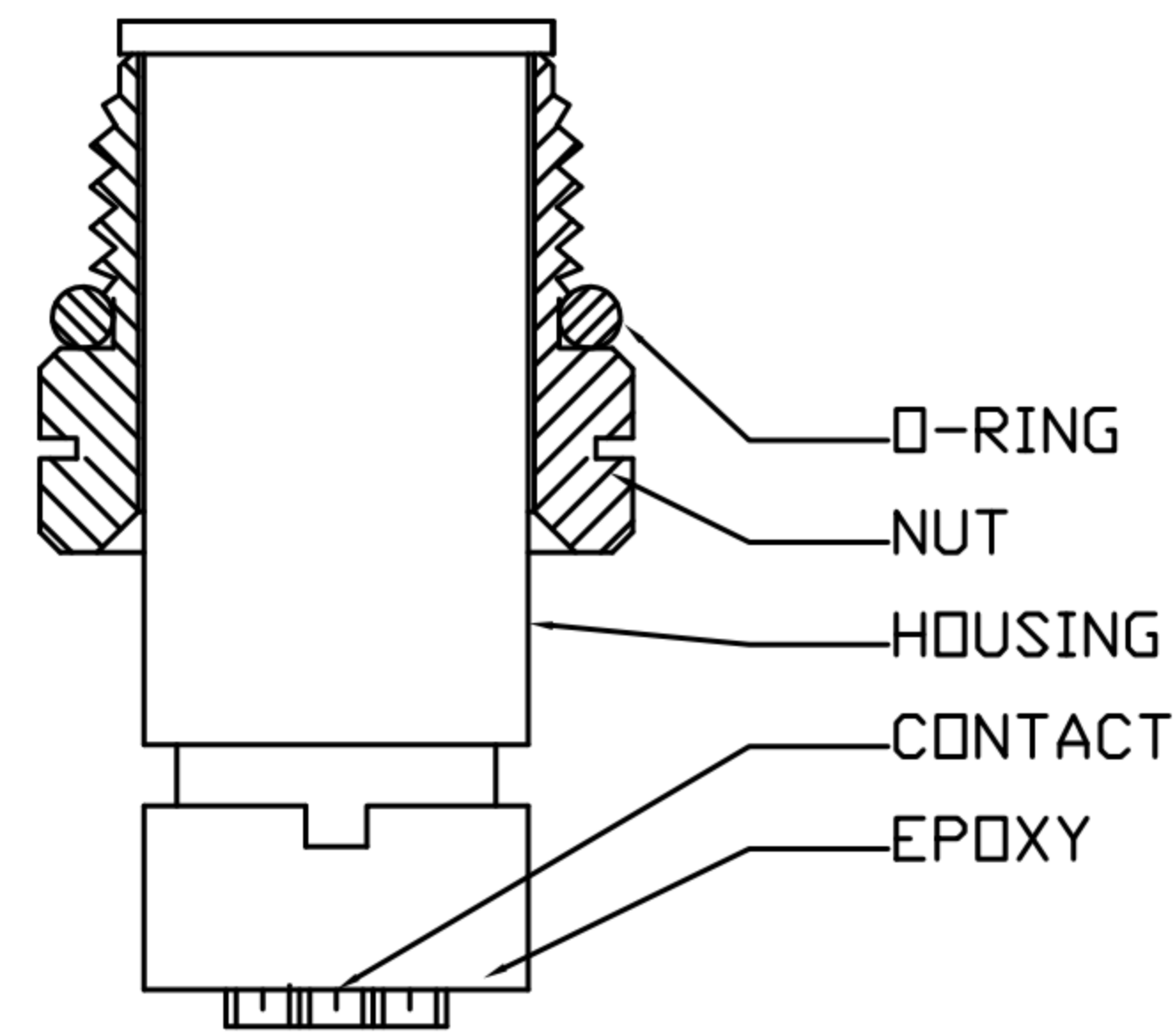

ASS'Y

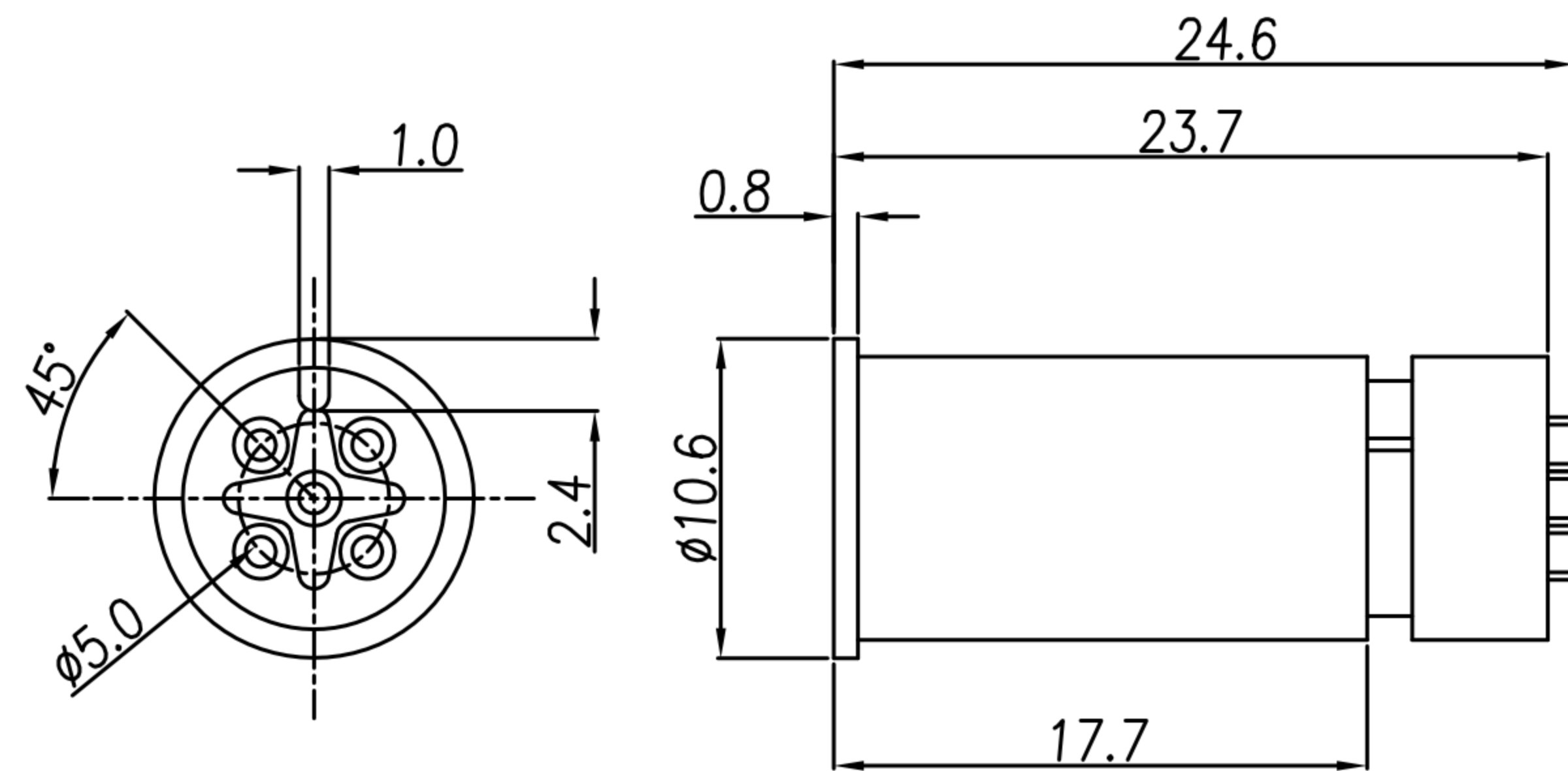
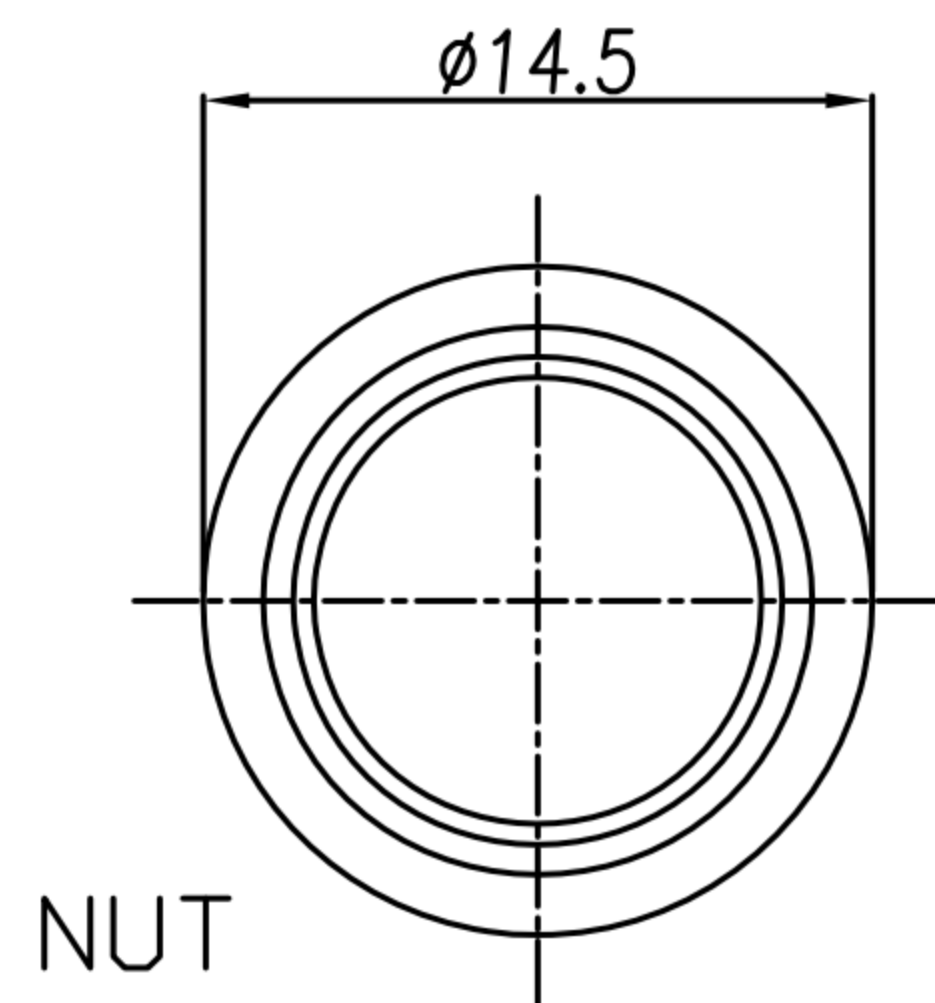
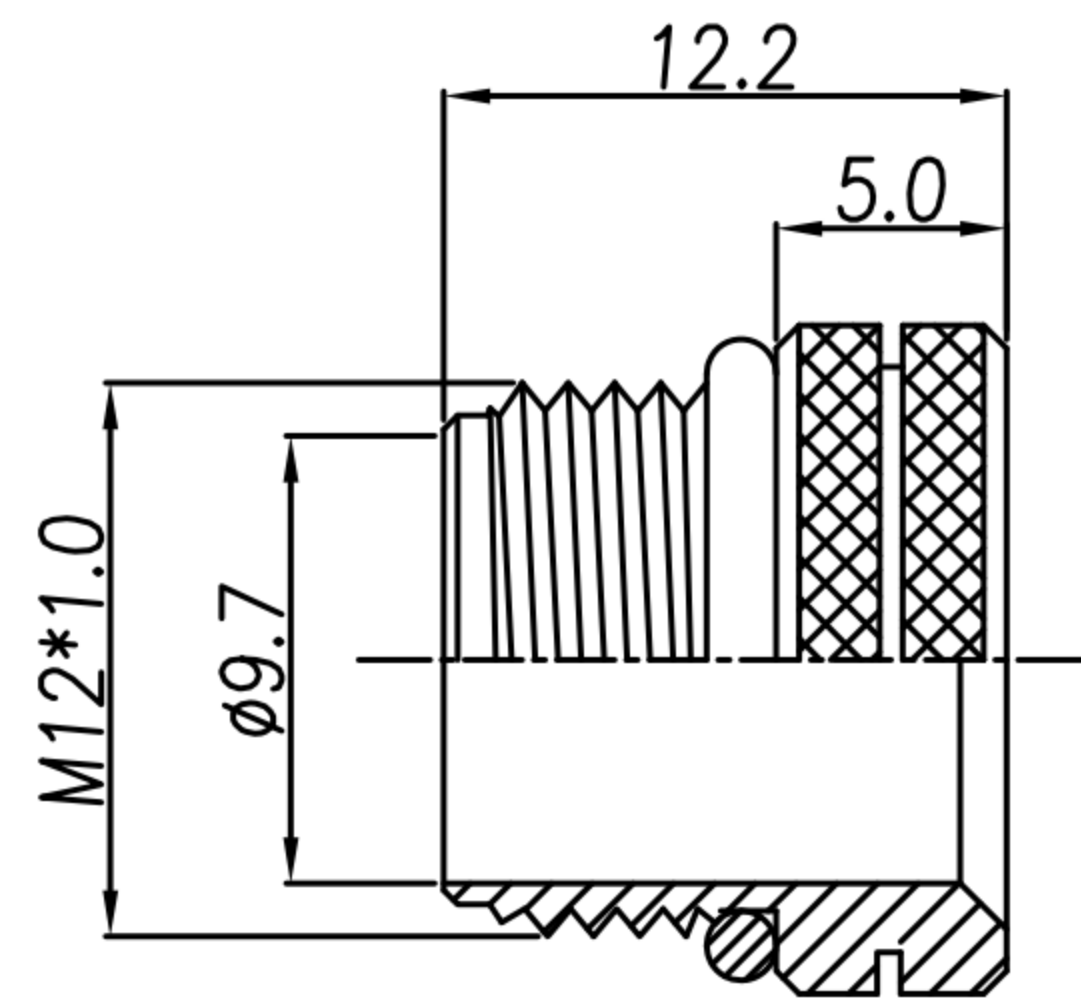

NUT

TABLE A

5PIN	4PIN
WP-05M2-103-11 WPM12-05M2-01-11 WPM12-05M2-02 WP-05M2-60 WP-05M2-230-11	WP-04M2-121-11 WP-04M2-15 WPM12-04M2-02 WP-04M2-249-11 WP-04M2-269-11
3PIN	3PIN
WP-03M2-64-11 WPM12-03M2-02 WP-03M2-127-11	WP-03M2-25 WP-03M2-65-11 WP-03M2-131-11
2PIN	2PIN
WP-02M2-02	WP-02M2-35-11

1. MATERIAL :
 - 1-1. HOUSING : SEE TABLE A UL94V-0 ; COLOR : BLACK.
 - 1-2. CONTACT : BRASS
 - 1-3. NUT : SEE TABLE A
 - 1-4. O-RING : SEE TABLE A ; COLOR : SEE TABLE A
2. FINISH :
 - 2-1. CONTACT : SEE TABLE A
 - 2-2. NUT : SEE TABLE A
3. ELECTRICAL SPECIFICATION :
 - 3-1. Rated current : 4A
 - 3-2. Rated voltage : 2~4PIN 250V ; 5PIN 60V
 - 3-3. Water proof : IP67
4. Environmental :
 - 4-1. Operation Temperature : -40℃~85℃

WP-04M2-269-11	NYLON 66	BRASS	NICKEL PLATED	10u" GOLD PLATED	EPDM(BLACK)
WP-05M2-230-11	NYLON 66	BRASS	NICKEL PLATED	10u" GOLD PLATED	EPDM(BLACK)
WP-04M2-249-11	PBT	STAINLESS STEEL 316	PASSIVATION	10u" GOLD PLATED	EPDM(BLACK)
WP-03M2-131-11	PBT	STAINLESS STEEL 316	PASSIVATION	10u" GOLD PLATED	EPDM(BLACK)
WP-03M2-127-11	PBT	STAINLESS STEEL 316	PASSIVATION	10u" GOLD PLATED	EPDM(BLACK)
WP-02M2-93-11	PBT	STAINLESS STEEL 316	PASSIVATION	10u" GOLD PLATED	EPDM(BLACK)
WP-05M2-103-11	PBT	BRASS	NICKEL PLATED	GOLD FLASH PLATED	NBR(BLACK)
WP-05M2-60	PBT	BRASS	NICKEL PLATED	GOLD FLASH PLATED	EPDM(BLACK)
WP-04M2-121-11	PBT	BRASS	NICKEL PLATED	GOLD FLASH PLATED	EPDM(BLACK)
WP-03M2-64-11	PBT	BRASS	NICKEL PLATED	GOLD FLASH PLATED	EPDM(BLACK)
WP-03M2-65-11	PBT	BRASS	NICKEL PLATED	GOLD FLASH PLATED	EPDM(BLACK)
WPM12-05M2-01-11	PBT	BRASS	NICKEL PLATED	10u" GOLD PLATED	NBR(BLACK)
WPM12-05M2-02	PBT	BRASS	NICKEL PLATED	10u" GOLD PLATED	EPDM(BLACK)
WP-04M2-15	PBT	BRASS	NICKEL PLATED	10u" GOLD PLATED	SILICONE(GREEN)
WPM12-04M2-02	PBT	BRASS	NICKEL PLATED	10u" GOLD PLATED	EPDM(BLACK)
WPM12-03M2-02	PBT	BRASS	NICKEL PLATED	10u" GOLD PLATED	EPDM(BLACK)
WP-03M2-25	PBT	BRASS	NICKEL PLATED	10u" GOLD PLATED	EPDM(BLACK)
WP-02M2-02	PBT	BRASS	NICKEL PLATED	10u" GOLD PLATED	EPDM(BLACK)
WP-02M2-35-11	PBT	BRASS	NICKEL PLATED	10u" GOLD PLATED	EPDM(BLACK)
PART No.	HOUSING	MATERIAL(NUT)	FINISH(NUT)	FINISH(CONTACT)	O-RING(COLOR)

DRAW	Ku Chou	APPVL	Fido Weng	UNIT	mm	TOLERANCE		广东科斯达电子科技有限公司 GUANG DONG KE SI DA ELECTRONIC TECHNOLOGY CO., LTD.	TITLE	防水頭 M12 (M)線端			SHEET	1/1
CHECK	Emily Suen	SCALE	1:1	TOLERANCE	.x ±0.20 .xx ±0.10 .xxx ±0.05 .xxxx ±0.03 ANGULA ±1°	PART NO.			SEE TABLE A	DWG NO.	QC1467	VERSION	F	