

CUSTOMER DRAWING

REV.	DESCRIPTION	APPROVED BY	DATE	ECN NO.
△A	RELEASE	Fido Weng		
△B				
△C				

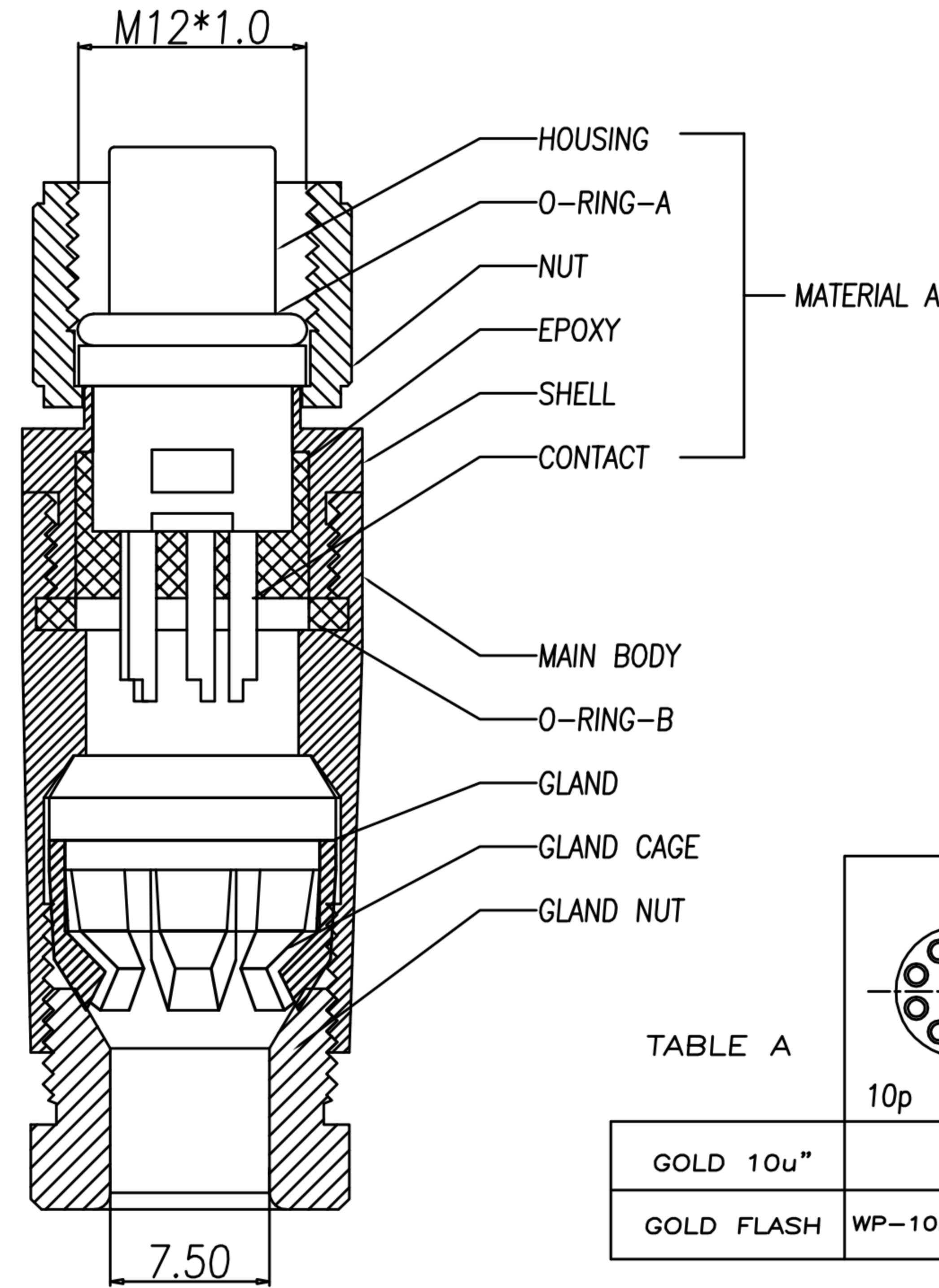
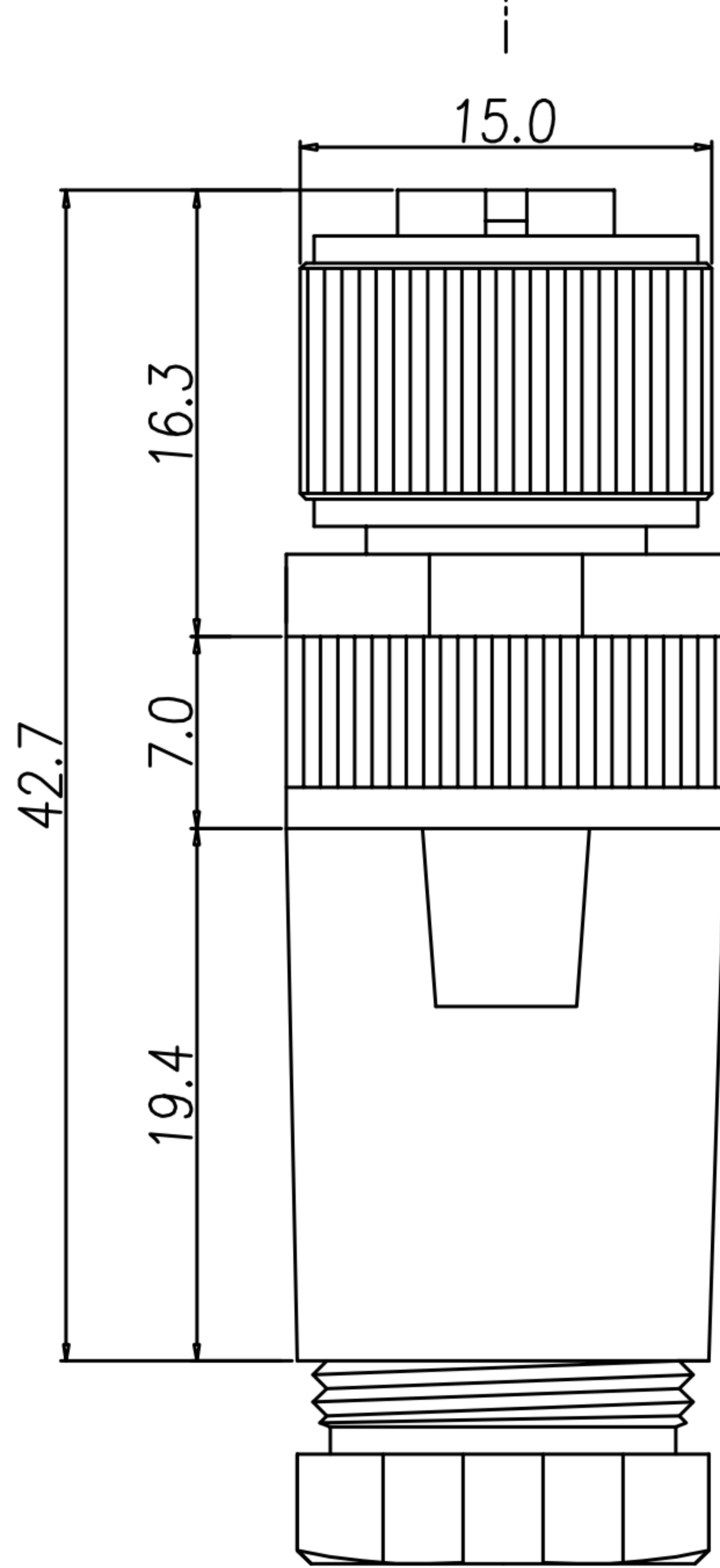
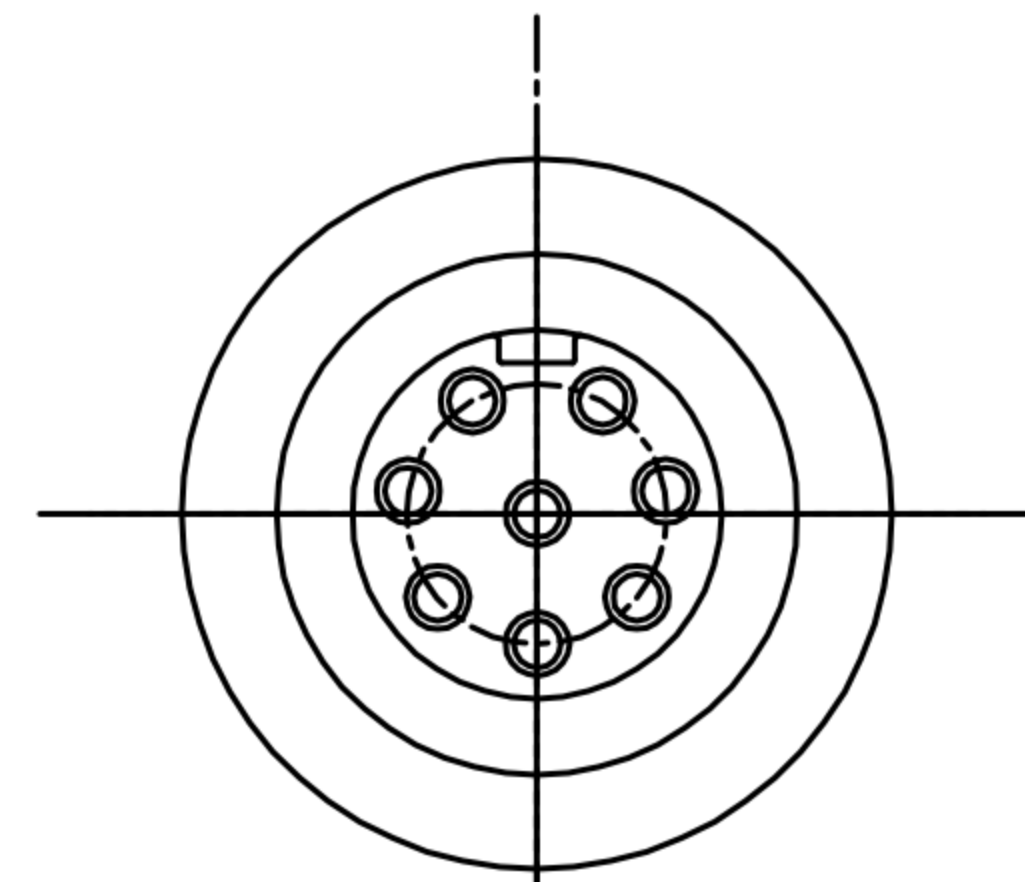

1. MATERIAL :
 - 1-1. MATERIAL A :
 - a. HOUSING : PBT UL94V-0 ; COLOR : BLACK.
 - b. CONTACT : BRASS
 - c. NUT : ALUMINIUM ALLOY
 - d. SHELL : ALUMINIUM ALLOY
 - e. O-RING : EPDM ; COLOR : BLACK
 - 1-2. MAIN BODY : ALUMINIUM ALLOY
 - 1-3. GLAND : SILICONE ; COLOR : BLACK.
 - 1-4. GLAND CAGE : POM ; COLOR : WHITE.
 - 1-5. GLAND NUT : ALUMINIUM ALLOY
 - 1-6. O-RING B : SILICONE ; COLOR : BLACK
2. FINISH :
 - 2-1. MATERIAL A :
 - a. CONTACT : SEE TABLE A
 - b. NUT : SATIN NICKEL PLATED.
 - c. SHELL : SATIN NICKEL PLATED.
 - 2-2. MAIN BODY : SATIN NICKEL PLATED.
 - 2-3. GLAND NUT : SATIN NICKEL PLATED.
3. ELECTRICAL SPECIFICATION :
 - 3-1. Rated current : 2A
 - 3-2. Rated voltage : 30V
 - 3-3. Water proof : IP67
4. Environmental :
 - 4-1. Operation Temperature : -20℃~85℃

TABLE A

	10p	8p	7p	6p-Standard	6p
GOLD 10u"		WP-08F2-69-11			
GOLD FLASH	WP-10F2-08-11	WP-08F2-33	WP-07F2-24-11	WP-06F2-93-11	WP-06F2-92-11

DRAWN	Ku Chou	APP'D	Emily Suen	UNIT	mm	TOLERANCE			广东科斯达电子科技有限公司 GUANG DONG KE SI DA ELECTRONIC TECHNOLOGY CO., LTD.	TITLE	M12 (F) A-coded Assembly type			SHEET	1
CHK'D	Emily Suen			SCALE	1:1					PART NO.	SEE TABLE A	DWG NO.	QC5878	VERSION	A