

CUSTOMER DRAWING

REV.	DESCRIPTION	APPVL. BY	DATE	ECN NO.
A	RELEASE	Fido Weng	13/02/09'	
B	ADD RECOMMENDPANEL CUT-OUT	Fido Weng	28/03/19'	
C				

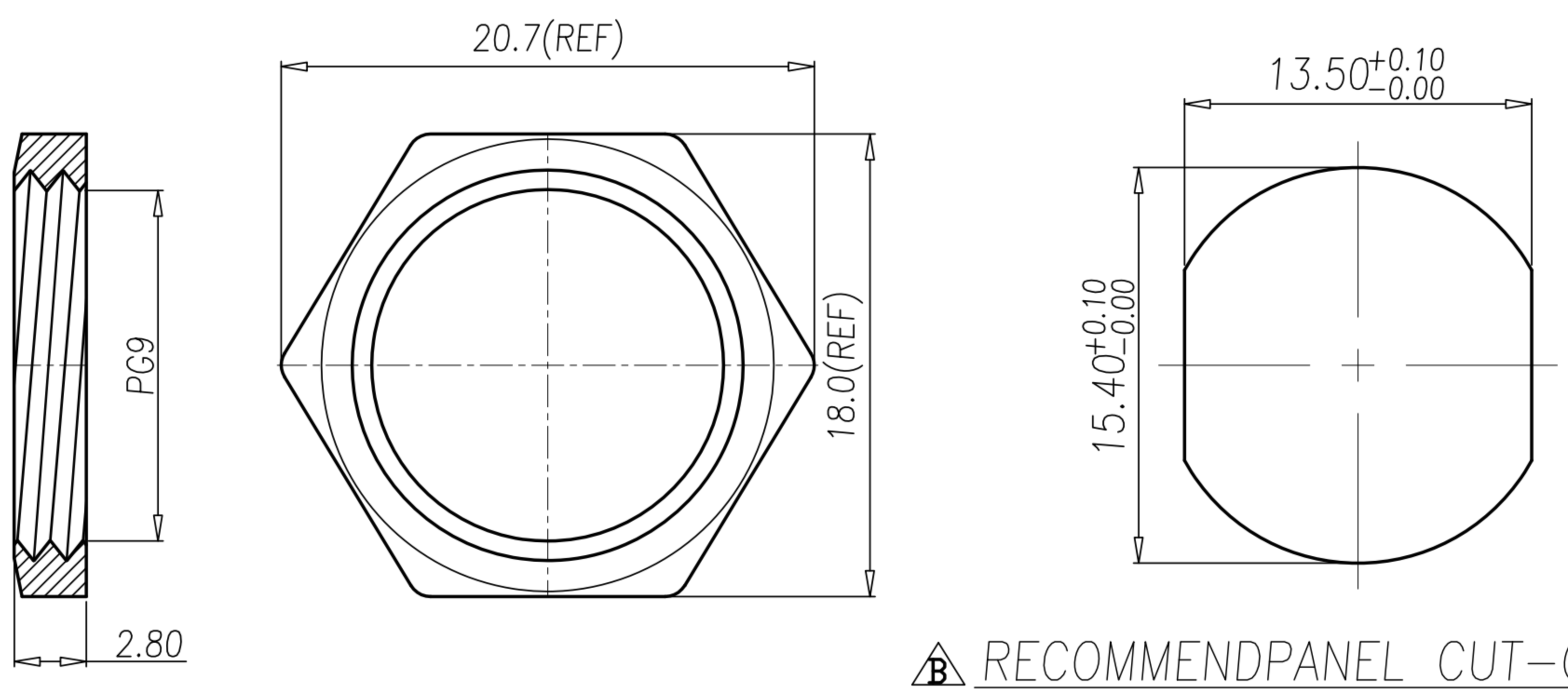
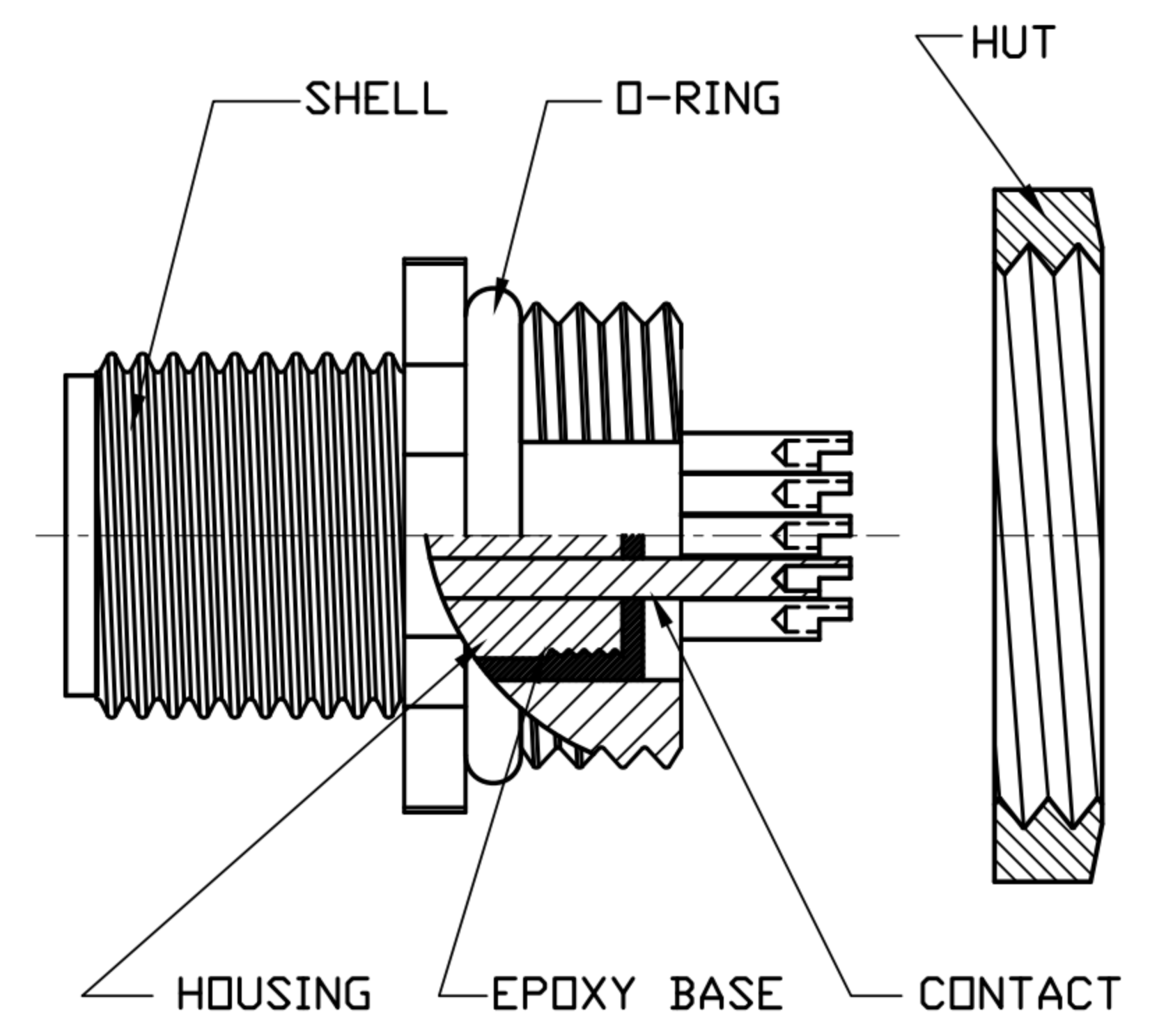
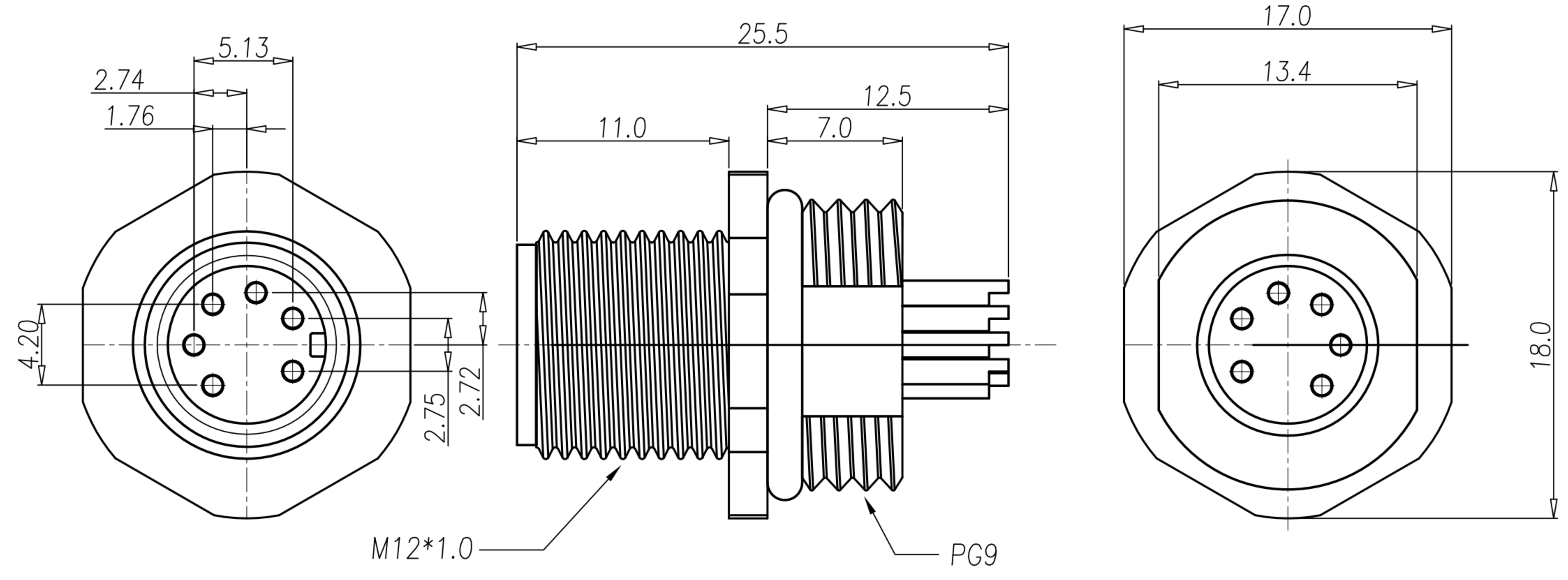

B RECOMMENDPANEL CUT-OUT

- NOTE**
- MATERIAL :**
 - 1-1. HOUSING : PBT UL94V-0 ; COLOR : BLACK
 - 1-2. CONTACT : BRASS
 - 1-3. SHELL : BRASS
 - 1-4. NUT : BRASS
 - 1-5. O-RING : NBR ; COLOR : BLACK
 - FINISH :**
 - 2-1. CONTACT : 10 MICRO INCHES MIN. GOLD PLATED UNDER PLATE : NICKEL
 - 2-2. SHELL : NICKEL PLATED
 - 2-3. NUT : NICKEL PLATED
 - ELECTRICAL SPECIFICATION :**
 - 3-1. Rated current : 2A
 - 3-2. Rated Voltage : 30V
 - 3-3. Water proof : IP67
 - Environmental :**
 - 4-1. Operation Temperature : -40°C~85°C

TABLE A

WP-06M2-09
WP-06M2-94-11

DRAW	Mark Kao	APPVL	Emily Suen	UNIT	mm	TOLERANCE		广东科斯达电子科技有限公司 GUANG DONG KE SI DA ELECTRONIC TECHNOLOGY CO., LTD.	TITLE	WP M12 6PIN(M) 6PIN(M) (PG9)A Code			SHEET	1
CHECK	Ku Chou			SCALE	1:1	.x ±0.20 .xx ±0.10 .xxx ±0.05 .xxxx ±0.03 ANGULA ±1°			PART NO.	SEE TABLE A	DWG NO.	QC4086	VERSION	