

# CUSTOMER DRAWING

REV.	DESCRIPTION	APPROVED BY	DATE	ECN NO.
A	RELEASE	Fido Weng	22/10/14'	
B	ADD P/N	KU CHOU	22/01/21'	
C				

TABLE A B

WP-06F3-06-11	WP-06F3-07-11
WP-08F2-57-11	WP-07F3-02-11

Pin Assignments  
Front View

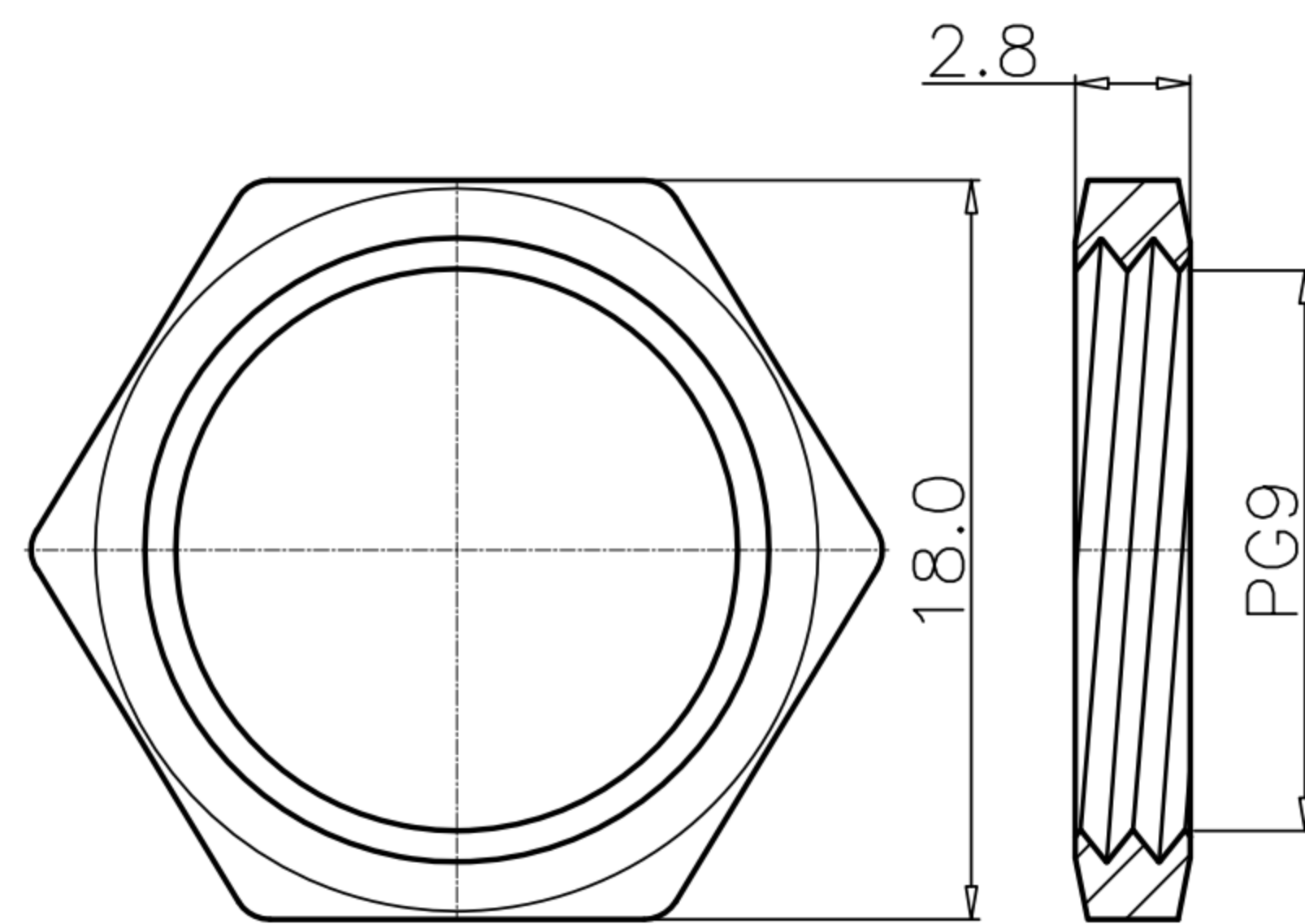
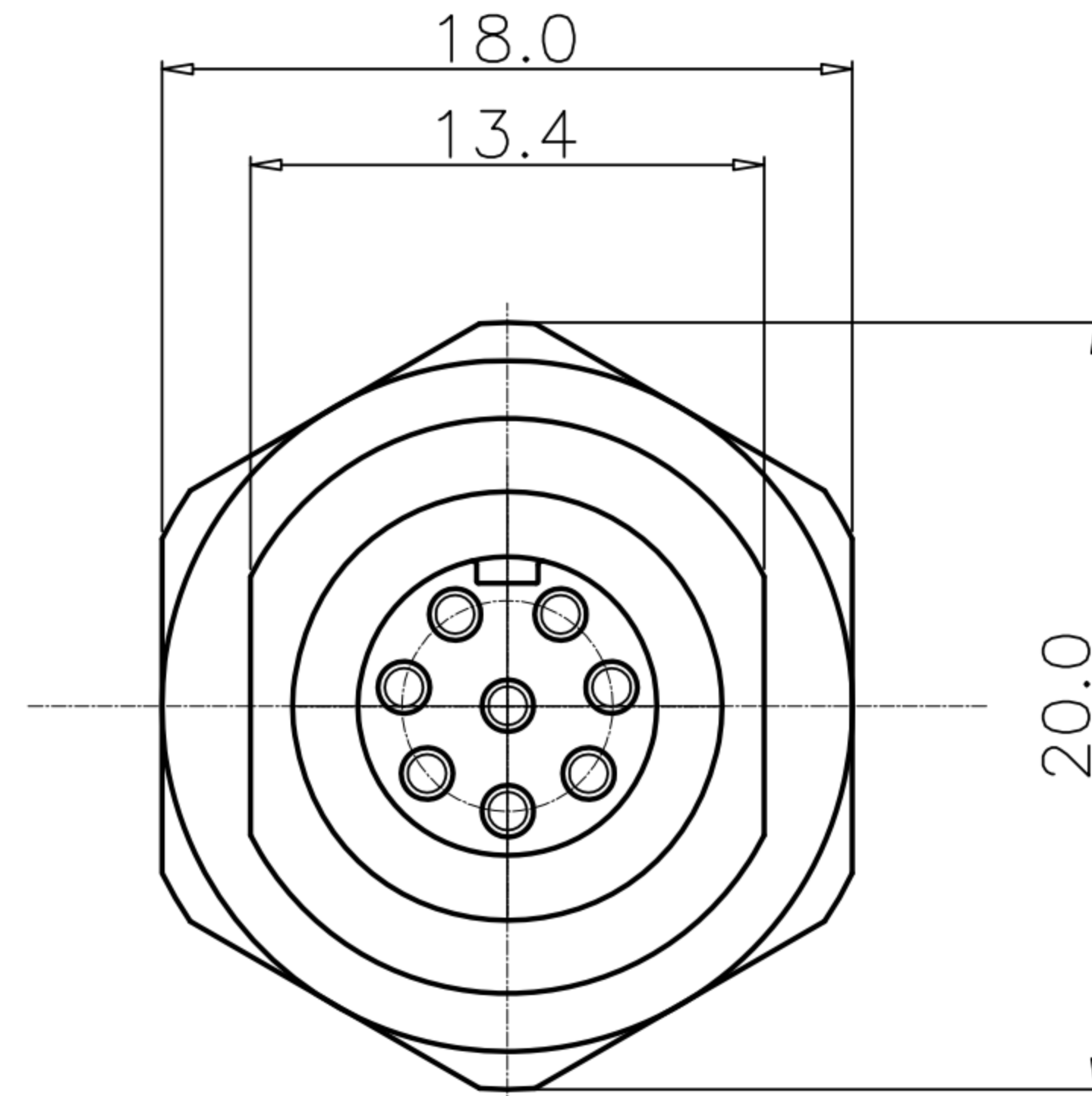
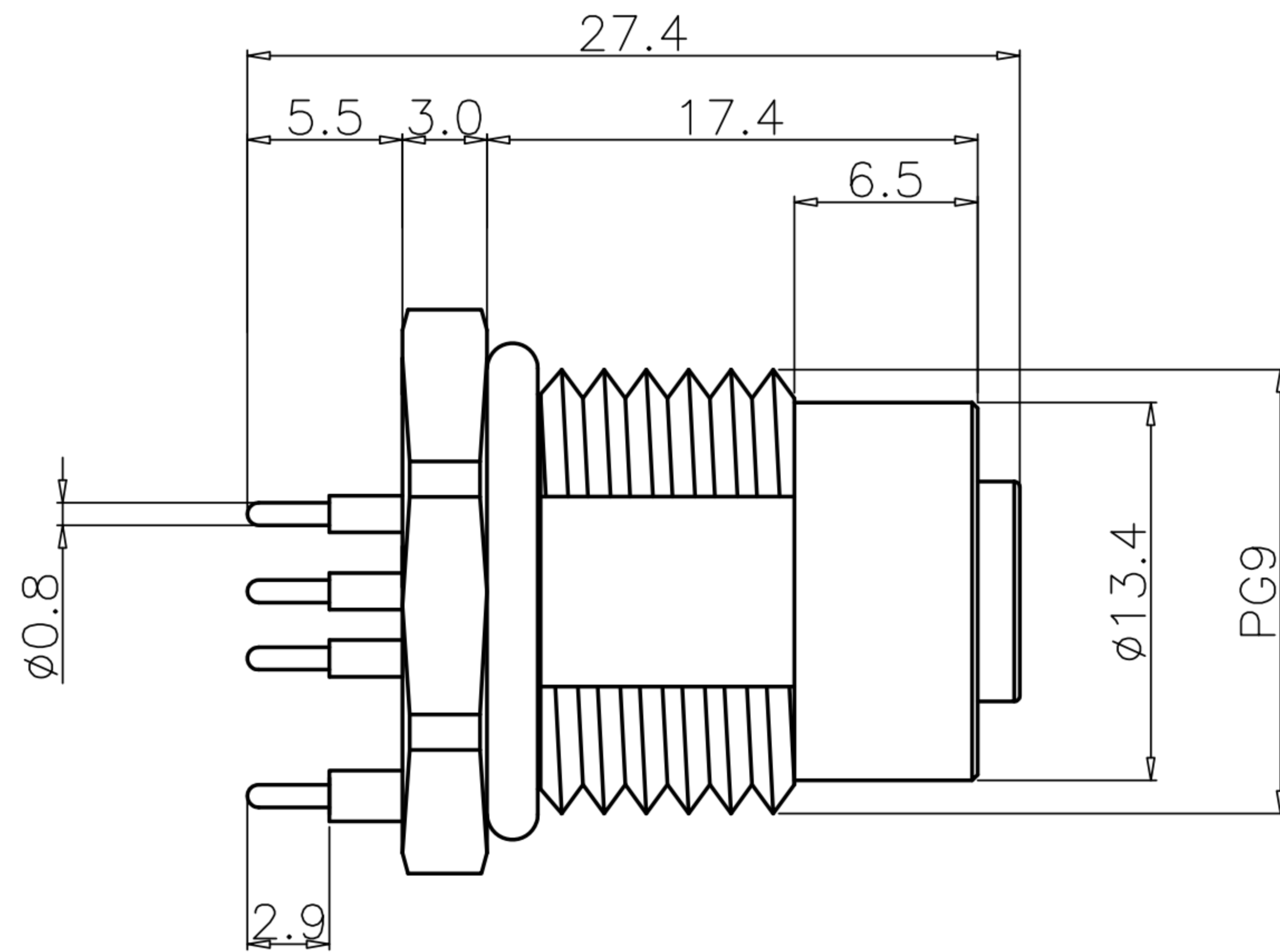

NUT

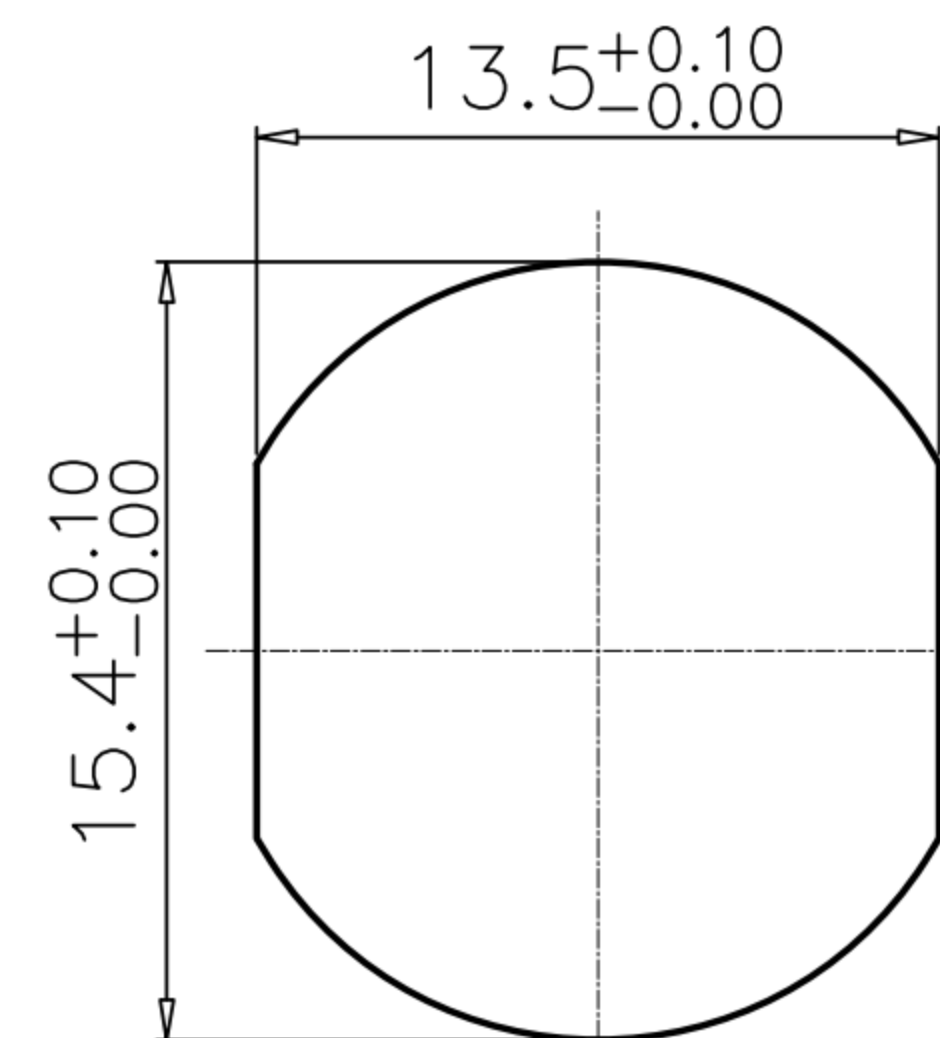

RECOMMEND PANEL CUT-OUT RECOMMEND P.C.B LAYOUT

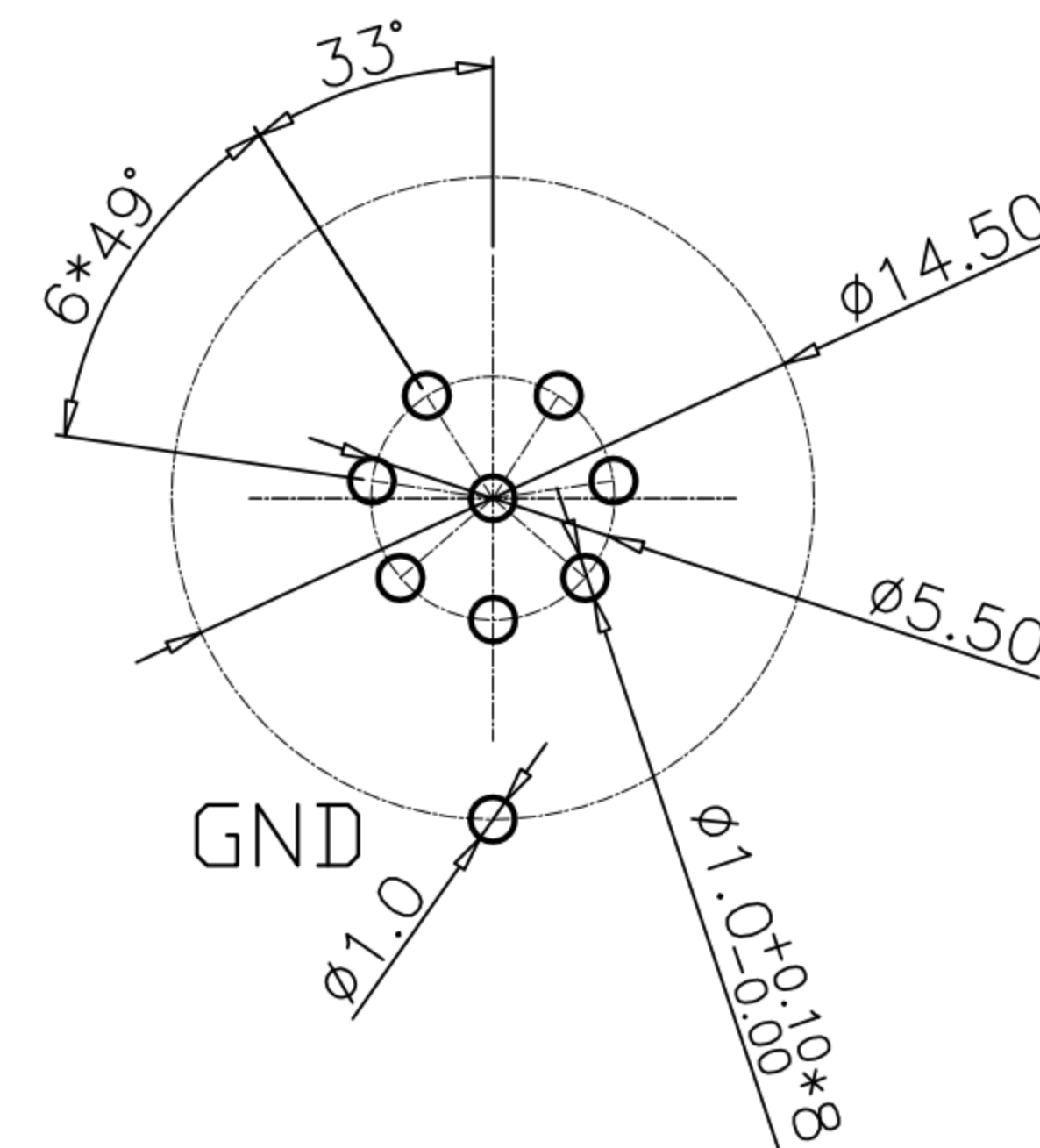

- MATERIAL :
  - 1-1. HOUSING : PBT UL94V-0 ; COLOR : BLACK
  - 1-2. CONTACT : BRASS
  - 1-3. NUT : BRASS
  - 1-4. SHELL : BRASS
  - 1-5. O-RING : EPDM
- FINISH :
  - 2-1. CONTACT : 10 MICRO INCHES MIN. GOLD PLATED
  - UNDER PLATE : NICKEL
  - 2-2. NUT : NICKEL PLATED
  - 2-3. SHELL : NICKEL PLATED
- ELECTRICAL SPECIFICATION :
  - 3-1. Rated current : 2A
  - 3-2. Rated Voltage : 30V
  - 3-3. Water proof : IP67
- Environmental :
  - 4-1. Operation Temperature : -40°C~85°C

DRAWN	EMILY SUEN	APP'D	KU CHOU	UNIT	mm	TOLERANCE		广东科斯达电子科技有限公司 GUANG DONG KE SI DA ELECTRONIC TECHNOLOGY CO., LTD.	TITLE	防水 M12 (F) 插针 Pg9 插件式+接地			SHEET	1/1
CHK'D	KU CHOU			SCALE	1:1	.x ±0.20 .xx ±0.10 .xxx ±0.05 .xxxx ±0.03 ANGULA ±1°			PART NO.	SEE TABLE A	DWG NO.	QC7099	VERSION	